



MHT 790

MHT 790	
Lifting	
Max. capacity at 600 mm LC	9 000 kg
Max. lifting height	6.84 m
Max. outreach	3.72 m
Unladen time	
Lifting	9.2 s
Lowering	7.8 s
Extension	6.6 s
Retraction	6.1 s
Tyres	445/65 R22.5
Braking	
Service brake	Multiple-disc brake with oil bath on front and rear axles
Parking brake	Automatic negative parking brake
Engine	
	John Deere Stage IIIb (Interim Tier IV)
Type	4045PWX
Displacement	4.5 l
Power	141 HP / 104 kW
Max. torque	534 Nm / 1500 rpm
Injection	Direct
Laden drawbar pull	10905 daN
Gradeability (laden)	48%
Transmission	
	Hydrostatic
Reversing shift	electrohydraulic control
Number of gears (forward/reverse)	2/2
Max. travel speed (may vary according to applicable regulations)	30 kph
Axle	DANA
Steering mode	4 Wheel Steer - 3 steering modes 
Controls	
	JSM® Joystick multi-function - Load limiter cut off system - EN 15000 Norm
Hydraulics	
	Axial piston variable displacement pump (LS)
Load Sensing Pump	180 l/min - 270 bar
Capacities	
Hydraulic oil	151 l
Fuel	150 l
Unladen weight (with forks)	13 020 kg
Dimensions	
Overall length to carriage	5.27 m
Ground clearance	0.41 m
Overall width	2.47 m
Overall height	2.48 m
Standard forks (length x width x thickness)	1200 x 200 x 60 mm
Turning radius over tyres (V2)	4.88 m
Carriage Rotation (crowd / dump)	137°
Noise and vibration	
Noise at driving position (LpA)	79.7 dB
Environmental noise (LwA)	103 dB
Vibration to whole hand/arm	<2.5 m/s ²

MHT & MHT-X 790

Machine on tyres with forks
CDG 600 mm

**Rough Terrain Load Chart
EN 1459 Annex B**

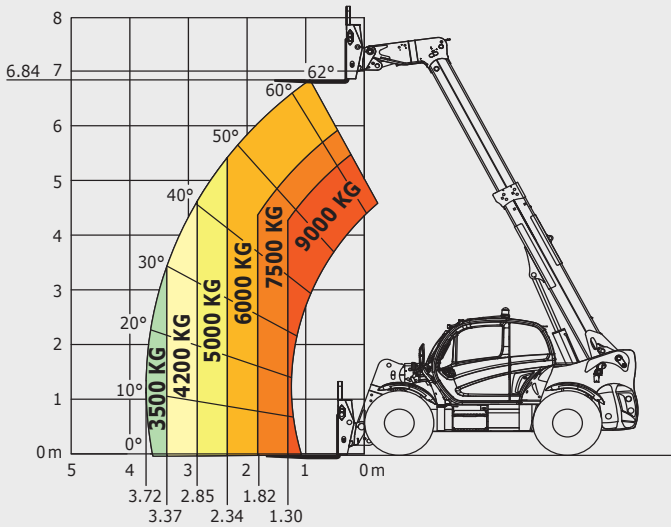

**Industrial Load Chart
EN 1459 Annex A**

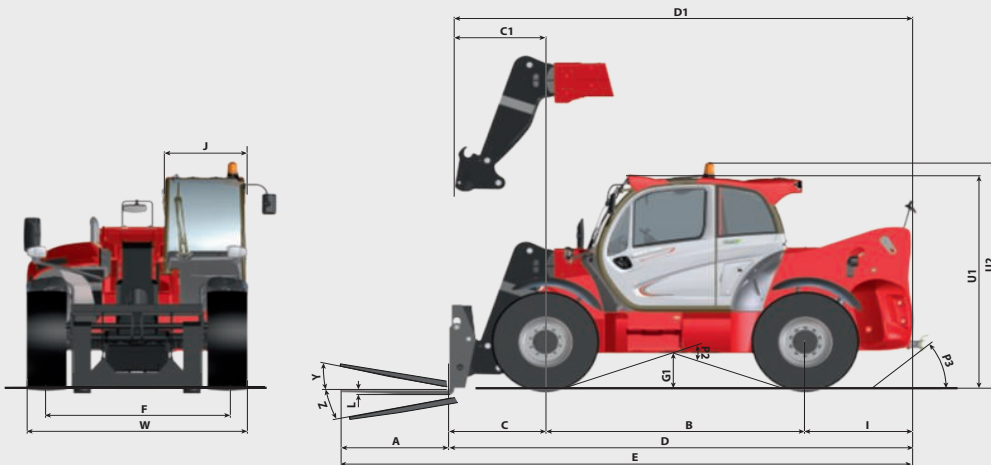
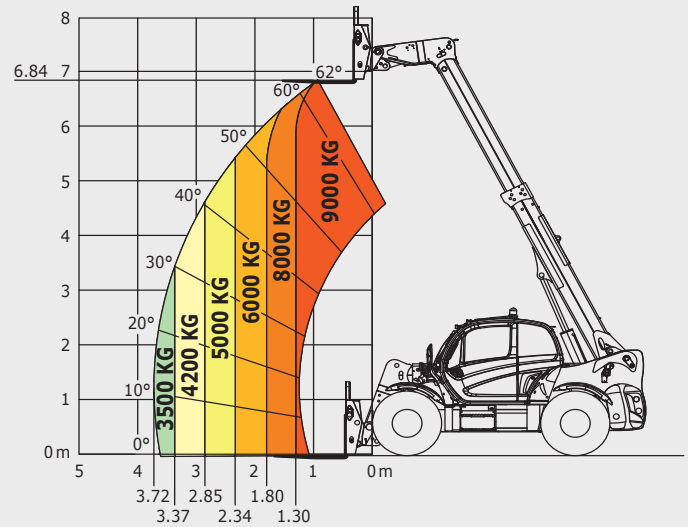

mm	MHT/MHT-X 790
A	1200
B	2870
C	1128
C1	997
D	5273
D1	5142
E	6473
F	2020
G1	409
I	1275
J	884
L	60
O	200
P2	38°
P3	26°
R	4801
S	8647
T	3481
U1	2478
U2	2657
V	5592
V1	2110
V2	4884
W	2473
Y	12°
Z	125°

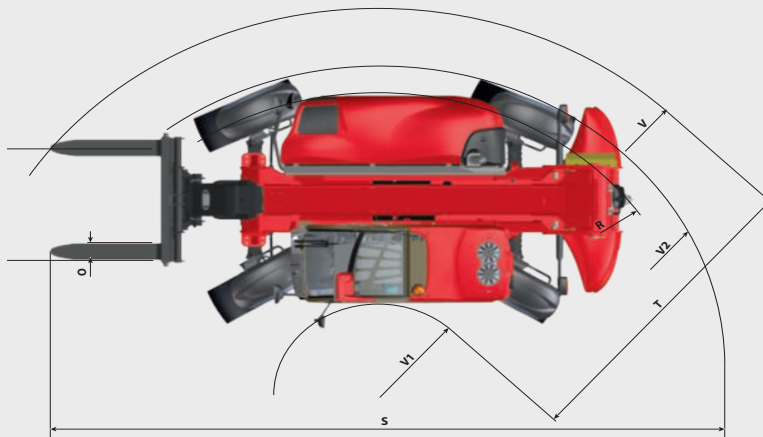

This brochure describes versions and configuration options for MANITOU products which may be fitted with different equipment. The equipment described in this brochure may be standard, optional or not available depending on version. MANITOU reserves the right to change the specifications shown and described at any time and without prior warning. The manufacturer is not liable for the specifications given. For more information, contact your MANITOU dealer. Non-contractual document. Product descriptions may differ from actual products. List of specifications is not comprehensive. The logos and visual identity of the company are the property of MANITOU and may not be used without authorisation. All rights reserved. The photos and diagrams contained in this brochure are provided for information only.

MANITOU BF SA - Limited company with board of directors - Share capital: 39,547,824 euros - 857 802 508 RCS Nantes

