



Masted  
forklift truck

**MSI 25 T**  
■ **MSI 30 T**

*Evolution*

- Standard lifting height : 3.30 m
- Nominal capacity : 2500/3500kg
- Perkins Turbo engine : 60 HP - 44.7 kw
- Hydrostatic transmission



## MSI 25 - 30

	MASTED MODEL	TYPE OF TRUCK	TOTAL LIFT ON FORKS	OVERALL MAST FOLDED	FREE LIFTING	OVERALL MAST IN USE	HEIGHT AT MAXIMUM CAPACITY	CAPACITY AT MAXIMUM HEIGHT		TILT OF THE MAST
FREE LIFTING TRIPLEX	4.70 m	MSI 25	4740	2300	1571	5469	4000	1700 - 2100	1500 - 1900	10°/12°
		MSI 30	4745	2400	1647	5500	4000	2600 - 2400	2400 - 2300	



## MSI 25 - 30 load charts Diesel and Gas

### MSI 25 T

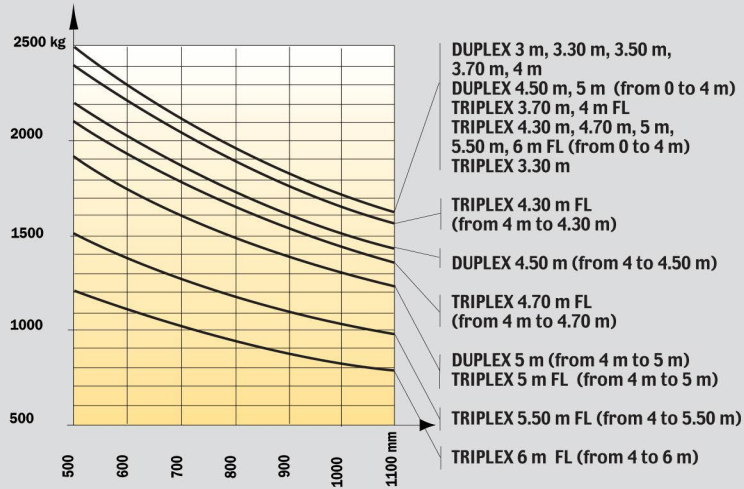

### MSI 30 T

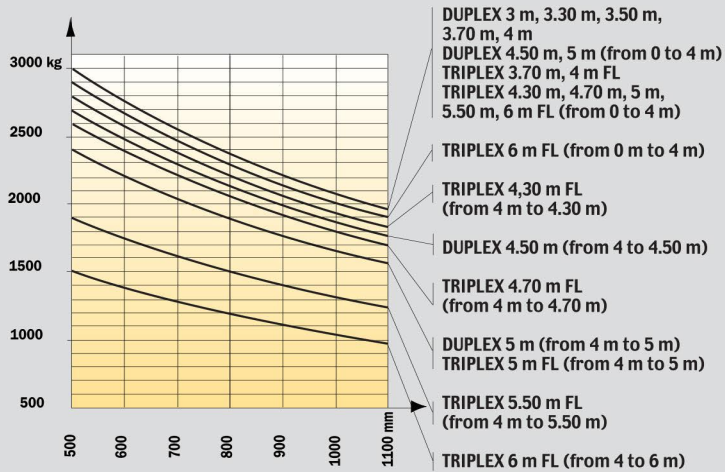

## MSI 25/30 T



**Load capacity**  
at 500 mm load centre

MSI 25 T .....2500 kg  
MSI 30 T .....3000 kg



**Standard lifting height** .....3.30 m



**Tyres**  
Front .....275/70 R 22,5  
Rear .....7.00 x 12



**Forks (mm)**  
Length .....1200  
Width x thickness .....100 x 45  
Maximum space between forks .....1260



**Hydraulic brakes**



**Perkins Turbo engine**

Typ .....404 C 22T  
Capacity .....4 cylindres 2216 cm<sup>3</sup>  
Power (ISO TR 14396) .....60 cv/44.7 kw  
Maximum torque .....190 Nm at 1800 t/mn

**Toyota LPG engine**

MSI 20 G/25 G/30 G .....Type: 4 Y  
Capacity .....4 cylindres 2237 cm<sup>3</sup>  
Power (ISO TR 14396) .....53 HP/39 kw  
Maximum torque .....162 Nm at 1800 r.p.m.  
Direct injection  
Water cooling



**HYDROSTATIC REXROTH Transmission**

Wheel drive .....2  
Electro-magnetic reversing shift  
Speeds forward/reverse .....1/1  
Maximum travel speed .....20 km/h



**Hydraulic system**

Steering pump .....125 bars/79 l/mn



**Capacities**

Cooling system .....10.5 l.  
Engine oil .....9.75 l.  
Hydrostatic transmission .....95 l.  
Fuel tank .....73.5 l.



**Weight (with forks)**

MSI 20/25/30/35 T .....4150/4530 kg

**Overall width** .....1.32 m

**Overall height (mast lowered)** .....2.30 m

**Overall length** .....4.04/4.08

**Ground clearance** .....215 mm

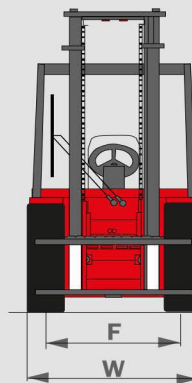
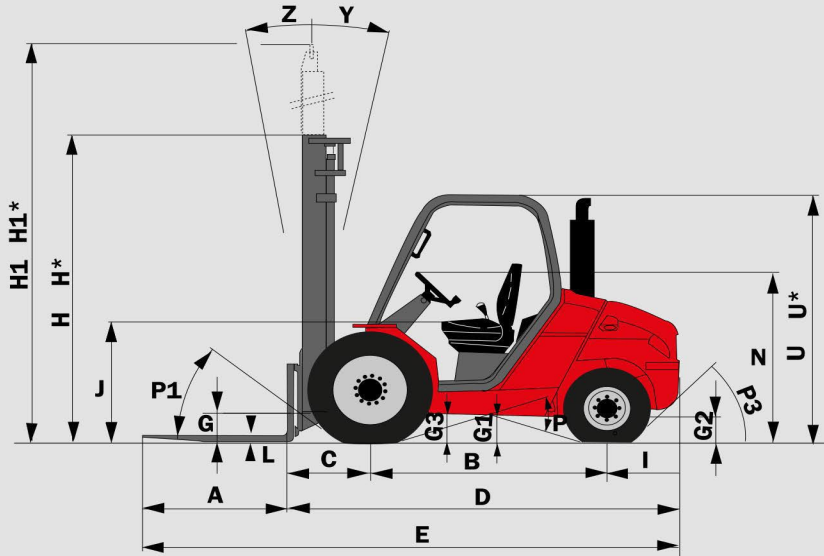

	MSI 25 T/G +BUGGIE	MSI 30 T/G +BUGGIE
A	1100	1100
B	1800	1800
C	625	630
D	2945	2980
E	4045	4080
F	1046	1046
F1	1102	1102
G	270	270
G*	240	240
G1	260	260
G1*	260	260
G2	215	215
G2*	230	230
G3	270	270
H	2300	2400
H*	1950	2050
H1	4131	4193
H1*	4470	4500
I	520	550
J	1025	1025
K	1260	1260
L	40	45
N	1450	1450
O	100	100
P1	49,5°	49,5°
P2	40,5°	40,5°
P3	44°	40°
R	2310	2310
S	2545	2580
T	4525	4560
U	2105	2105
U*	1990	1990
V	2600	2635
V1	150	150
W	1323	1323
Y	12°	12°
Z	10°	10°

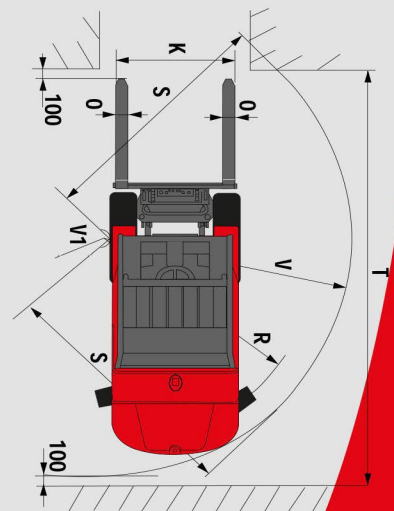

This equipment described in this leaflet may be standard, optional, or unavailable, depending on the versions. For more details, contact your MANITOU dealer.

H - H1 - R = Standard  
H\* - (Triplex 3,70 m) H1\* = Option

U\* = MSI 20/25 BUGGIE  
G\* - G1\* - G2\* = loaded



**MANITOU BF SA**

B.P. 249 - 44158 Ancenis Cedex - France  
Tel. : 33 2 40 09 10 11 / Export Department Fax : 33 2 40 09 10 97  
www.manitou.com

700314EN-B - 11/07

