

CRANE

SUSPENDED LOADS HANDLING Solutions

ADVANTAGES

- Robust solution for handling suspended loads.
- Crane fitted with 2 hooks to meet various needs of building sites and industrial applications.
- 2 forward reach possible for more flexibility in performing daily works.

TECHNICAL CHARACTERISTICS

- 1st hook: capacity: 4000 kg at 730 mm (P4000).
6000 kg at 808 mm (P6000).
- 2nd hook: capacity: 1200 kg at 2725 mm (P4000).
2000 kg at 2725 mm (P6000).
- Safety: homologated swivel self locking hooks.

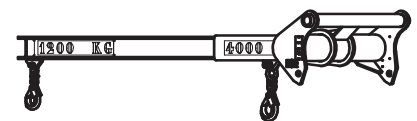
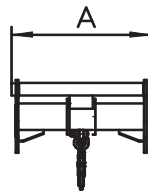
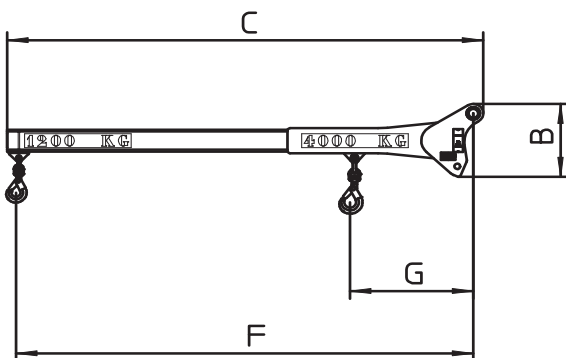

	1st hook capacity (kg)	2nd hook capacity (kg)	A	B	C	F	G	Weight (kg)
P 4000	4000	1200	830	470	2840	2725	734	210
P 6000	6000	2000	830	470	2840	2725	808	282

COMPATIBILITY*

	P 4000	P 6000
Part Number MT	653226	653227
MT 625		
MT 732	X	
MT 835	X	
MT 1030	X	
MT 1135	X	
MT 1235	X	
MT 1335	X	
MT 1440	X	
MT 1740	X	
MT 1840	X	
MRT EASY (€ 3A)	X	
MRT PRIV	X	X
Part Number MRT+	921321	921322
MRT EASY (€ 3B)	X	
MRT + PRIV	X	X

* This Attachment has been approved for the MT and MRT listed above. A load chart Machine/Attachment has been created accordingly.

This brochure describes versions and configuration options for Manitou products which may be fitted with different equipment. The equipment described in this brochure may be standard, optional or not available depending on version. Manitou reserves the right to change the specifications shown and described at any time and without prior warning. The manufacturer is not liable for the specifications given. For more information, contact your Manitou dealer. Non-contractual document. Product descriptions may differ from actual products. List of specifications is not comprehensive. The logos and visual identity of the company are the property of Manitou and may not be used without authorisation. All rights reserved. The photos and diagrams contained in this brochure are provided for information only.

MANITOU BF SA - Limited company with board of directors - Share capital: 39,547,824 euros - 857 802 508 RCS Nantes
P_EN_A_0413

