



Introduction

Instructions for crane operators

This operator's manual contains correct operational procedures plus simple servicing and inspection instructions for the UNIC crane

Make sure you read this manual and only operate the UNIC crane after you have fully understood it.

Although we take all possible measures to ensure the quality of the crane and all accompanying literature, please contact UNIC Cranes Europe Ltd if you have a query.

When making enquiries, or ordering spare parts or requesting repairs please ensure that you have the model number, specification (if applicable), serial number and date of manufacture available to speed the process.

All of this information is available on the data plate on the side of the kingpost.

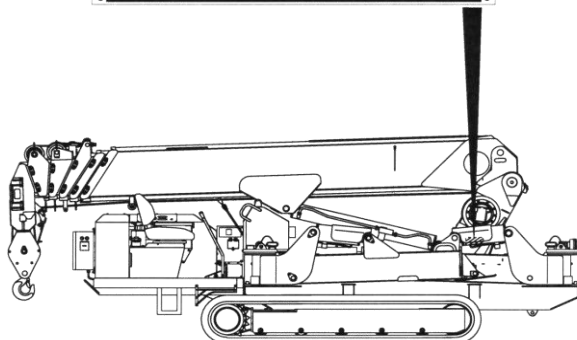
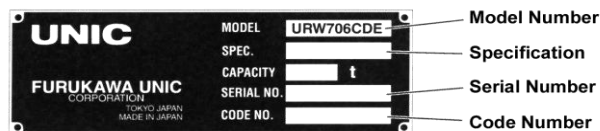
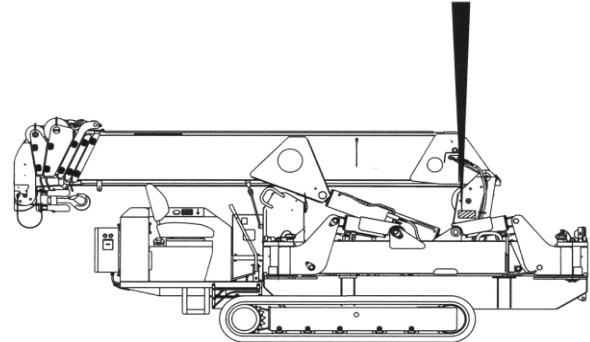
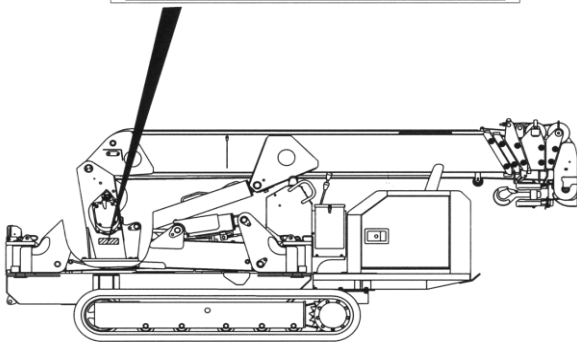
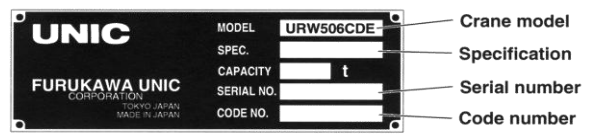
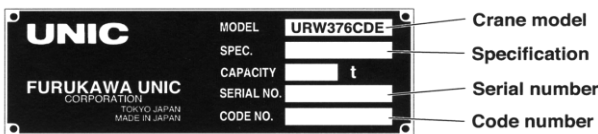





## TABLE OF CONTENTS

### SETUP OF THIS MANUAL

- 1 SAFETY INSTRUCTIONS**
  - a. *Instructions to operators*
  - b. *Loading and unloading crane*
- 2 SAFETY PRECAUTIONS FOR CARRIER OPERATIONS**
  - a. *Before operation*
  - b. *During operation*
  - c. *When loading and unloading*
  - d. *After operation*
- 3 SAFETY PRECAUTIONS FOR CRANE OPERATIONS**
  - a. *Before operation*
  - b. *During operation*
  - c. *After operation*
- 4 DESCRIPTION OF CARRIER EQUIPMENT**
- 5 DESCRIPTION OF CRANE EQUIPMENT**
- 6 INFORMATION PLATES**
  - a. *Position of information plates (stickers)*
  - b. *Information plates in detail*
- 7 DEFINITION OF TERMS**
  - a. *Outrigger extension*
  - b. *How boom sections are extended*
  - c. *Rated load*
  - d. *Rated total load*
  - e. *Hoisting loads*
  - f. *Working radius*
  - g. *Boom length*
  - h. *Boom angle*
  - i. *Lift above ground*
- 8 HOW TO REFER TO 'WORKING RANGE CHART' AND CHART OF RATED LOAD FOR EMPTY VEHICLE**
  - a. *Working range chart*
  - b. *Rated load chart*
- 9 DESCRIPTION OF CONTROLS**
  - a. *Overwinding alarm*
  - b. *Automatic overwinding stop*
  - c. *Load meter with angle indicator*
  - d. *Warning horn*
  - e. *Hook safety catch*
  - f. *Automatic stop for minimum 'wire on drum'*
- 10 CARRIER OPERATIONS**
  - a. *Designation and location of control levers*
  - b. *Before operations*
  - c. *Operation*
  - d. *Crawling operations*



- 11 CRANE OPERATIONS**
- a. *Designation and location of control levers*
  - b. *Before operations*
  - c. *Outrigger set-up procedures*
  - d. *Boom derricking operations*
  - e. *Hook operation*
  - f. *Boom telescoping*
  - g. *Slewing operations*
  - h. *Storing crane*
  - i. *Hook stowage*
  - j. *Stowing outriggers*
  - k. *How to use Extension Jib (URW 706 only)*
  - l. *How to use Searcher Hook (URW 706 only)*
- 12 INSPECTION AND MAINTENANCE OF THE CARRIER**
- a. *Pre-use inspection*
  - b. *Periodic inspection – 250 hours or 3 monthly*
  - c. *Periodic inspection – 500 hours or 6 monthly*
  - d. *Periodic inspection – 1000 hours or 12 monthly*
  - e. *Non periodic maintenance*
  - f. *Storage*
- 13 INSPECTION AND MAINTENANCE OF CRANE**
- a. *Pre-use inspection*
  - b. *Cleaning*
  - c. *Inspection of slew bearing mounting bolts*
  - d. *Wire rope replacement*
  - e. *Replacement of wearing parts*
- 14 CARRIER LUBRICATION AND WATER SUPPLY**
- a. *Precautions when carrying out lubrication and water filling*
  - b. *Recommended lubricants*
  - c. *Lubrication and water filling chart*
- 15 CRANE LUBRICATION**
- a. *Lubrication chart 376/506*
  - b. *Lubrication of reduction gears and slew gears*
  - c. *Lubrication chart of 706*
- 16 MAJOR SPECIFICATIONS**
- a. *URW376C*
    - a. *Technical Specification*
    - b. *Working Range Chart & Footprint Chart*
    - c. *Rated Load Chart*
  - b. *URW506C*
    - a. *Technical Specification*
    - b. *Working Range Chart & Footprint Chart*
    - c. *Rated Load Chart*
  - c. *URW706C*
    - a. *Technical Specification*
    - b. *Working Range Chart & Footprint Chart*
    - c. *Rated Load Chart*
    - d. *Rated Load Charts for Extension Jib and Searcher Hook*
  - d. *Additional information for electric pack versions*
  - e. *Emergency lowering equipment (where fitted)*
  - f. *How to use Searcher Hook (URW 376 / 506)*





**17 DISMANTLING PROCEDURES – URW 506C & 706**

- a. *Sub-assembly weights*
- b. *Dismantling procedures*
- c. *Re-assembly procedures*
- d. *Components to be ordered prior to disassembly*

**18 ADDITIONAL EQUIPMENT**

- a. *Safe Load Indicator*
  - i. *Calibration Handbook*
  - ii. *Operations Handbook*
- b. *Wireless Remote Control*

**19 CERTIFICATION**

- a. *EC Declaration of Conformity*
- b. *Certificate of Test and Examination of the Hook*
- c. *Certificate of Strength of Wire Rope*
- d. *Report of Thorough Examination*
- e. *Four Yearly Test Report*





## 1 **SAFETY INSTRUCTIONS**

### a. **Instructions to operators**

- The UNIC URW 376C / 506 / 706C is designed in accordance with all relevant European safety regulations. However, operating errors and misuse will result in hazards:
  - i. to the life of the operator and others;
  - ii. to the lifter and materials of the company and others;
  - iii. to the correct and efficient operation of the device.
- Only personnel who have the correct authorisation issued by an accredited training provider may operate this machine
- All persons involved with the set-up, operation and maintenance of the machine must read and observe the following instructions. The personal safety of yourselves and others that may encroach upon your operation is at stake.
- Always observe prohibition and hazard signs as explained in this manual. Failure to do so could lead to serious injury or death to the operator or others. Additionally damage to the crane or surrounding area.
- Always make sure that this manual is available to the operator
- Unauthorised alteration to the structure or operational controls of the device is prohibited for safety reasons. If alteration of the crane is required contact UNIC Cranes Europe Ltd
- Intended use also requires observance of the operating manual and adherence to the conditions for inspection and maintenance.
- Only operate the UNIC 376C / 506 / 706C under the correct environmental conditions, to do otherwise jeopardises health and safety, and will invalidate the Report of Thorough Examination and any warranties still in force.
- The crane must only be operated within the limits of the Working Range Chart and Rated Load Chart.

Explanation of symbols used in this manual



**Prohibition: DO NOT carry out**



**NO SMOKING or naked flames**



**General Hazard: Be very cautious**



**Operational notes**



**Highly Flammable**



**Toxic Substances**

**b. Loading and Unloading**

When loading and offloading with a crane, only use the lifting points shown below. Use of other points for lifting may result in failure of the suspension point or lifting gear. This may cause serious or fatal injury to personnel and serious damage to the crane.

Always ensure that the lifting points are fitted with shackles of the correct size and capacity. Use of the wrong type will result in damage to, and maybe failure of, the lifting point or lifting accessory.

Loading and off-loading operations must only be carried out by an operator authorised to use the type of equipment used. Loading/unloading operations must always be supervised by a competent person.

Where a ramp is used, that is not an integral part of the transport vehicle, it must be of sufficient strength to bear the weight of the crane. It must be at least four times as long as the height of the truck platform. For further details read the Loading and Off Loading Procedures information plate.

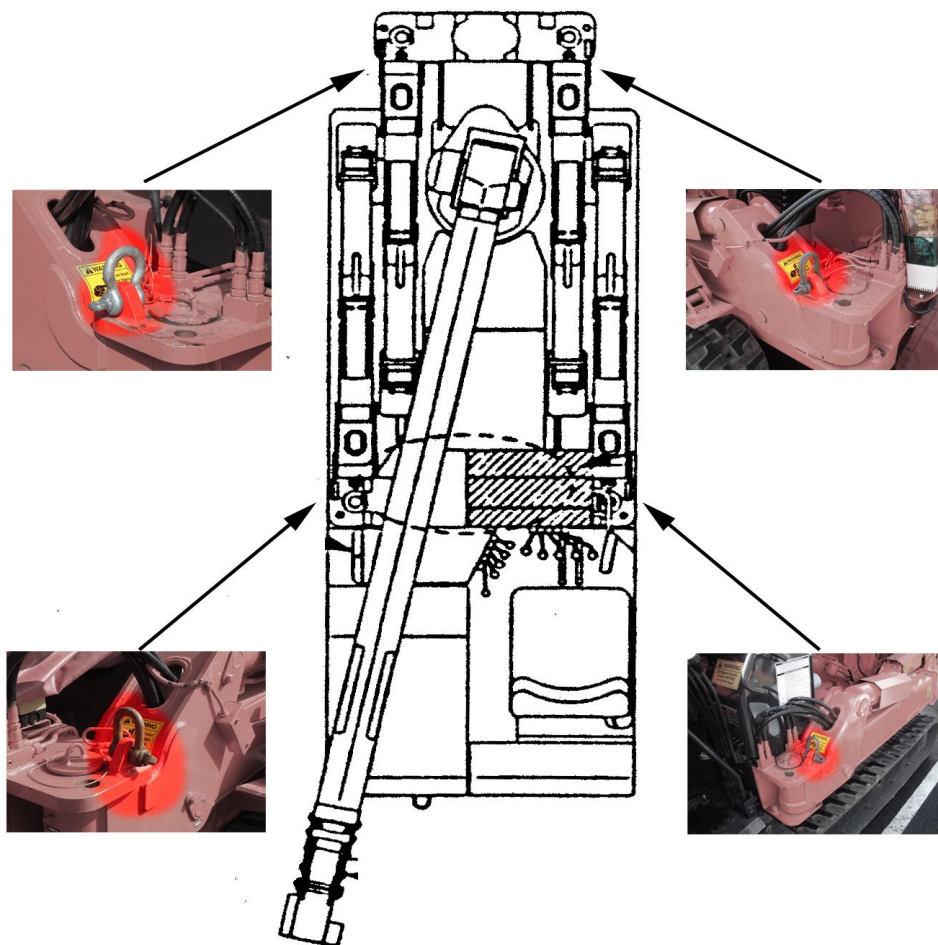



## 2 **SAFETY PRECAUTIONS FOR CARRIER OPERATIONS**

### a. **Before operation**

- Always wear correct PPE for the task. Do not wear loose or torn clothing as this may cause a hazard with rotating machinery or wire rope. If wearing loose jewellery or hair is worn long, take additional precautions to ensure that it cannot come into contact with moving machine parts.
- Carry out pre-use inspection. If a defect is found, do not carry on the operation until it has been rectified.
- Ensure all safety covers are correctly fitted. Failure to do so may leave moving machinery exposed.
- The engine must be stopped with the ignition turned off before re-fuelling or lubrication can commence. Remove all naked flame and incandescent heat sources from area.
- Do not operate the machine inside buildings without adequate ventilation. To do so will cause carbon monoxide poisoning and eventual death.
- Press the 'crane-crawl' interlock pedal with your left foot. This allows the driving control levers to move and electronically engages the crawl function. No crane operations can function with the interlock in this position.

### b. **During operation**

- Due to the small size of the carrier, the overall crane has a high centre of gravity. Particular care must be taken when crossing uneven ground, otherwise the crane may turn over.
- When crawling, the outriggers must be stowed and locked.
- The crane must not be moved with a load suspended on the hook or without the hook being stowed correctly. The boom must be fully retracted and stowed correctly
- When travelling over rough ground ensure that the crane is being driven slowly.
- Do not run the crane over bumpy area, lying rocks with sharp edges, rough solid rock, small broken stones, edges of steel plate, steel bars for reinforcement, scrap metals, and waste materials and on a road such as in riverside where covered with many stones which may remarkably shorten service of rubber crawler.
- Where there are bumps or depressions, ensure that the crane is driven directly at them to minimise any stress to the carrier chassis caused by twisting.
- Make sure a board is used where the crane has to go over a vertical rise of more than 150mm.



- When driving on a slope ensure that crane is only driven in 1<sup>st</sup> gear. Do not abruptly change course on a slope. Avoid crossing a slope. When travelling straight up and down a slope, always stand up to ensure you have a better view of the approaching ground.
- When parking on a slope ensure that the tracks are adequately chocked.
- Do not attempt a slope of greater than 10 degrees.
- Do not park the crane on areas of dry grass, etc. The hot exhaust may cause a fire.
- Do not crawl with anything stowed on the vehicle. This may cause a shift in the centre of gravity and cause the vehicle to turn over.
- Do not use the hook holder on the rear of the vehicle for towing. It may break off.

**c. Loading and unloading**

- Use non-slip boards of sufficient strength, width and length
- Drive the vehicle straight up and down, do not change direction
- Stop the engine, apply parking brake and chock the tracks to secure the vehicle

**d. After operation**

- Return the crawler levers to the neutral position and allow the engine to idle.
- Remove your foot from the 'crane-crawl' interlock pedal. This locks the driving control levers and electronically disengages the crawl function. The vehicle can now carry out only crane functions.
- Stop the engine and clean the crane. Pay particular attention to electrical areas such as wiring or battery as this could cause a short, leading to a fire. Likewise ensure all hot running areas of the engine, including the silencer, are thoroughly cleaned.
- Either park the crane in a garage or use the cover to protect it. If fitting the cover ensure all hot parts of the crane have cooled sufficiently. Otherwise it may lead to a fire.
- Remove the ignition key and store it safely. If being left for long periods of time, disconnect the negative lead from the battery.



### **3 SAFETY PRECAUTIONS FOR CRANE OPERATION**

#### **a. Before operation**

- Carry out pre-use inspection on carrier, crane and any lifting accessories you may be using.
- Ensure your foot is not on the 'crane-crawl' interlock pedal.
- Ensure that all safety devices are functioning properly.
- Ensure that adequate distance is maintained between the crane and any high voltage electricity cables. Refer to BS7121:Part 1:1989 and HSE Guidance Note GS6.
- Do not operate crane when wind speed exceeds 10m/sec (36 kph or 22 mph).
- Do not operate crane when there is lightning in the immediate vicinity of the operation.
- Ensure that the ambient lighting is adequate to carry out the task safely. For guidance on adequate lighting refer to the HSE document HS(G)38
- Ensure that the work area is adequately cordoned and signed to prevent unauthorised persons entering.
- Ensure that the area where the outriggers are to be set is level, uniform and firm. This may require the use of dunnage or road plates.
- Using the outriggers, lift the crane approximately 50mm from the floor. Ensure the carrier bed is level. If not use the outriggers to level it.
- In normal operation ensure the outriggers are fully extended.

#### **b. During Operation**

- Where there is a possibility that the load may traverse over the operator position the operator must ALWAYS use the remote control to position themselves a safe distance OUTSIDE of the arc of traverse. Where possible, the remote control is always the preferred method of operation.
- Pay attention to hook overwind. Remember that the hook is wound up during boom extension and if the hook strikes the boom it may cause damage to the wire rope or sheaves. This may lead to loss of the load.
- Operate the controls slowly and smoothly
- Slew the crane at slow speed. High speed slewing causes the load to swing out, increasing the working radius which may lead to instability.
- Adjust the engine speed according to the load and manoeuvre. Too low a speed can cause the load to swing due to engine pulsation.
- Never operate the crane in an overload condition, to do so may lead to serious injury or death.



- Never attempt to pull a load using the crane, this can lead to overturning or serious damage to the crane structure.
- Always perform a check lift. Lift the load approximately 50mm from the floor and check the stability of the load and the correct positioning of the lifting attachments before proceeding with the lifting operation.
- When lowering a load always stop approximately 100mm from the floor and lower the remaining distance slowly.
- Never leave a suspended load unattended.
- Never ride the hook or the load.
- Never stand underneath a suspended load.
- Do not allow ropes to go slack when lowering a load to the ground, or when retracting the jib as it will cause the ropes to unwind from the drum. This will cause irregular winding of the rope on take-up, dramatically shortening the life of the rope. If unwinding does occur, apply tension to the rope manually and take-up slowly, ensuring the rope feeds on evenly until the load or hook is clear of the floor.
- Ensure that there are a minimum of three turns of rope left on the drum at all times. This may occur where the hook is lowered below floor level, e.g. from the roof or into an underground shaft.
- Stop crane operations when the hydraulic oil temperature exceeds 80°C. Excessive temperature may cause gasket or seal failure allowing scalding oil to be ejected at very high pressure.

c. **After Operation**

- Ensure that the boom, outriggers and hook have been correctly stowed prior to crawling.
- Do not carry out any maintenance or repairs on the machine until the hydraulic and gear oil has sufficiently cooled.





**This page is intentionally blank  
to allow the following pages to  
be viewed as facing pages**



#### 4 **DESCRIPTION OF CARRIER EQUIPMENT**

1. **Rubber Track.** Cored bar and steel fabric cords are integrally moulded into the rubber
2. **Wheel Sprocket.** Transmits the drive to the track
3. **Idle Roller.** Supplies the correct tension to the track
4. **Truck Roller.** Supports the weight of the crane and rolls on the rubber track
5. **Crawling Motor.** Is a hydraulic motor with reduction gearing built inside the wheel sprocket housing
6. **Crawling Lever.** Allows the operator to change the direction of the machine
7. **Accelerator Pedal.** Controls engine speed
8. **Drivers Seat**
9. **Fuel Tank.** Diesel only
10. **Hydraulic Oil Tank.** This reservoir supplies both the carrier and the crane
11. **Starter Switch.**
12. **Hour Meter.** This indicates total cumulative engine running time
13. **Crane-Crawl Interlock Pedal.** This prevents the carrier from travelling while operating the crane, or the crane from operating when the carrier is crawling. This also prevents the vehicle being operated or driven without the driver seated or stood in the correct operating position.
14. **Crawl Speed Selector Button.** This allows the carrier to crawl faster when it is being depressed. This applies only when travelling straight
15. **Warning Lamp.** This gives warnings of faults
16. **Emergency Stop Switch.** Activation of this switch stops the engine and all crane function including travelling.
17. **Pedal.** This is used to switch the function of the crane-crawl interlock
18. **Headlight**

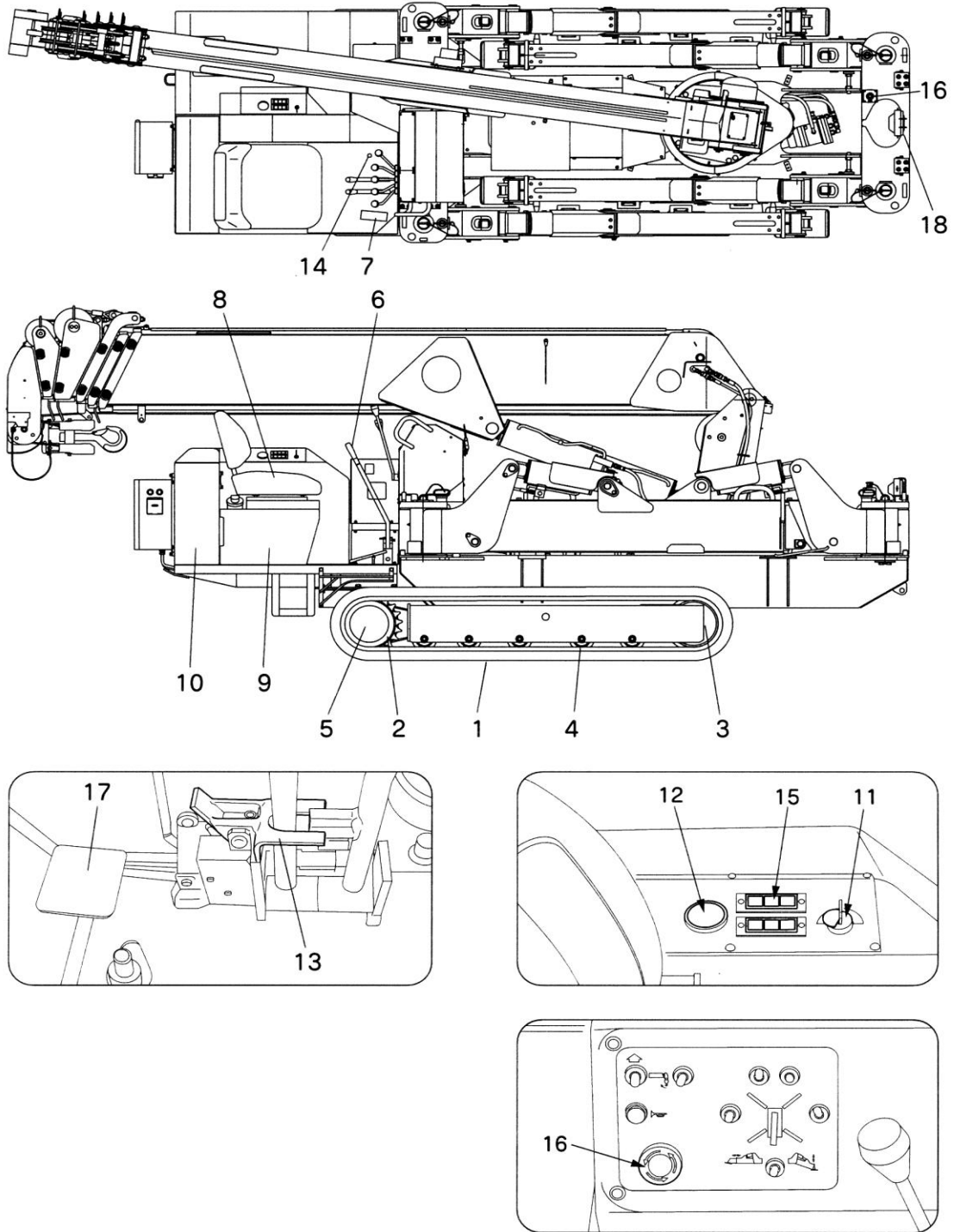



**Intentionally Blank**



## 5 **DESCRIPTION OF CRANE EQUIPMENT**

- 1 **Boom or Jib.** Extends and retracts by hydraulic power
- 2 **Column or Kingpost.** Vertically mounted member on which boom, winch and derrick cylinders are mounted. This can be slewed 360 degrees
- 3 **Frame.** This is fixed to the carrier and supports the column and outriggers
- 4 **Hoist Winch.** For rotating the wire drum
- 5 **Slewing Device.** Rotates the column via hydraulic motor
- 6 **Derricking Cylinder.** Raises and lowers the boom
- 7 **Telescoping Cylinder.** Extends and retracts the boom
- 8 **Outrigger.** This supports and stabilises the crane during operation
- 9 **Crane Operating Levers.** Respective levers operate crane functions, such as raising and lowering boom, telescoping and slewing boom, raising and lowering load
- 10 **Outrigger Control Levers.** Respective levers control raising/lowering and extending/retracting outriggers
- 11 **Hook.**
- 12 **Overwinding Alarm.** Alerts the operator that the hook is approaching the top of the boom and they should stop hoisting otherwise damage and/or loss of the load could occur
- 13 **Wire Rope**
- 14 **Load Indicator.** This directly shows an approximation of the rated load value corresponding to the boom extension and raised angle
- 15 **Automatic Stop.** This device stops the drum automatically when the wire rope is approaching 3 turns left on the drum.
- 16 **Level.** This is for checking the horizontal plane of the vehicle.
- 17 **Voice Switch.** This toggles ON and OFF the voice warning system
- 18 **Operation Mode Switch.** This selects between crane mode and outrigger mode
- 19 **Outrigger Vertical/Horizontal Selector.** This switches selection between vertical cylinder and inner box
- 20 **Outrigger Control Switch.** This selects which outriggers are to be extended/retracted
- 21 **Hook Storing Switch**



- 22 **Horn Switch**
- 23 **Emergency Stop Switch** Activation of this switch stops the engine and all crane function including travelling
- 24 **Automatic Stop for Overwind Reset Switch.** When the crane stops due to a fault with the overwind alarm, this switch will reset the function
- 25 **Headlight Switch**
- 26 **Boom Storage Monitor Lamp.** This shows when the boom has been stored correctly. The outriggers cannot be operated unless this lamp is lit.
- 27 **Outrigger Monitor Lamp.** When the outriggers have been moved from their stored position to the operation position, the set pins will activate will illuminate the lamps when inserted fully. Outriggers cannot be operated unless all set pins are correctly inserted and all four lamps are lit.
- 28 **Mode Selector Switch.** This switch selects between radio remote control and manual control

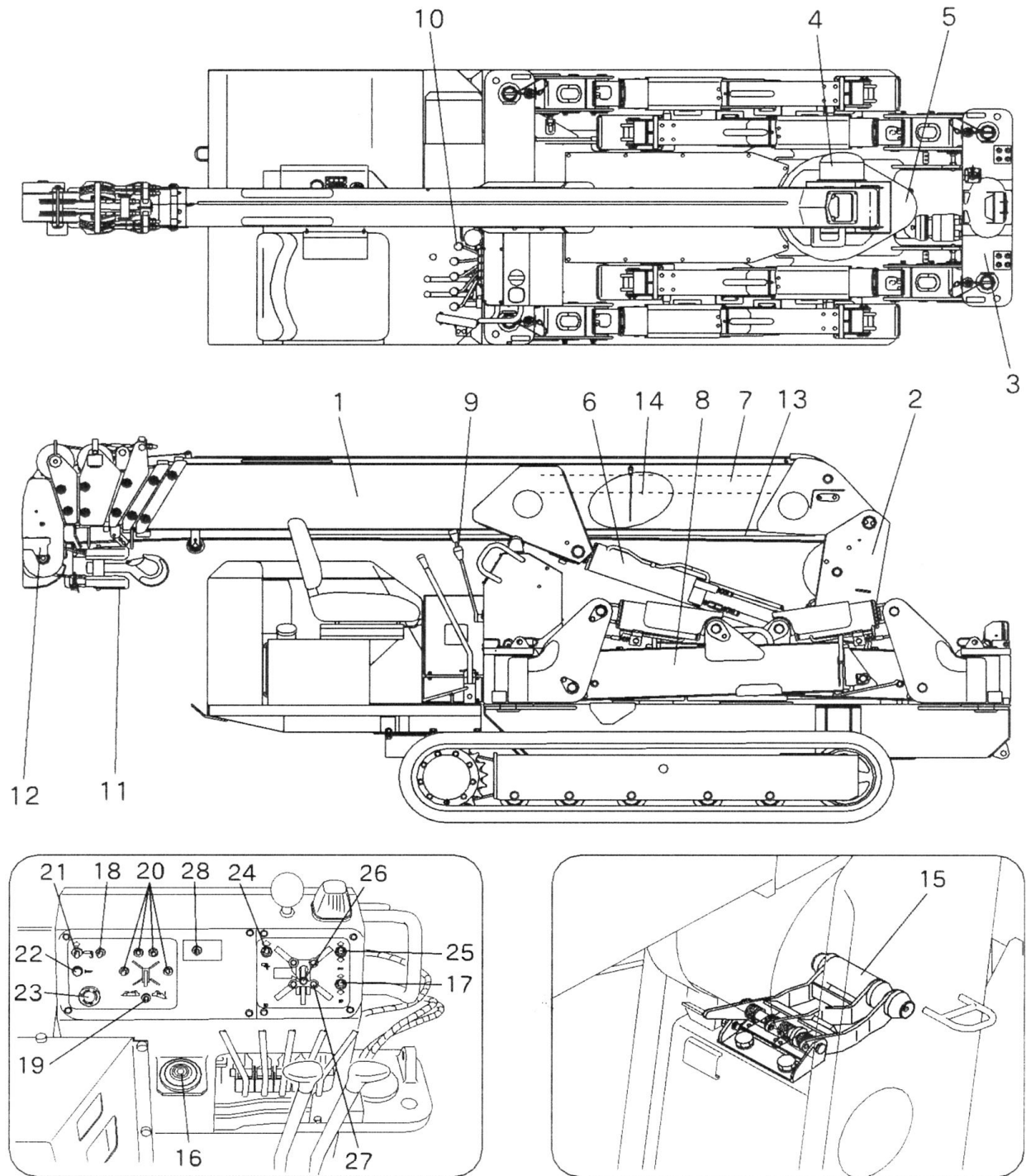



**Intentionally Blank**





**6 INFORMATION PLATES**

**a. Position of information plates**

The machine is provided with information plates (stickers) indicating hazards (framed in boxes) and specifications as shown below. In addition there are plates showing control and switch functions, and instructions for lubrication

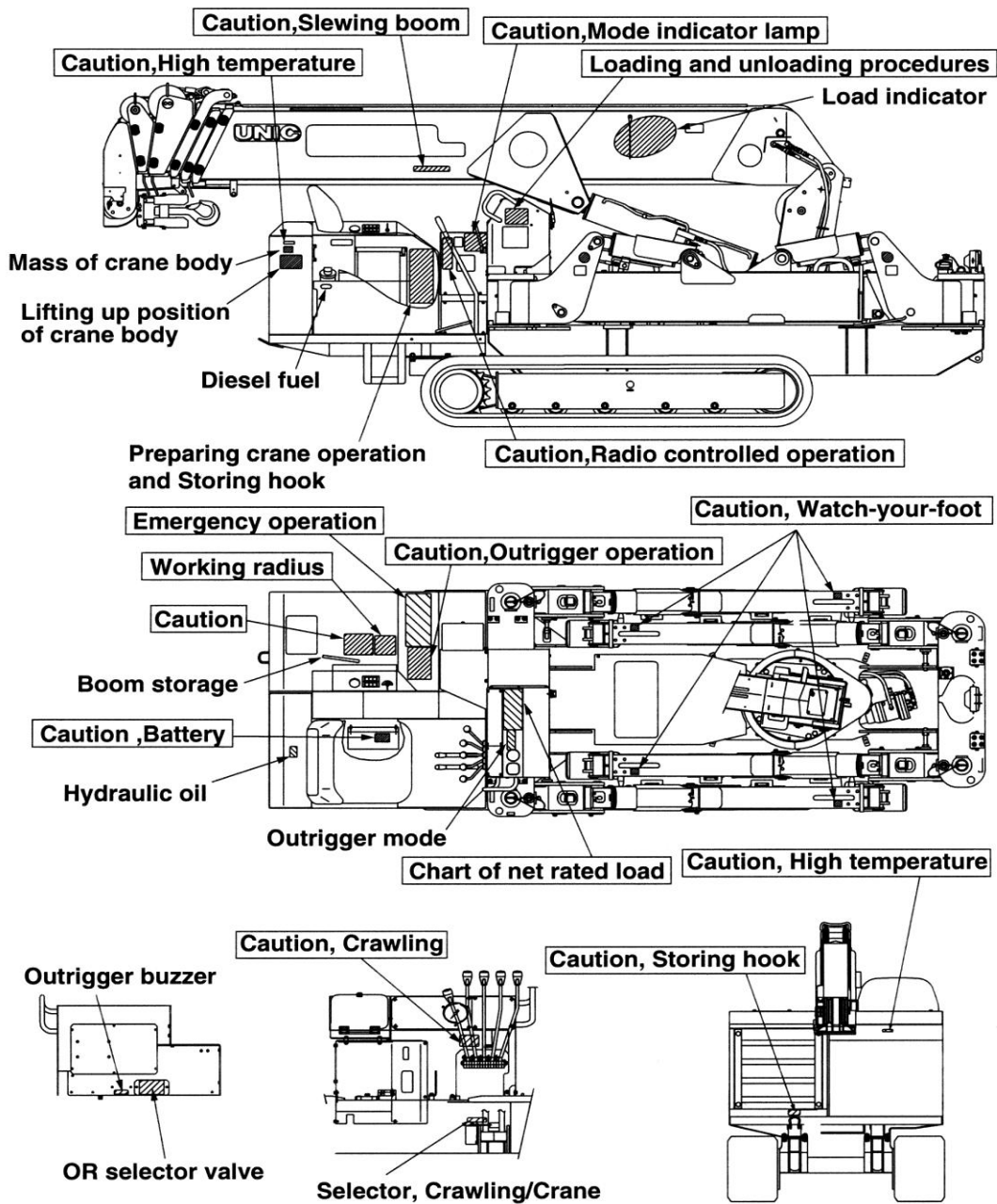



**b. Index of information plates**

Label	English	Model	Qty per crane
UCE 01.02	Diesel	376 / 506 / 706	1
UCE 01.03	Beware feet	All	4
UCE 01.04	Beware trapping in rope	All	2
UCE 01.05	Emergency stop	All	2
UCE 01.06	Beware rotating parts	All	1
UCE 01.07	Flammable	All	1
UCE 01.08	High pressure hydraulic oil	All	2
UCE 01.09	Adequate ventilation	All	1
UCE 01.10	Beware trapping in belts	All	1
UCE 01.11	Do not open hot radiator	376 / 506 / 706	1
UCE 01.12	Striking hazard	All	4
UCE 02.15	376 CD Total weight	376 CD	2
UCE 02.16	376 CDM Total weight	376 CDM	2
UCE 02.17	506 CD Total weight	506 CD	2
UCE 02.18	506 CDM Total weight	506 CDM	2
UCE 01.19	Battery	All	1
UCE 01.20	Corrosive	All	1
UCE 01.21	Trapping hazard	All	4
UCE 01.22	General warning	All	4
UCE 01.23	Electrical hazard	All	1
UCE 01.24	Hot surface	All	1
UCE 01.26	Sit at top	376 / 506 / 706	1
UCE 01.27	Maximum gradeability	All	1
UCE 01.28	Lifting point	All	4
UCE 01.29	Read manual	All	1
UCE 01.30	Read service manual	All	1
UCE 01.31	Do not put fingers in holes	All	4
UCE 01.34	No hands	All	1
UCE 01.35	Smoking prohibited	All	1
UCE 01.38d	Noise Level	376	1
UCE 01.38e	Noise Level	506	1
UCE 01.43	Mode Indicator Lamp	All	1
UCE 01.44	Loading/Offloading	All	1
UCE 01.45	Trained personnel	All	1
UCE 01.47	Characteristics of performance	All	1
UCE 01.48	Radio Remote Control	All	1
UCE 02.53	376 Rated load chart	376	1
UCE 02.54	506 Rated load chart	506	1
UCE 02.66	Working Range	706	1
UCE 02.68	Net Rated Loads	706	1
UCE 02.55	376 Outrigger dimensions	376	1
UCE 02.56	506 Outrigger dimensions	506	1
UCE 02.69	Caution Outrigger Operation	706	1
UCE 02.59	Outrigger Control Switch	376 / 506 / 706	1
UCE 02.60	Outrigger Monitor	376 / 506 / 706	1
UCE 02.61	Outrigger Mode Indicator Light	376 / 506 / 706	1
UCE 02.62	Mode Indicator	376 / 506 / 706	1
UCE 02.63	Emergency Outrigger Operation	376 / 506 / 706	1
UCE 02.64	Position of Outrigger Valves	376 / 506 / 706	1
UCE 02.65	Preparation for Travel & Operation	376 / 506 / 706	1
UCE 02.70	Working Range	706	1
UCE 02.71	Net Rated Loads	706	1



09HT 37030	Net Rated Load Chart for Searcher Hook	506	1
09HA 37080	Net Rated Load Chart for Searcher Hook	376	1
09EM 37090	Angle Position for Searcher Hook	376 / 506	1
09EM 37110	Angle Position for Searcher Hook	376 / 506	1
09HA 37070	Lifting Capacity	376 / 506	1



**UCE 01.02**



**UCE 01.03**



**UCE 01.04**



**UCE 01.05**



**UCE 01.06**



**UCE 01.07**



**UCE 01.08**



**UCE 01.09**



**UCE 01.10**



**UCE 01.11**



**UCE 01.12**



**UCE 02.15**



**UCE 02.16**



**UCE 02.17**



**UCE 02.18**



**UCE 01.19**



**UCE 01.20**



**UCE 01.21**



**UCE 01.22**



**UCE 01.23**



UCE 01.24



UCE 01.26



UCE 01.27



UCE 01.28



UCE 01.29



UCE 01.30



UCE 01.31



UCE 01.34



UCE 01.35



UCE 01.38d



UCE 01.38e





**CAUTION MODE INDICATOR LAMP**

INDICATOR (LIT)	OPERATIONAL MODE (STATUS)	REMOTE CONTROL SELECTOR	POSSIBLE OPERATIONS
00	CRANE STATUS	SELECTOR ON	MANUAL AND REMOTE
01		SELECTOR OFF	MANUAL ONLY
04	OUTRIGGER REMOTE CONTROL MODE	SELECTOR ON	MANUAL AND REMOTE
05		SELECTOR OFF	MANUAL ONLY
10	OVERWINDING	—	—
13	HOOK STORAGE	—	—
14	CANCELLATION OF AUTOMATIC STOP	—	—
15	AUTOMATIC STOP	—	—
0F	DRIVE MODE	—	—

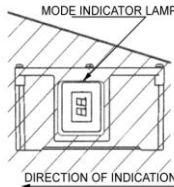

- The table shows the main indications. For further information see the remote control manual
- The remote control selector switch opposite the Mode Indicator Lamp allows the remote control operation to be turned ON or OFF
- When remote control is ON all remote control operations may be performed
- When remote control is OFF no remote control operations may be performed
- Flashing of the mode indicator lamp shows incorrect operation or malfunction of the equipment. See the remote control manual for troubleshooting advice

UCE.01.43.GB.095/295

**UCE 01.43 ALL**

**LOADING AND UNLOADING PROCEDURES UNIC**

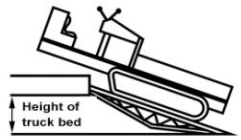

Minimum length of loading ramp must be 4 times as long as the height of the truck bed

**Loading ramp requirements**

- **Material:** Metal board with anti-slip surface
- **Strength:** Must be capable of supporting gross weight of crane on one board

1. When loading ramps are used always ensure the vehicle is stable.
2. Install the loading ramps securely to ensure they will not move during use
3. Stop the loading vehicle engine and apply the parking brake
4. Align the crane tracks with the loading ramp(s)
5. Always use a banksman to direct the crane
6. Move the crane up or down the loading ramp at the lowest possible speed
7. Always ensure the driver/operator is seated or stood at the higher end of the crane
8. Do not make any change of direction whilst travelling on the loading ramp unless specifically instructed by the banksman
9. Be especially careful when the middle of the tracks reach the top of the loading ramp as the weight will suddenly move
10. Secure the crane on the vehicle bed by chocking the tracks front and rear and tying down with ratchet straps or chains and tensioners

UCE.01.44.GB ALL

**UCE 01.44 ALL**

ONLY  
to be operated  
by trained personnel

---

! WARNING

---

Outriggers must be in  
place BEFORE  
operations begin

UCE.01.45.GB ALL

**UCE 01.45 ALL**

CHARACTERISTICS OF PERFORMANCE

1. With the same working radius, lifting capacity will still vary depending on the stage of boom extension in use. Even slight changes in the working radius can have large effects on the capacity
2. Lifting capacity of the crane reduces as the working radius increases
3. Lifting capacity of the crane varies according to the outrigger extension
4. Stability of the crane varies according to the boom direction, forward, rearwards or lateral

GENERAL RULES FOR USING CRANE

- (1) Before work
  1. Make sure you have read and understood the manual before use
  2. Always carry out the pre-use inspection in accordance with legislation
  3. Where possible always set the outriggers to their maximum extension
  4. Ensure the outrigger locking pins are correctly inserted and secured before extending outrigger
  5. Ensure the outriggers are setup on firm and level ground and that all the outriggers are in contact with the ground
  6. Use the outriggers to raise the rubber tracks 50mm off the ground
  7. Use the outriggers to level the carrier
  8. Ensure the overhoist alarm works (voice warning and operation stops)
- (2) During work
  1. Stable and safe lifting depends on the outrigger settings and ground conditions. A lift must never be carried out if one or more outriggers are off the ground
  2. Always ensure the engine is run at the lowest possible speed to carry out a given operation
  3. Operate the controls slowly and smoothly to minimise any swaying of the load. Loads that swing can alter the stability of the crane leading to extremely dangerous situations
  4. Do not use the crane to drag loads, either laterally or longitudinally, nor should you lift a load at an angle, this is extremely dangerous and could damage the crane
  5. Do not allow anyone to stand or walk under a boom when a load is attached. Never leave suspended loads unattended
- (3) During travelling
  1. Boom, hook and outriggers should be stowed securely prior to travelling
  2. When turning or travelling over rough ground, use the slowest speed
  3. When parking always place chocks under the tracks
  4. When travelling uphill or up boards/ramps always ensure the driver/operator is seated or stood at the highest end of the vehicle
- (4) Inspection
  1. All inspections must be carried out in accordance with current legislation. Failure to carry out periodic servicing as specified in the maintenance manual will invalidate any warranty in force
  2. Defects must be rectified before crane is next used
  3. The replacement or replenishment of any consumables must be carried out in accordance with the standards in the maintenance manual

01.47.GB ALL

**UCE 01.47 ALL**



**CAUTION REMOTE CONTROL OPERATION**

- For approximately 2 seconds after the key is switched ON the system is analysed. DO NOT operate the crane during this period. If the crane IS operated during system analysis a voice announces "Service Remote Control". If this happens turn the key ON again
- When the emergency stop switch on the switch panel is activated, all the crane movements stop immediately
- If, after the key is turned ON, the crane does not operate in spite of the voice announcing "Remote Control Ready", the emergency stop switch may still be activated. Turn the emergency stop switch to RESET
- Take care when performing hook storage with the switch panel as the manual operating lever also moves
- Take care when operating with the remote control as the manual levers move in conjunction with the operation of the relevant remote selection

UCE 01.48a\_GB 095/295

**UCE 01.48**

**ALL**

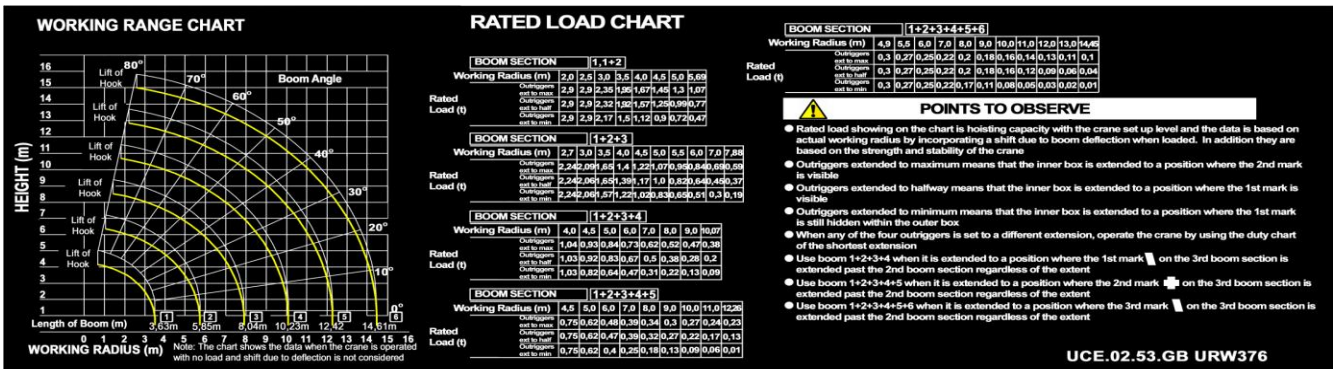

**UCE 02.53**

**URW 376**

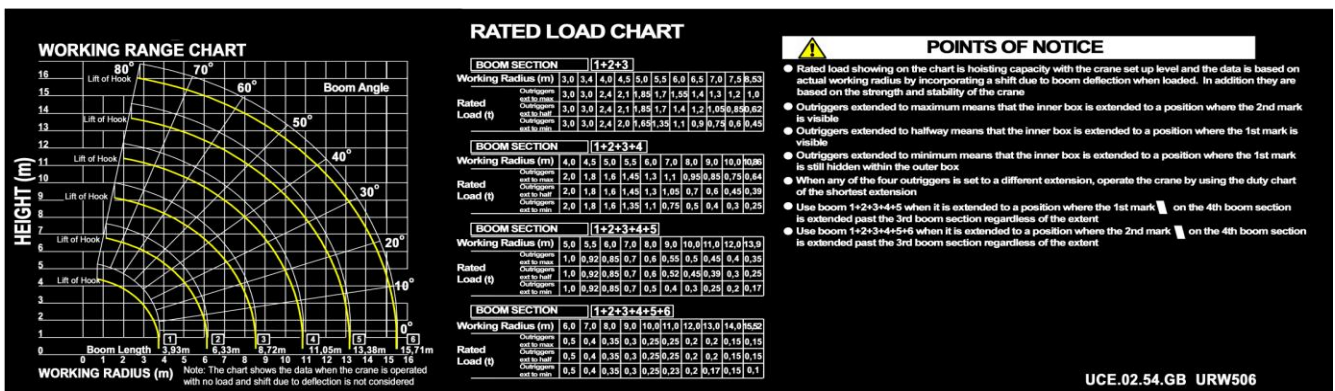

**UCE 02.54**

**URW 506**



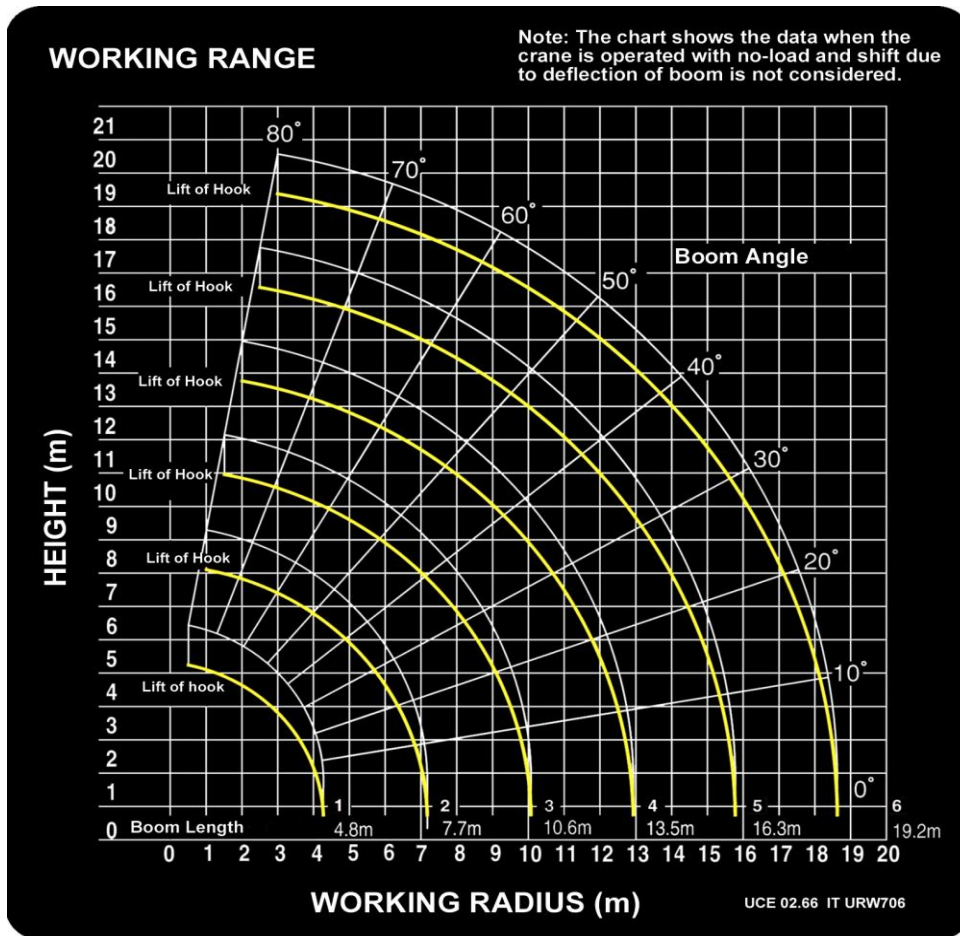

**UCE 02.66      URW 706**

**NET RATED LOADS**

<b>BOOM SECTION 1</b>					
WORKING RADIUS(m)					
	2.7	3.0	3.5	4.0	4.3
NET RATED LOAD(t)	6.0	6.0	5.45	4.85	3.95
OUTRIGGERS EXTENDED TO	MAXIMUM	6.0	6.0	5.45	4.85
	HALFWAY	6.0	6.0	5.45	4.85
	MINIMUM	6.0	6.0	5.45	4.55

<b>BOOM SECTION 1+2</b>								
WORKING RADIUS(m)								
	2.0	3.0	3.5	4.0	5.0	6.0	7.0	7.2
NET RATED LOAD(t)	6.0	6.0	5.35	4.75	3.75	2.95	2.25	2.0
OUTRIGGERS EXTENDED TO	MAXIMUM	6.0	6.0	5.35	4.75	3.75	2.45	1.7
	HALFWAY	6.0	6.0	5.35	4.65	2.55	1.65	1.15
	MINIMUM	6.0	6.0	5.35	4.65	2.55	1.65	1.05

<b>BOOM SECTION 1+2+3</b>									
WORKING RADIUS(m)									
	2.7	4.0	5.0	6.0	7.0	8.0	9.0	10.0	10.1
NET RATED LOAD(t)	4.55	4.55	3.65	2.95	2.4	1.8	1.35	0.95	0.95
OUTRIGGERS EXTENDED TO	MAXIMUM	4.55	4.55	3.65	2.55	1.75	1.3	0.95	0.7
	HALFWAY	4.55	4.55	3.65	2.55	1.75	1.3	0.95	0.7
	MINIMUM	4.55	4.55	2.65	1.7	1.2	0.85	0.65	0.45

<b>BOOM SECTION 1+2+3+4</b>											
WORKING RADIUS(m)											
	5.0	6.0	7.0	8.0	9.0	10.0	11.0	12.0	12.9		
NET RATED LOAD(t)	2.95	2.55	2.15	1.85	1.5	1.2	0.95	0.8	0.45		
OUTRIGGERS EXTENDED TO	MAXIMUM	2.95	2.55	1.85	1.4	1.1	0.85	0.65	0.55	0.4	
	HALFWAY	2.95	2.55	1.85	1.4	1.1	0.85	0.65	0.55	0.4	
	MINIMUM	2.75	1.85	1.3	1.0	0.75	0.55	0.43	0.33	0.24	

<b>BOOM SECTION 1+2+3+4+5</b>												
WORKING RADIUS(m)												
	6.0	8.0	9.0	10.0	11.0	12.0	13.0	14.0	15.0	15.8		
NET RATED LOAD(t)	2.35	1.7	1.4	1.2	1.0	0.85	0.7	0.6	0.5	0.4		
OUTRIGGERS EXTENDED TO	MAXIMUM	2.35	1.5	1.15	0.95	0.75	0.6	0.5	0.4	0.3	0.25	
	HALFWAY	2.35	1.5	1.15	0.95	0.75	0.6	0.5	0.4	0.3	0.25	
	MINIMUM	1.95	1.05	0.8	0.65	0.5	0.4	0.3	0.23	0.17	0.13	

<b>BOOM SECTION 1+2+3+4+5+6</b>									
WORKING RADIUS(m)									
	8.0	10.0	12.0	14.0	16.0	18.0	18.6		
NET RATED LOAD(t)	1.35	1.0	0.8	0.6	0.4	0.25	0.2		
OUTRIGGERS EXTENDED TO	MAXIMUM	1.35	1.0	0.65	0.45	0.3	0.2	0.15	
	HALFWAY	1.35	1.0	0.65	0.45	0.3	0.2	0.15	
	MINIMUM	1.1	0.7	0.45	0.28	0.17	0.09	0.06	

**CAUTIONS NET RATED LOADS**

- Net rated loads are performance when the crane is placed level and is based on actual working radius including boom deflection under loaded. Net rated loads are also based on strength and stability of the crane.
- 'Outriggers extended to maximum' means the state that the inner box is extended to the position where the 2nd ● mark is visible.
- 'Outriggers extended to halfway' means the state that the inner box is extended to the position where the 1st ● mark is visible.
- 'Outriggers extended to minimum' means the state that the inner box is extended to the position where the 1st ● mark is invisible.
- When each of 4 outriggers has been set to different extension, operate the crane by using the worst extended capacity.
- When each of boom sections being extended is exceeded even slightly, operate it by application of the capacity for the next boom section.
- Boom **1+2+3+4** means that the boom is extended to the position where the 1st ↘ mark on the 4th boom-section is visible.
- Boom **1+2+3+4+5** means that the boom is extended to the position where the 2nd ↘ mark on the 4th boom-section is visible.
- Operate the crane using the rated load capacity data under the boom extension of: **1+2+3+4** when the ↘ mark on the 3rd boom-section goes beyond the 2nd boom section, regardless of the displacement, **1+2+3+4+5** when the 1st ↘ mark on the side plate of the 4th boom-section goes beyond the 3rd boom-section, regardless of the displacement, **1+2+3+4+5+6** when the 2nd ↘ mark on the side plate of the 4th boom-section goes beyond the 3rd boom-section, regardless of the displacement.

UCE 02.68 GB URW706

**UCE 02.68      URW 706**



**⚠ Points to observe in handling outriggers**

**UNIC**

- Always ensure the outriggers are placed on firm and uniform ground or use road plates or similar to prevent sinking or other movement. Where possible always operate with the outriggers set to the maximum position
- Always extend the inner boxes before extending the vertical cylinders. Retract in reverse order
- Always ensure that the outrigger locking pins are correctly inserted and secured before extending the outriggers
- Always ensure that the outriggers are correctly stowed before travelling

**⚠ Extending Outriggers**

**UNIC**

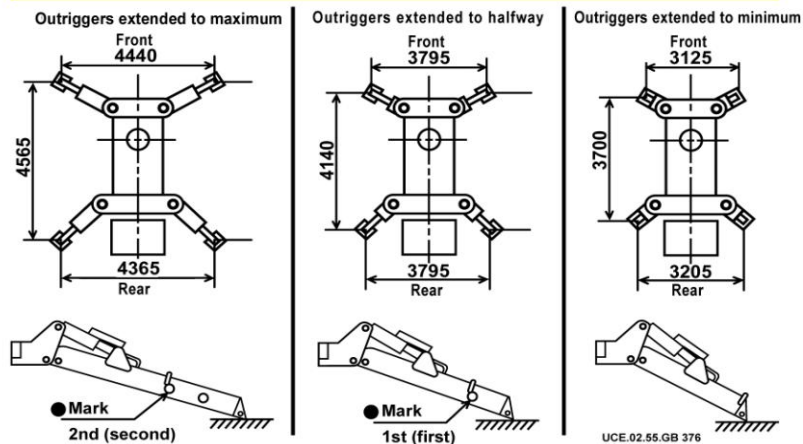

UCE 02.55      URW376

**⚠ Points to observe in handling outriggers**

**UNIC**

- Always ensure the outriggers are placed on firm and uniform ground or use road plates or similar to prevent sinking or other movement. Where possible always operate with the outriggers set to the maximum position
- Always extend the inner boxes before extending the vertical cylinders. Retract in reverse order
- Always ensure that the outrigger locking pins are correctly inserted and secured before extending the outriggers
- Always ensure that the outriggers are correctly stowed before travelling

**⚠ Extending Outriggers**

**UNIC**

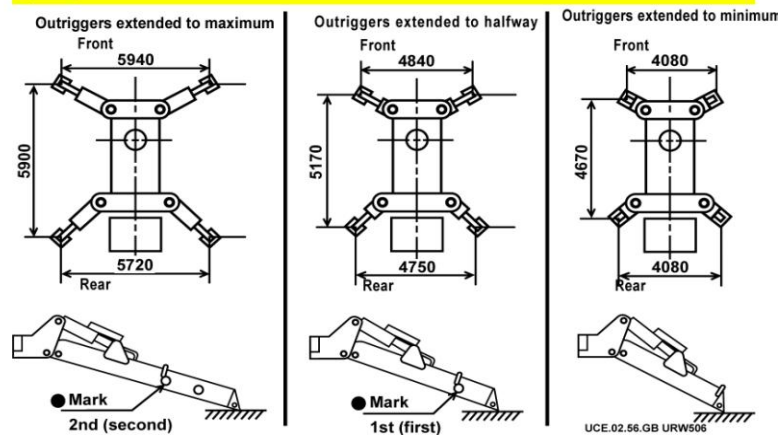

UCE 02.56      URW 506



## CAUTION OUTRIGGER OPERATION

- When operating the crane, be sure to use outriggers to keep the crane body to be level.
- Set up the outriggers on a flat and solid ground and in principle, operate the crane with the outriggers fully extended.
- When extending outriggers halfway, align the inner box extended either with the halfway, or the minimum extension according to the "arrangement of outrigger extension" and operate the crane each under the halfway or the minimum capacity specified in the net rated loads.
- Do not extend vertical cylinder and inner box with the outriggers retracted.
- Retract vertical cylinders before the stored outriggers are to be rotated.
- Outriggers may become hard to be rotated when the floats touch to the supports mounted lower side.
- When setting up outriggers, be sure to touch them to the ground with vertical cylinders after each inner box has been extended.
- When swinging the boom with a cargo lifted up, stability of the crane is different in the cargo lifted in front and rear and on the right and left. Operate the crane with the working radius as short as possible and paying attention that it will not be overturned.
- When storing outriggers, be sure to retract the inner boxes to their extremes after each vertical cylinder has fully been retracted.
- When outriggers are to be extended or stored, be sure to insert the pins so that outriggers may not be rotated unexpectedly.
- Be sure to store the outriggers before traveling.

## ARRANGEMENT OF OUTRIGGER EXTENSION

Outriggers extended to maximum

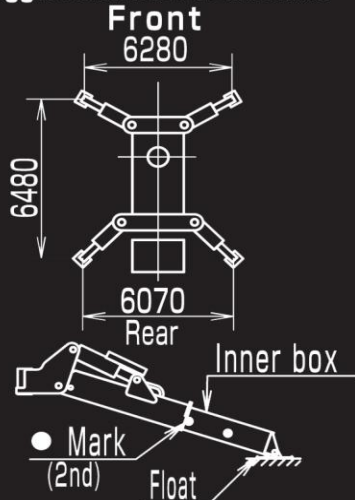

Outriggers extended halfway

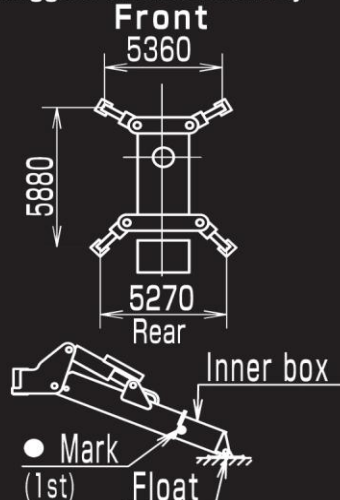

Outriggers extended to minimum

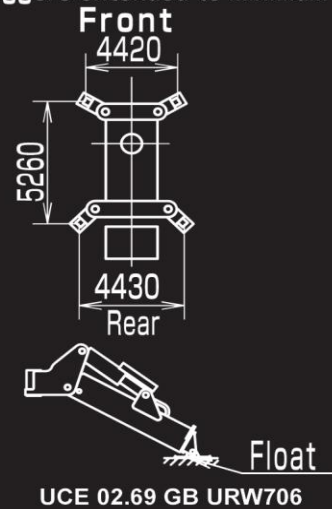

UCE 02.69

URW706

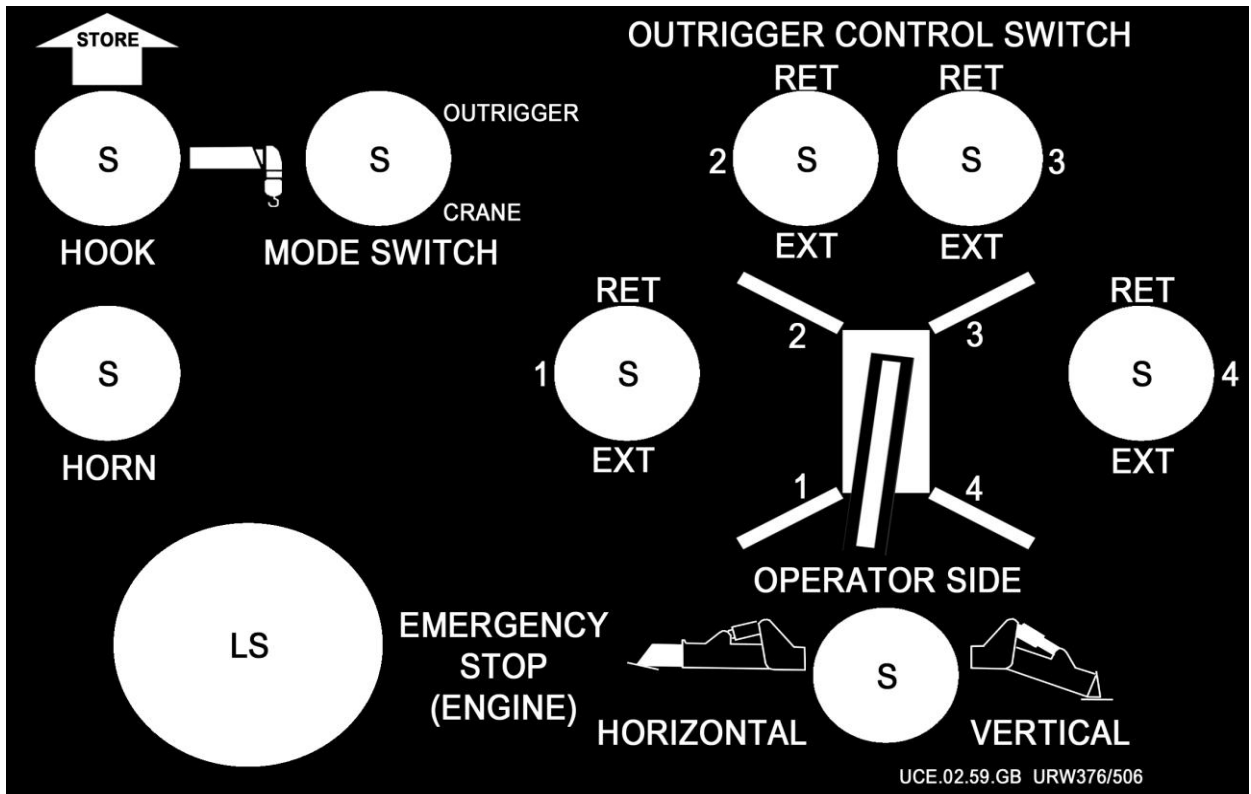

UCE 02.59

URW 376 / 506

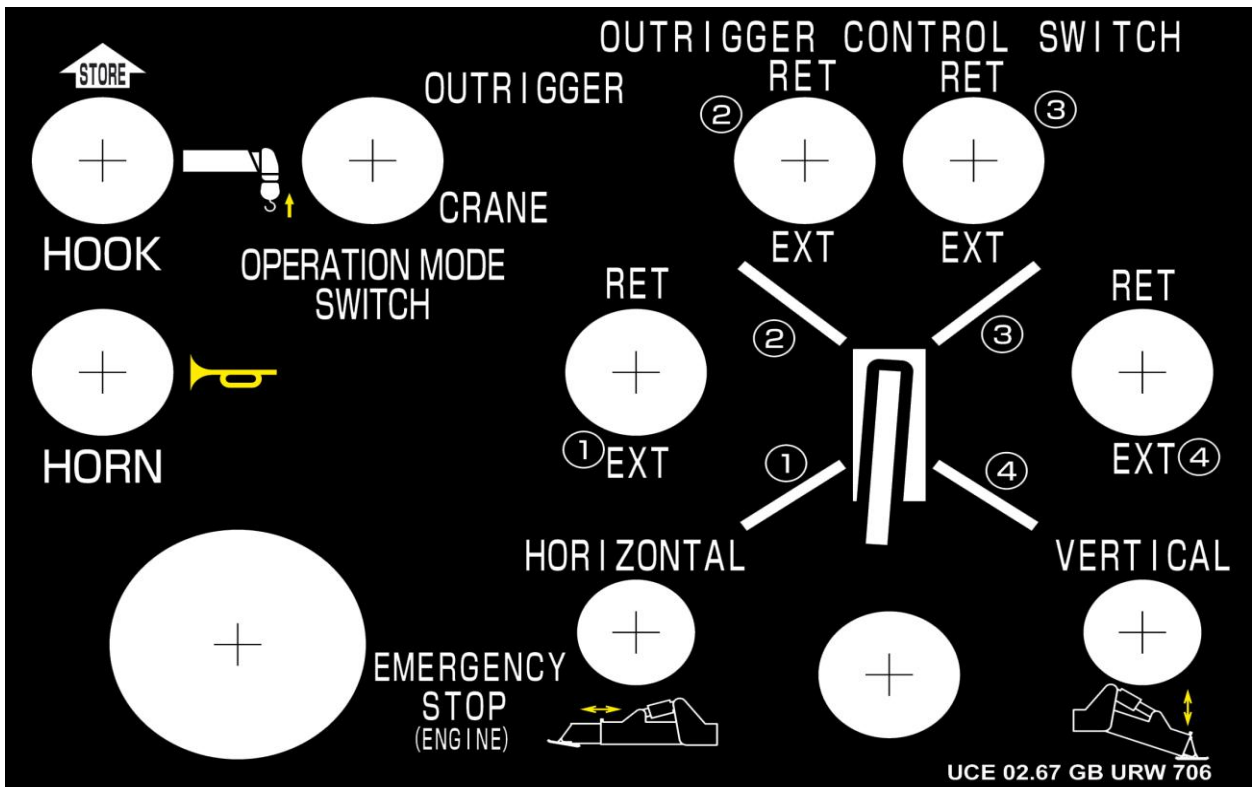

UCE 02.67

URW 706

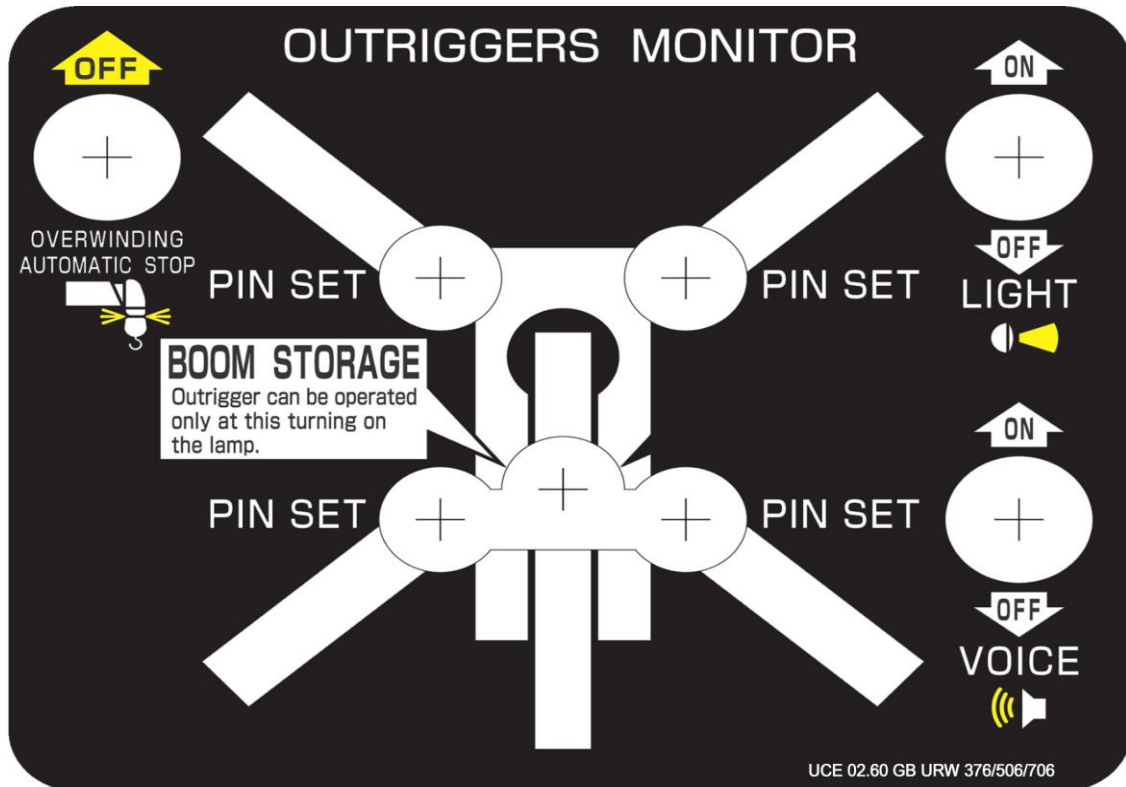

UCE 02.60

URW 376 / 506 / 706





### OUTRIGGER MODE INDICATOR LAMP

- CAUTION! When indicator lamp is lit the crane is in outrigger mode. No crane operations are possible

LAMP	OPERATION MODE	OPERATIONS POSSIBLE
ON	OUTRIGGER MODE	OUTRIGGERS ONLY
OFF	CRANE MODE	CRANE ONLY

UCE.02.61.GB URW376/506

### UCE 02.61 URW 376 / 506 / 706

MANUAL/  
RADIO REMOTE

LAMP	POSSIBLE OPERATION
ON	RADIO CONTROL
OFF	MANUAL

The operation mode is changed with the mode selection switch

**MODE SELECTION SWITCH**

UCE.02.62.GB URW376/506

### UCE 02.62 URW 376 / 506 / 706

### EMERGENCY OPERATION OF OUTRIGGERS

If outriggers fail to function normally, temporary (emergency) operation may be taken using the following steps. After emergency operation is used, contact your nearest authorised UNIC dealer for inspection and repair before next usage.

- Remove covers at the 2 places indicated in Figure 1.
- Select 'MANUAL' mode on the mode selector switch
- Return the boom to its stored position. (Ensure the boom stored light is lit on the outrigger monitor panel)
- Select the valve that matches the outrigger you want to extend or retract
- Select the control valve matching either the horizontal (inner box) or vertical (vertical cylinder) of the outrigger that you want to operate. Push and hold the solenoid valve button with a thin bar such as a screwdriver.
- Operate the control lever of the chosen outrigger with the solenoid valve button depressed.

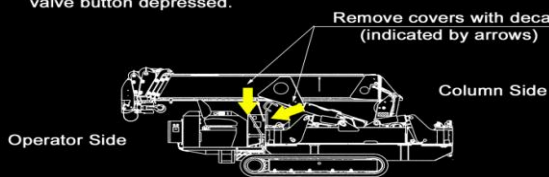

Figure 1 Covers to be removed

Table 1 How to operate outrigger valve for extension and retraction

Actuating direction of outrigger	Operation
Extend	Turn by 90° with B depressed to lock
Retract	Turn by 90° with A depressed to lock

Note: Turn back 90° to unlock the button



Figure 2 Outrigger valve for extension and retraction

Table 2 How to operate outrigger valve for horizontal and vertical

Outrigger to be operated		
Outrigger 1	Vertical	Control lever with '1' depressed
	Horizontal	Control lever with '2' depressed
Outrigger 2	Vertical	Control lever with '5' depressed
	Horizontal	Control lever with '6' depressed
Outrigger 3	Vertical	Control lever with '7' depressed
	Horizontal	Control lever with '8' depressed
Outrigger 4	Vertical	Control lever with '3' depressed
	Horizontal	Control lever with '4' depressed



Note: Take care not to damage the electrical wiring when removing or replacing panels and screws or pushing the solenoid buttons

UCE.02.63.GB URW376/506

### UCE 02.63 URW 376 / 506 / 706

### POSITION OF OUTRIGGER VALVE FOR EXTENSION AND RETRACTION

- Remove the cover to operate the outrigger valve for extension and retraction
- Vertical and horizontal parts of outrigger can only be extended from the cover side (Refer to the decal Emergency Outrigger Operation for further details)
- Depress the related button on the solenoid valve depending on the action chosen (To lock the button, turn 90° when it is depressed)

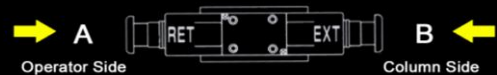

Note: Turn back 90° to unlock the button

UCE.02.64.GB URW376/506

### UCE 02.64 URW 376 / 506 / 706



## PREPARATION FOR CRANE OPERATION AND TRAVELLING

### ■ Preparation before crane operation

1. Shift the interlock for crane-crawl to 'CRANE' position.
2. Turn on the voice switch. (Ensure the voice switch remains ON during crane operations)
3. Rotate outriggers manually and insert set pins. (Ensure all outrigger lights are lit on outrigger monitor panel)
4. Change operation mode switch to 'OUTRIGGER' (Voice message: 'Outrigger Mode, Outrigger Moving is heard and outrigger mode indicator lamp lights)
5. Ensure the ground is solid, even and uniform. Extend the inner boxes fully, use the vertical cylinders to lower the outriggers to the ground. Level the crane using the outrigger controls and bubble level. Raise the crane chassis approximately 50mm.
6. Return the operation mode switch to 'CRANE' (Voice message: 'Crane Mode' is heard and the outrigger mode indicator lamp turns off)
7. Lower the hook until the overwind alarm weight is free

### ● This completes preparation for crane operation

### ■ Preparation before travelling crane (storing hook)

1. Retract the boom sections completely and rotate the boom to line up with the 'storing boom position' sticker the lower the boom fully. (Ensure that the boom storage lamp on the outrigger monitor panel is extinguished)
2. When the hook strikes the overwind alarm detector weight, the hook stops winding up.
3. Select and hold the hook storing switch to 'STORAGE' to store the hook.
4. Return the operation mode switch to 'OUTRIGGER' (Voice message: 'Outrigger Mode, Outrigger Moving is heard and outrigger mode indicator lamp lights)
5. After the vertical cylinders have been fully retracted, retract the inner boxes fully
6. Remove the set pins and rotate the outriggers manually to their storage positions. Ensure the set pins are inserted fully and that all lights (except boom storage light) are extinguished on the outrigger monitor panel.
7. Shift the crane-crawl interlock to 'CRAWL' position

### ● This completes preparation for travelling crane (storing hook)

### ■ NOTE:

- When the hook strikes the overwind alarm detection weight, operation of winding up, raising the boom or extending the boom is disabled.
- Crane cannot be operated unless all set pins are correctly in place (ALL outrigger lights must be lit on the outrigger monitor panel)
- Outriggers may only be operated when the boom is in its stored position (Boom storage light is lit on outrigger monitor panel)
- (Voice message: 'Change Control Mode' will be heard when selection between inner boxes and vertical cylinders of outriggers is changed)

UCE.02.65.GB URW376/506

**UCE 02.65**

**URW 376 / 506 / 706**



**UCE 02.70      URW 706**

**NET RATED LOADS (FOR SEARCHER HOOK)**

WORKING RADIUS (m)	NET RATED LOAD (kg)		
	OUTRIGGERS EXTENDED TO MAXIMUM	OUTRIGGERS EXTENDED TO HALFWAY	OUTRIGGERS EXTENDED TO MINIMUM
7.0	800	800	800
8.0	800	800	610
9.0	800	700	420
10.0	800	550	250
10.5	800	490	200
11.0	650	430	160
11.5	550	370	120
12.0	470	310	100
13.0	330	230	
14.0	260	150	
15.0	210	100	
16.0	170		
17.0	130		
18.0	100		
20.8			

**PROHIBITED AREA OF CRANE OPERATION**

**CAUTIONS**

- Net rated loads are performance when the crane is placed level and is based on an actual working radius including boom deflection under load.
- Net rated loads are also based on strength and stability of the crane.
- Net rated loads must be reduced in accordance with wind, ground condition and operation speed.
- In order to make correct operation, read the instruction manual carefully before crane operation.

UCE 02.71 GB URW706

**UCE 02.71      URW 706**



<b>Weight of pieces</b>		URW506CDE
<ul style="list-style-type: none"> <li>○ Boom</li> <li>○ Telescoping cylinders</li> </ul>	910kg	
<ul style="list-style-type: none"> <li>○ Outrigger</li> <li>○ Outrigger cylinder(Vertical)</li> <li>○ Outrigger cylinder(Horizontal)</li> </ul>	270kg×4=1080kg	
<ul style="list-style-type: none"> <li>○ Frame</li> <li>○ Column</li> <li>○ Derrick cylinder</li> <li>○ Power unit</li> </ul>	1480kg (1630kg;Power unit)	
<ul style="list-style-type: none"> <li>○ Carrier</li> </ul>	1410kg	
		09HT81080

**09HT 81080**

**URW 506**

<b>CENTER OF GRAVITY</b>	<b>MASS</b>	
<ul style="list-style-type: none"> <li>● Boom</li> <li>● Telescoping cylinders</li> </ul>	1800kg	
<ul style="list-style-type: none"> <li>● Outrigger</li> <li>● Outrigger cylinder(Vertical)</li> <li>● Outrigger cylinder(Horizontal)</li> </ul>	390kg×4=1560kg	
<ul style="list-style-type: none"> <li>● Frame</li> <li>● Column</li> <li>● Derrick cylinder</li> <li>● Power unit</li> </ul>	2590kg (2430kg;Power unit)	
<ul style="list-style-type: none"> <li>● Carrier</li> </ul>	2130kg	
		09KK81161-W706CDE

**09KK 81161**

**URW 706**





## Searcher Hook

### NET RATED LOAD CHART FOR SEARCHER HOOK

● For up to 5th stage extended boom

WORKING RADIUS (m)	NET RATED LOAD(kg)		
	OUTRIGGERS EXTENDED TO MAXIMUM	OUTRIGGERS EXTENDED TO HALFWAY	OUTRIGGERS EXTENDED TO MINIMUM
2.0	500	500	500
3.0	500	500	500
4.0	500	500	500
5.0	500	500	500
6.0	420	420	350
7.0	340	340	200
8.0	290	270	130
9.0	250	200	80
10.0	220	150	50
11.0	200	110	PROHIBITED AREA OF CRANE OPERATIONS
12.0	180	80	
13.06	160	60	

#### CAUTIONS

- Net rated loads are performance when the crane is placed level and is based on an actual working radius including boom deflection under loaded.
- Net rated loads are also based on strength and stability of the crane.
- Net rated loads must be reduced in accordance with wind, ground condition and operation speed.
- Cranes must be operated according to the above proper charts.
- Never operate a crane without making sure the boom length and knowing which chart must be used at the time.
- In order to make correct operation, read the instruction manual carefully before crane operation.

● For 6th stage extended boom only

WORKING RADIUS (m)	NET RATED LOAD(kg)		
	OUTRIGGERS EXTENDED TO MAXIMUM	OUTRIGGERS EXTENDED TO HALFWAY	OUTRIGGERS EXTENDED TO MINIMUM
2.0	280	280	280
3.0	280	280	280
4.0	280	280	280
5.0	250	250	250
6.0	220	220	220
7.0	190	190	170
8.0	170	150	120
9.0	150	120	80
10.0	130	100	50
11.0	110	70	PROHIBITED AREA OF CRANE OPERATIONS
12.0	100	50	
13.0	80		
14.0	70		
15.25	50		

09HA37080-W376CDE

**09HA 37080**

**URW 376**

### NET RATED LOAD CHART FOR SEARCHER HOOK

● For up to 5th stage extended boom

WORKING RADIUS (m)	NET RATED LOAD(kg)		
	OUTRIGGERS EXTENDED TO MAXIMUM	OUTRIGGERS EXTENDED TO HALFWAY	OUTRIGGERS EXTENDED TO MINIMUM
2.0	500	500	500
3.0	500	500	500
4.0	500	500	500
5.0	500	500	500
6.0	500	500	500
7.0	500	500	500
8.0	500	500	450
9.0	500	470	350
10.0	450	400	250
11.0	400	330	200
12.0	350	250	150
13.0	300	200	130
13.99	250	150	100

#### CAUTIONS

- Net rated loads are performance when the crane is placed level and is based on an actual working radius including boom deflection under loaded.
- Net rated loads are also based on strength and stability of the crane.
- Net rated loads must be reduced in accordance with wind, ground condition and operation speed.
- Cranes must be operated according to the above proper charts.
- Never operate a crane without making sure the boom length and knowing which chart must be used at the time.
- In order to make correct operation, read the instruction manual carefully before crane operation.

● For 6th stage extended boom only

WORKING RADIUS (m)	NET RATED LOAD(kg)		
	OUTRIGGERS EXTENDED TO MAXIMUM	OUTRIGGERS EXTENDED TO HALFWAY	OUTRIGGERS EXTENDED TO MINIMUM
2.0	480	480	480
3.0	480	480	480
4.0	480	480	480
5.0	480	480	480
6.0	480	480	480
7.0	360	360	360
8.0	300	300	300
9.0	250	250	250
10.0	220	220	220
11.0	200	200	180
12.0	170	170	150
13.0	150	150	130
14.0	120	120	100
15.0	100	100	80
16.32	80	80	50

09HT37030-W506CDE

**09HT 37030**

**URW 506**

# Lifting Capacity 500kg

09HA37070-W376CDE

**09HA 37070**

**URW 376 / 506**

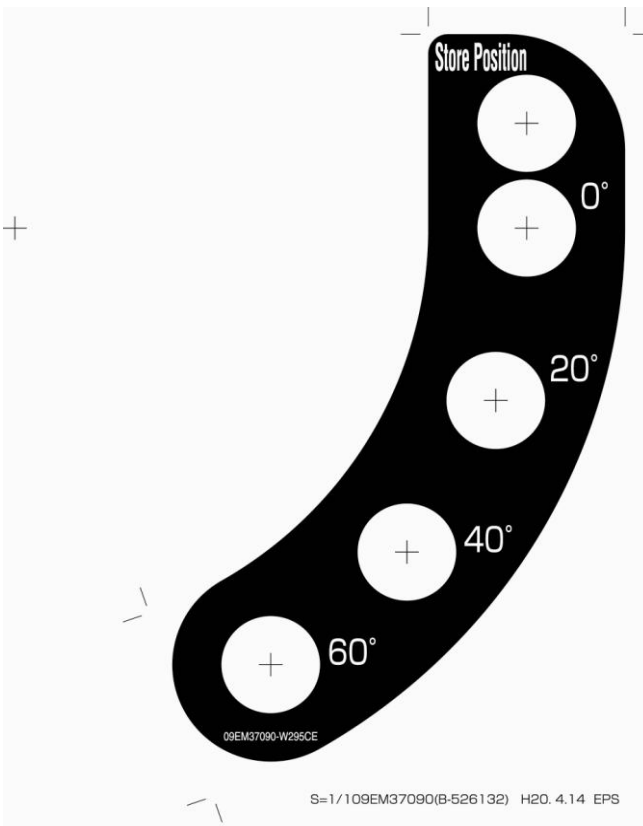

**09EM 37090**

**URW 376 / 506**

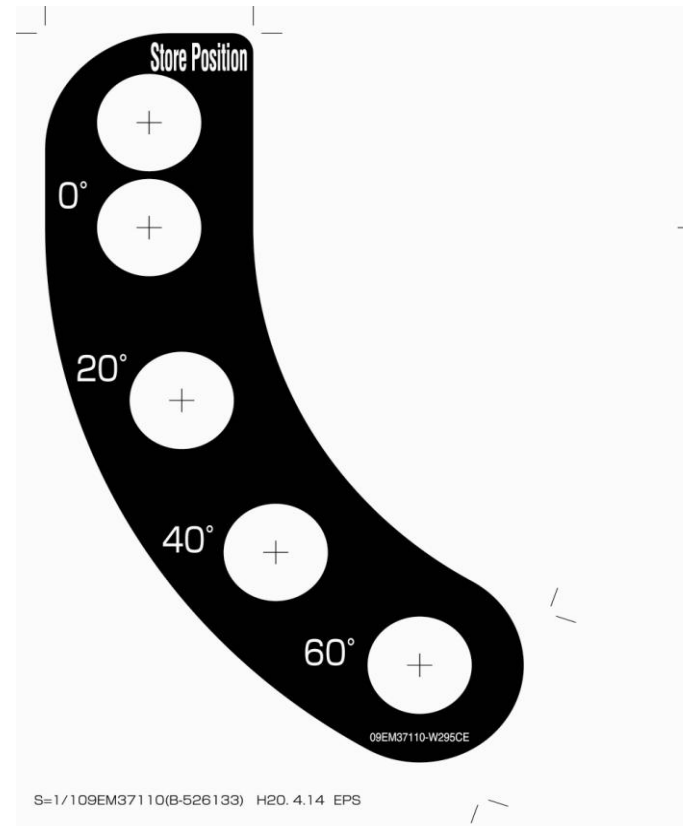

**09EM 37110**

**URW 376 / 506**

7 **DEFINITION OF TERMS**

a. **Outrigger extension**

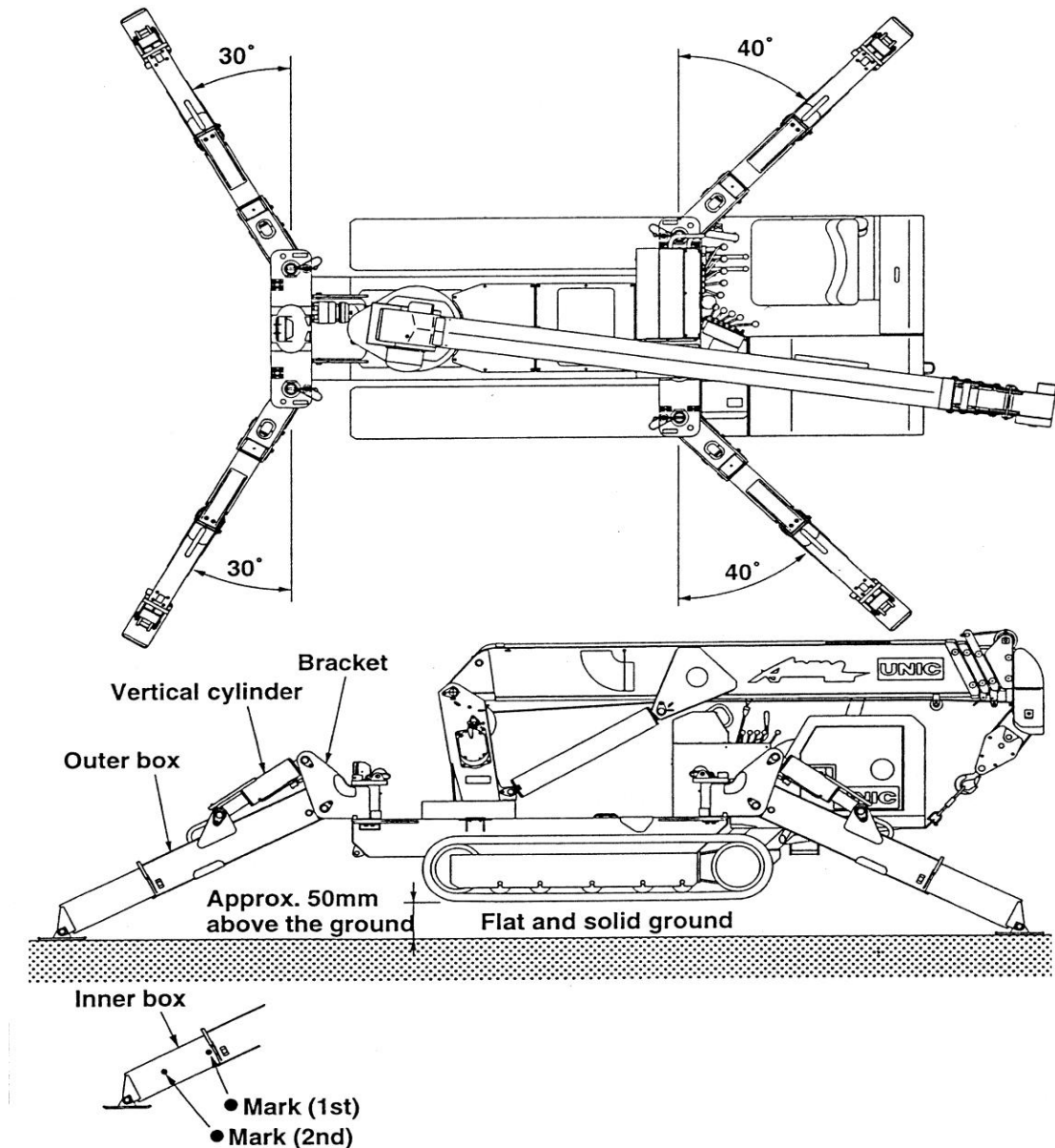

The figure above shows the outriggers extended to their extremes. Carry out operations by first ensuring the outriggers are on firm, level and uniform ground. This may require the use of timber or steel plates. Extend the outriggers to their fullest extent and raise the vehicle approximately 50mm from the ground, ensuring it is level in both horizontal axes.

Since the rated load varies according to how the outriggers are extended, the rated load has been set for 3 pre-determined extension positions.

The Figures below show the dimensions where the outriggers are set to 'maximum', 'halfway (intermediate)' and 'minimum'.

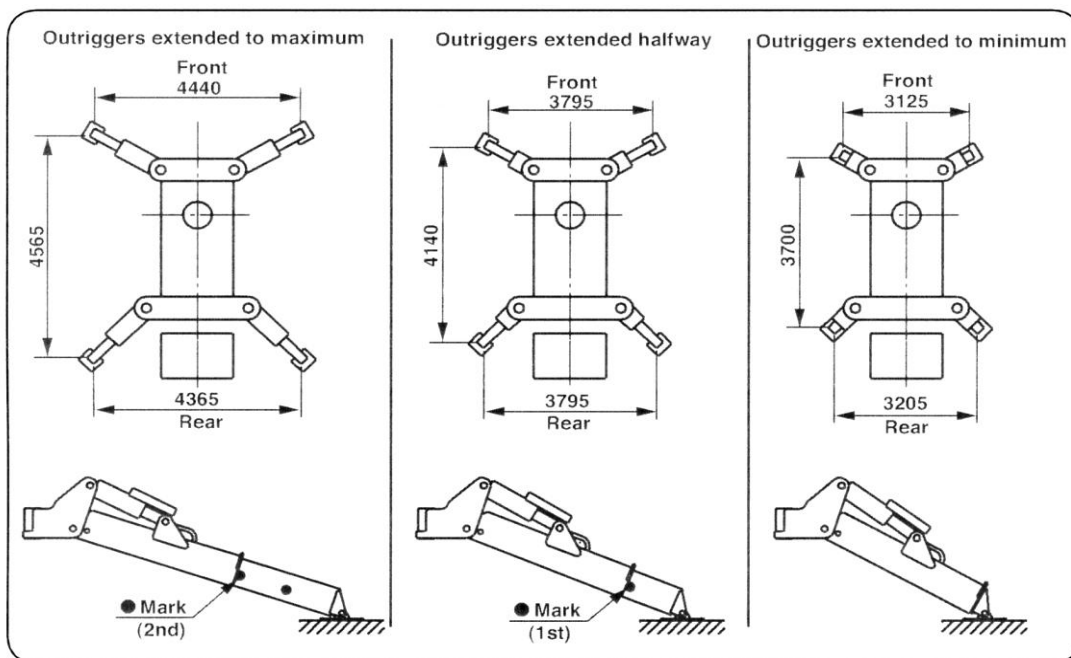

This example is of the URW376C. See Chapter 16 for URW506C and URW706C outrigger dimensions

'Outriggers extended to maximum' means that the inner box is extended to the point where both marks ● are visible

'Outriggers extended to halfway (intermediate)' means that the inner box is extended to a position where only the first mark ● is visible

'Outriggers extended to minimum' means that the inner box is not extended and no marks are visible

The Safe Load Indicator (SLI) is automatically switched to the correct duty by microswitches in the outrigger legs. The crane operator has no way of overriding this function. Therefore if any one of the outriggers is at a different extension to the others, the SLI will only allow the crane to be operated at the duty relevant to the shortest extension.





**b. How boom sections are extended URW 376C**

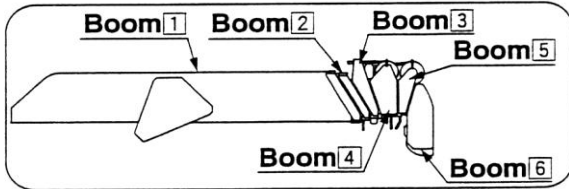

Boom : **1**

All boom sections are retracted

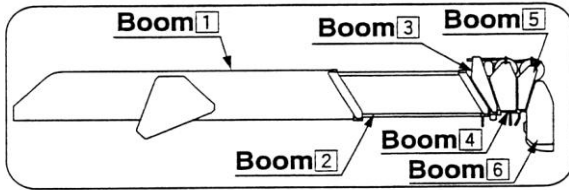

Boom : **1+2** or **2**

Only boom section 2 is extended

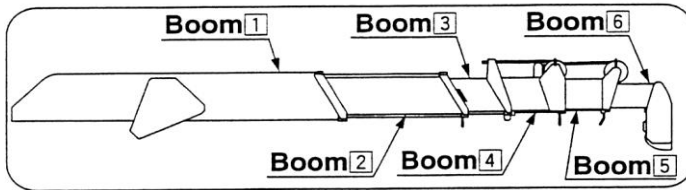

Boom : **1+2+3** or **3**

Boom sections 2 and 3 are extended to a position where the first mark on boom section 3 is visible

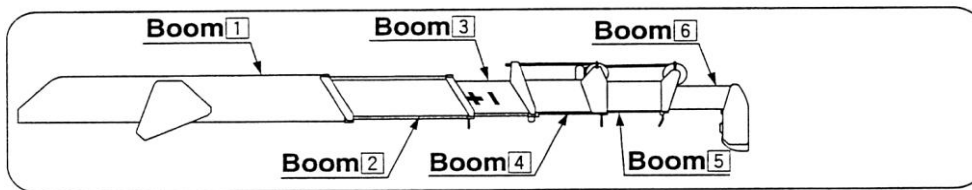

Boom : **1+2+3+4** or **4**

Boom sections are extended until the second mark on boom section 3 is visible

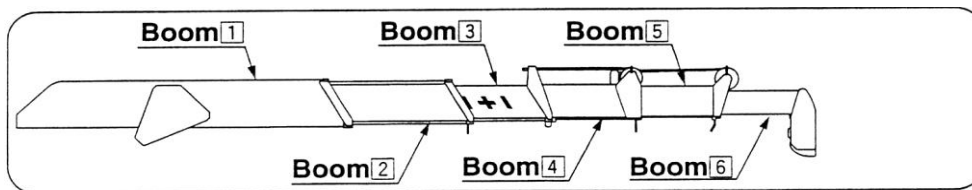

Boom : **1+2+3+4+5** or **5**

Boom sections are extended until the third mark on boom section 4 is visible

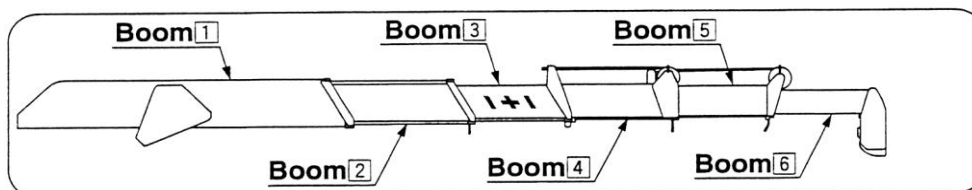

Boom : **1+2+3+4+5+6** or **6**

All boom sections are fully extended



**How boom sections are extended URW 506C & URW 706C**

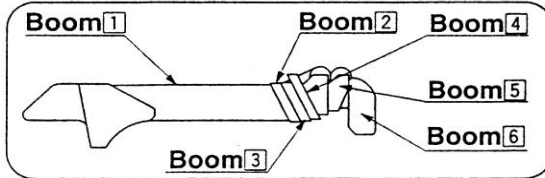

Boom : **1**

All boom sections are retracted

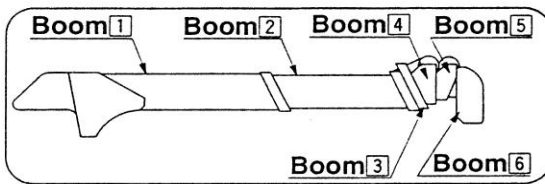

Boom : **1+2** or **2**

Only boom section 2 is extended

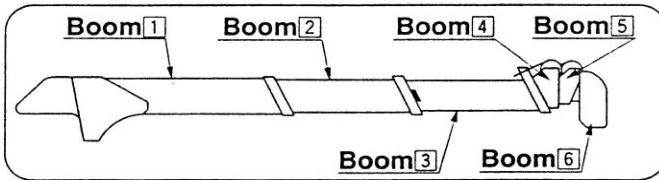

Boom : **1+2+3** or **3**

Boom sections 2 and 3 are extended to a position where the first mark on boom section 3 is visible

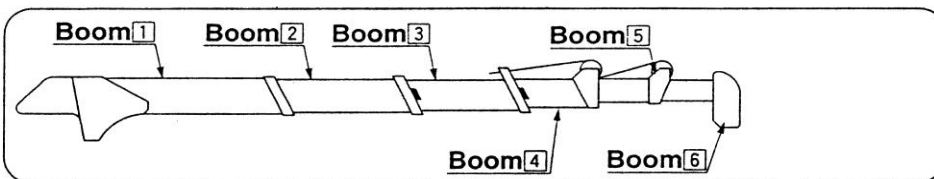

Boom : **1+2+3+4** or **4**

Boom sections are extended until the first mark on boom section 4 is visible

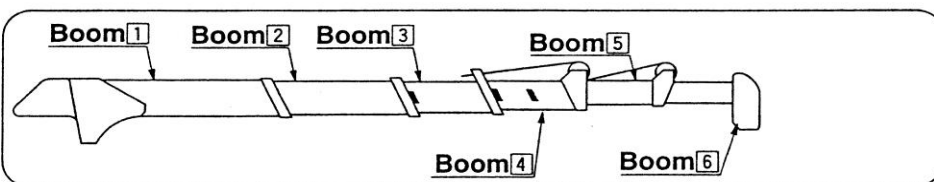

Boom : **1+2+3+4+5** or **5**

Boom sections are extended until the second mark on boom section 4 is visible

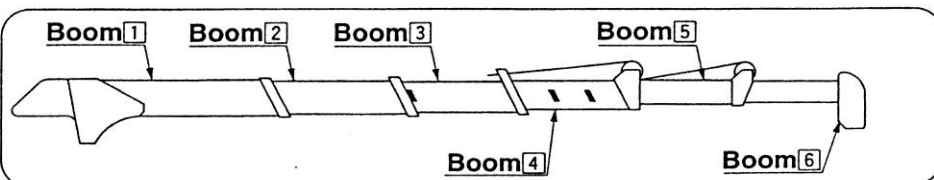

Boom : **1+2+3+4+5+6** or **6**

All boom sections are fully extended



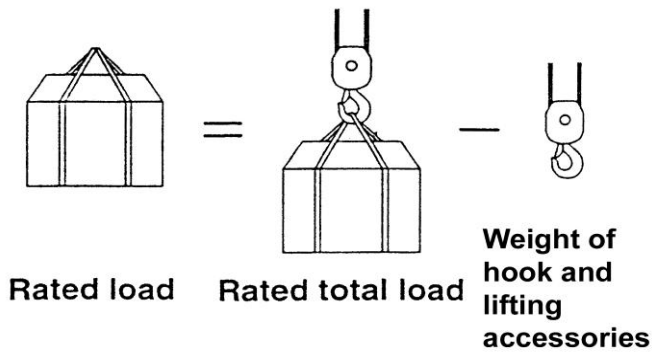

**c. Rated Load**

Net load that can be lifted determined on the basis of crane stability

**d. Rated Total Load**

Maximum load including hook and lifting accessories that can be lifted at a determined boom angle and boom length based on the stability of the crane

**e. Hoisting Load**

This is the actual load being lifted

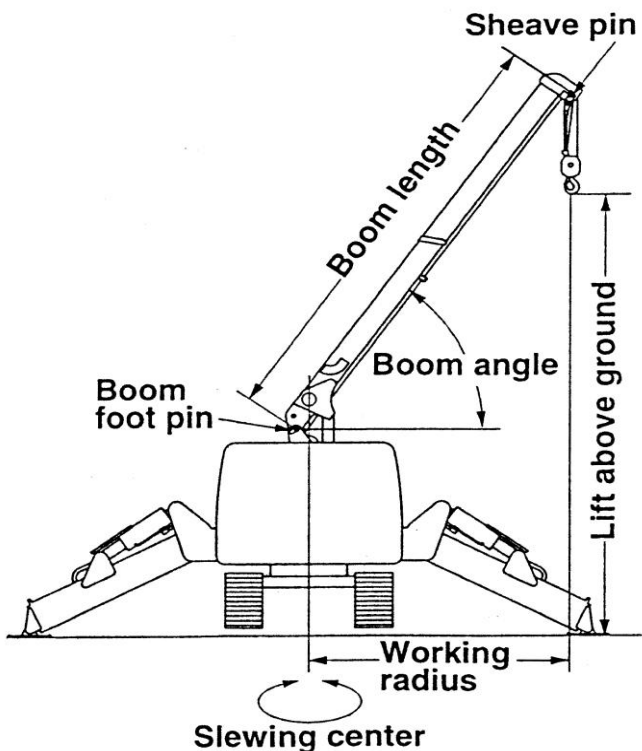

**f. Working Radius**

This is the horizontal distance from the centre of rotation of the column to the centre of the

**g. Boom Length**

This the distance from the boom foot pin to the sheave pin at the top of the boom

**h. Boom Angle**

This the angle between a horizontal line drawn from the boom foot pin and the axis line of the boom

**i. Lift above ground**

This refers to the vertical distance between the bottom of the hook and ground level when the hook is wound up until it is touching the Overwind Alarm detector weight



**Intentionally Blank**



**8 HOW TO REFER TO WORKING RANGE CHART AND RATED LOAD CHART**

These charts are placed in front of the crane operation levers. The method of interpreting these charts is illustrated below.

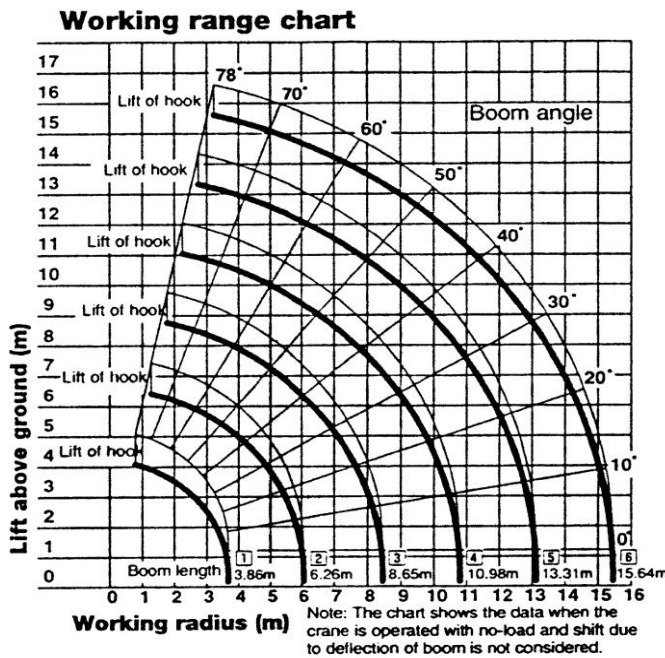

**a. Working Range Chart**

This chart shows the relationship between boom length and working radius, boom angle and lift above ground

**Important Note:** This range chart is for information purposes only and is not a working document. Please refer to the Working Range Chart for your model of crane

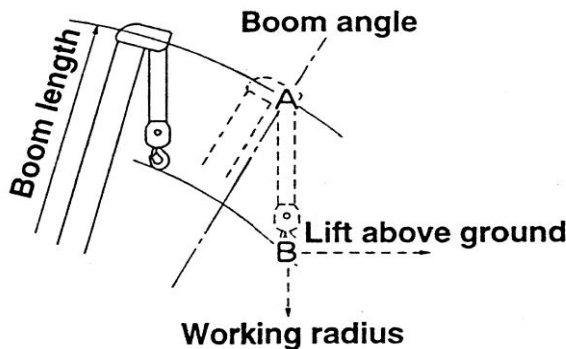

Although Point A and Point B follow the same track along the working radius, due to boom deflection Point A refers to the boom angle and Point B refers to the lift above ground

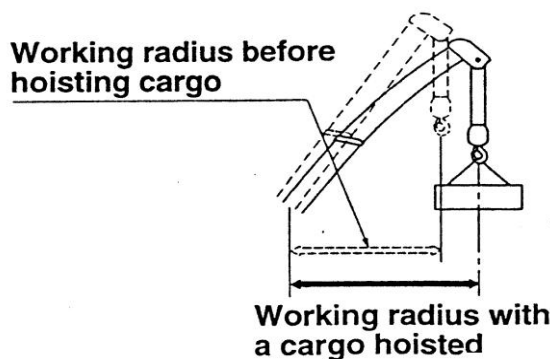

The working Range chart does not take into account of movement due to boom deflection.

Bear in mind that the actual working radius is somewhat greater due to this deflection when lifting a load.



**b. Rated Load Charts**

**N.B. These are not working documents. Refer to the charts fitted to your crane**



The chart shows lifting capacity when the crane is set up level with the outriggers extended. The data is based on actual working conditions which incorporates movement due to boom deflection under load. The rated loads specified are based upon the strength of the crane and stability of the carrier. Ensure that the rated load is correct for the extension of the outriggers

**i. URW 376C**

Boom Extension: 1, 1+2

Working Radius (m)		2,0	2,5	3,0	3,5	4,0	4,5	5,0	5,69
Rated Load (t)	Outriggers extended to Maximum	2,9	2,9	2,35	1,95	1,67	1,45	1,3	1,07
	Outriggers extended to Intermediate	2,9	2,9	2,32	1,92	1,57	1,25	0,99	0,77
	Outriggers extended to Minimum	2,9	2,9	2,17	1,5	1,12	0,9	0,72	0,47

Boom Extension: 1+2+3

Working Radius (m)		2,7	3,0	3,5	4,0	4,5	5,0	5,5	6,0	7,0	7,88
Rated Load (t)	Outriggers extended to Maximum	2,24	2,09	1,65	1,4	1,22	1,07	0,95	0,84	0,69	0,59
	Outriggers extended to Intermediate	2,24	2,06	1,65	1,39	1,17	1,0	0,82	0,64	0,45	0,37
	Outriggers extended to Minimum	2,24	2,06	1,57	1,22	1,02	0,83	0,65	0,51	0,3	0,19

Boom Extension: 1+2+3+4

Working Radius (m)		4,0	4,5	5,0	6,0	7,0	8,0	9,0	10,07
Rated Load (t)	Outriggers extended to Maximum	1,04	0,93	0,84	0,73	0,62	0,52	0,47	0,38
	Outriggers extended to Intermediate	1,03	0,92	0,83	0,67	0,5	0,38	0,28	0,2
	Outriggers extended to Minimum	1,03	0,82	0,64	0,47	0,31	0,22	0,13	0,09

Boom Extension: 1+2+3+4+5

Working Radius (m)		4,5	5,0	6,0	7,0	8,0	9,0	10,0	11,0	12,26
Rated Load (t)	Outriggers extended to Maximum	0,75	0,62	0,48	0,39	0,34	0,3	0,27	0,24	0,23
	Outriggers extended to Intermediate	0,75	0,62	0,47	0,39	0,32	0,27	0,22	0,17	0,13
	Outriggers extended to Minimum	0,75	0,62	0,4	0,25	0,18	0,13	0,09	0,06	0,01

Boom Extension: 1+2+3+4+5+6

Working Radius (m)		4,9	5,5	6,0	7,0	8,0	9,0	10,0	11,0	12,0	13,0	14,45
Rated Load (t)	Outriggers extended to Maximum	0,3	0,27	0,25	0,22	0,2	0,18	0,16	0,14	0,13	0,11	0,1
	Outriggers extended to Intermediate	0,3	0,27	0,25	0,22	0,2	0,18	0,16	0,12	0,09	0,06	0,04
	Outriggers extended to Minimum	0,3	0,27	0,25	0,22	0,17	0,11	0,08	0,05	0,03	0,02	0,01



**ii. URW 506C**

Boom Extension: 1, 1+2, 1+2+3

Working Radius (m)		3,0	3,4	4,0	4,5	5,0	5,5	6,0	6,5	7,0	7,5	8,53
Rated Load (t)	Outriggers extended to Maximum	3,0	3,0	2,4	2,1	1,85	1,7	1,55	1,4	1,3	1,2	1,0
	Outriggers extended to Intermediate	3,0	3,0	2,4	2,1	1,85	1,7	1,4	1,2	1,05	0,85	0,62
	Outriggers extended to Minimum	3,0	3,0	2,4	2,0	1,65	1,35	1,1	0,9	0,75	0,6	0,45

Boom Extension: 1+2+3+4

Working Radius (m)		4,0	4,5	5,0	5,5	6,0	7,0	8,0	9,0	10,0	10,86
Rated Load (t)	Outriggers extended to Maximum	2,0	1,8	1,6	1,45	1,3	1,1	0,95	0,85	0,75	0,64
	Outriggers extended to Intermediate	2,0	1,8	1,6	1,45	1,3	1,05	0,7	0,6	0,45	0,39
	Outriggers extended to Minimum	2,0	1,8	1,6	1,35	1,1	0,75	0,5	0,4	0,3	0,25

Boom Extension: 1+2+3+4+5

Working Radius (m)		5,0	5,5	6,0	7,0	8,0	9,0	10,0	11,0	12,0	13,19
Rated Load (t)	Outriggers extended to Maximum	1,0	0,92	0,85	0,7	0,6	0,55	0,5	0,45	0,4	0,35
	Outriggers extended to Intermediate	1,0	0,92	0,85	0,7	0,6	0,52	0,45	0,39	0,3	0,25
	Outriggers extended to Minimum	1,0	0,92	0,85	0,7	0,5	0,4	0,3	0,25	0,2	0,17

Boom Extension: 1+2+3+4+5+6

Working Radius (m)		6,0	7,0	8,0	9,0	10,0	11,0	12,0	13,0	14,0	15,52
Rated Load (t)	Outriggers extended to Maximum	0,5	0,4	0,35	0,3	0,25	0,25	0,2	0,2	0,15	0,15
	Outriggers extended to Intermediate	0,5	0,4	0,35	0,3	0,25	0,25	0,2	0,2	0,15	0,15
	Outriggers extended to Minimum	0,5	0,4	0,35	0,3	0,25	0,23	0,2	0,17	0,15	0,1

This chart shows the load that can be lifted for a specified combination of boom length and working radius.



**c. Rated Load Chart URW 706C**

Boom Extension: 1

Working Radius (m)		2,7	3,0	3,5	4,0	4,3
Rated Load (t)	Outriggers extended to Maximum	6,0	6,0	5,45	4,85	3,95
	Outriggers extended to Intermediate	6,0	6,0	5,45	4,85	3,95
	Outriggers extended to Minimum	6,0	6,0	5,45	4,55	3,75

Boom Extension: 1+2

Working Radius (m)		2,0	3,0	3,5	4,0	5,0	6,0	7,0	7,2
Rated Load (t)	Outriggers extended to Maximum	6,0	6,0	5,35	4,75	3,75	2,95	2,25	2,0
	Outriggers extended to Intermediate	6,0	6,0	5,35	4,75	3,75	2,45	1,7	1,55
	Outriggers extended to Minimum	6,0	6,0	5,35	4,65	2,55	1,65	1,15	1,05

Boom Extension: 1+2+3

Working Radius (m)		2,7	4,0	5,0	6,0	7,0	8,0	9,0	10,0	10,1
Rated Load (t)	Outriggers extended to Maximum	4,55	4,55	3,65	2,95	2,4	1,8	1,35	0,95	0,95
	Outriggers extended to Intermediate	4,55	4,55	3,65	2,95	1,75	1,3	0,95	0,7	0,7
	Outriggers extended to Minimum	4,55	4,55	2,65	1,7	1,2	0,85	0,65	0,45	0,4

Boom Extension: 1+2+3+4

Working Radius (m)		5,0	6,0	7,0	8,0	9,0	10,0	11,0	12,0	12,9
Rated Load (t)	Outriggers extended to Maximum	2,95	2,55	2,15	1,85	1,5	1,2	0,95	0,8	0,45
	Outriggers extended to Intermediate	2,95	2,55	1,85	1,4	1,1	0,85	0,65	0,55	0,4
	Outriggers extended to Minimum	2,75	1,85	1,3	1,0	0,75	0,55	0,43	0,33	0,24

Boom Extension: 1+2+3+4+5

Working Radius (m)		6,0	8,0	9,0	10,0	11,0	12,0	13,0	14,0	15,0	15,8
Rated Load (t)	Outriggers extended to Maximum	2,35	1,7	1,4	1,2	1,0	0,85	0,7	0,6	0,5	0,4
	Outriggers extended to Intermediate	2,35	1,5	1,15	0,95	0,75	0,6	0,5	0,4	0,3	0,25
	Outriggers extended to Minimum	1,95	1,05	0,8	0,65	0,5	0,4	0,3	0,23	0,17	0,13

Boom Extension: 1+2+3+4+5+6

Working Radius (m)		8,0	10,0	12,0	14,0	16,0	18,0	18,6
Rated Load (t)	Outriggers extended to Maximum	1,35	1,0	0,8	0,6	0,4	0,25	0,2
	Outriggers extended to Intermediate	1,35	1,0	0,65	0,45	0,3	0,2	0,15
	Outriggers extended to Minimum	1,1	0,7	0,45	0,28	0,17	0,09	0,06





**URW 376 Searcher Hook**  
**Net Rated Loads**

Working Radius (m)	Net Rated Load (kg)		
	Outrigger Extend to Maximum	Outrigger Extend to Halfway	Outrigger Extend to Minimum
2.0	280	280	280
3.0	280	280	280
4.0	280	280	280
5.0	250	250	250
6.0	220	220	220
7.0	190	190	170
8.0	170	150	120
9.0	150	120	80
10.0	130	100	50
11.0	110	70	<b>PROHIBITED AREA OF CRANE OPERATION</b>
12.0	100	50	
13.0	80	<b>PROHIBITED AREA OF CRANE OPERATION</b>	
14.0	70		
15.25	50		

**URW 506 Searcher Hook**  
**Net Rated Loads**

Working Radius (m)	Net Rated Load (kg)		
	Outrigger Extend to Maximum	Outrigger Extend to Halfway	Outrigger Extend to Minimum
2.0	480	480	480
3.0	480	480	480
4.0	480	480	480
5.0	480	480	480
6.0	480	480	480
7.0	360	360	360
8.0	300	300	300
9.0	250	250	250
10.0	220	220	220
11.0	200	200	200
12.0	170	170	170
13.0	150	150	150
14.0	120	120	120
15.0	100	100	80
16.32	80	80	50



**URW 706 Extension Jib**  
**Net Rated Loads**

BOOM ANGLE	TILT ANGLE (°)			
	0°	20°	40°	60°
80°	800	800	600	600
75°	800	800	600	600
70°	700	700	500	500
65°	600	600	400	400
60°	500	500	<b>PROHIBITED AREA OF CRANE OPERATION</b>	
55°	400	400		
50°	300	300		
40°	<b>PROHIBITED AREA OF CRANE OPERATION</b>			
30°				
20°				
10°				
0°	<b>PROHIBITED AREA OF CRANE OPERATION</b>			

9 **DESCRIPTION OF CONTROLS**

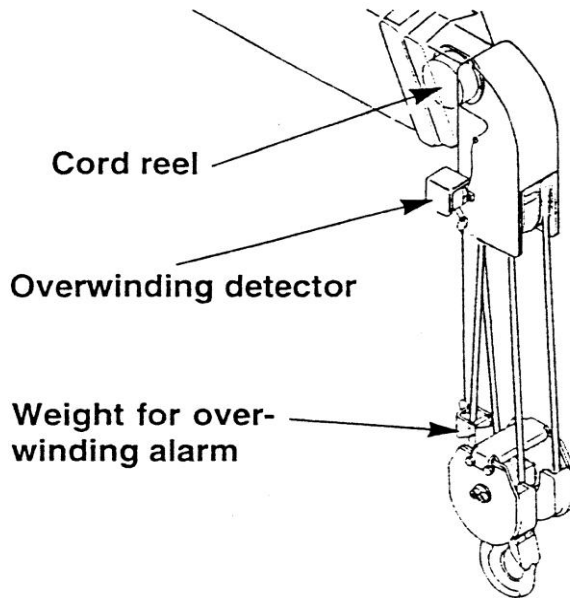

a. **Overwinding Alarm**

i. **Function of overwinding alarm**

The device automatically sounds the warning horn to warn the operator that the hook is approaching the top of the boom and that there is a danger of the wires being overwound if hoisting is carried on.

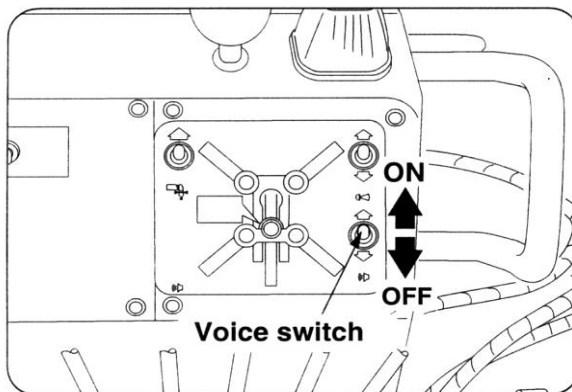

ii. **Operating procedures**

- Ensure the voice warning switch is set to ON before crane operation starts.
- If the voice alarm sounds during hoisting up or telescoping the boom, stop operations immediately and lower the hook or retract the boom



**Do not tamper with the length of the overwind alarm detector wire. This against the law and could also endanger life.**



**If the wires connecting the alarm at the top of the boom are broken, obviously the alarm will not function. Check the wires for breaks as part of your pre-use inspection.**

**INTERFERENCE WITH SAFETY SYSTEM PARTICULARLY THE ANTI-TWO SYSTEM, MAY LEAD TO DEATH AND WILL ALMOST CERTAINLY LEAD TO THE OPERATORS CRIMINAL PROSECUTION COMPLETE WITH ACCOMPANYING FINE AND IMPRISONMENT.**

**b. Automatic Overwinding Stop**

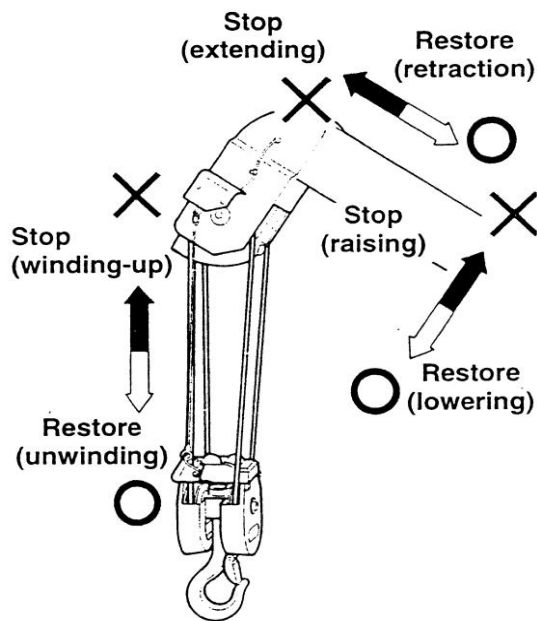

**i. Function of Automatic Stop**

When the overwinding alarm detector is touched by the hook, the automatic stop will halt the following functions, raising the hook, raising or extending the boom.

To allow normal actions to continue, reverse the control direction that caused the stop and alarm to function.

**N.B. Since the viscosity of hydraulic oil increases in cold conditions the raising and lowering of the hook may not stop exactly where you release the controls. This may lead to it inadvertently hitting the automatic stop detector. Wait until the oil has reached its operating temperature range before carrying on operations.**

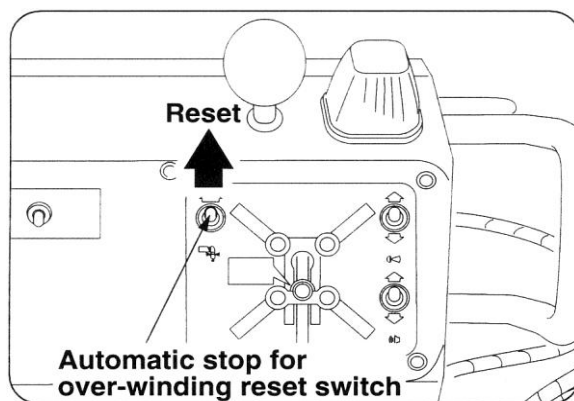

**ii. Resetting the Automatic Stop if it is malfunctioning**

If the crane cannot be operated due to automatic stop failure. Reset the automatic stop and store the crane.

- Turn the automatic stop reset switch to 'Reset'. Raise the hook, extend or raise the boom by the relevant operating lever. Stow the crane.



**These are only temporary measures to enable the crane to be stowed. Ensure that the crane is repaired by an authorised UNIC dealer before using it again.**



c. **Load Indicator (With Angle Indicator)**

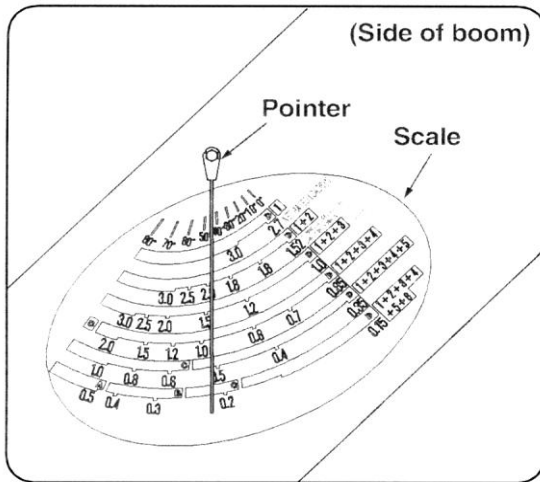

The indicator reads the rated load corresponding to the boom extension and angle. This is the maximum load that can be lifted at that point



The load indicator reads the rated load for fully extended outriggers. It cannot be used when the outriggers are at the intermediate or minimum position

Use the scale band according to the number of booms extended.

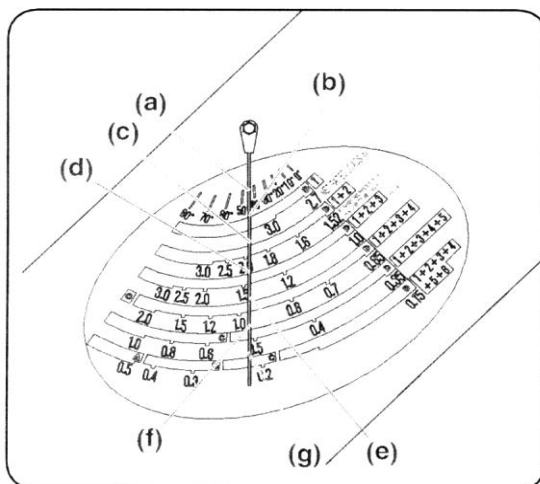

The example shown is for the URW 506

**Example**

The indicator needle reads 45° at point (a) on the boom angle scale.

Maximum load that can be lifted (rated load) reads:

- Boom 1 2,7t at (b)
- Boom 2 2,0t at (c)
- Boom 3 1,5t at (d)
- Boom 4 1,0t at (e)
- Boom 5 0,53t at (f)
- Boom 6 0,23t at (g)



When any boom section is partially extended, treat it as a fully extended section.

- When boom section 2 is extended from section 1 take the rated load for 1+2 (2,0t in the above example)
- When boom section 3 is extended from section 2 take the rated load for 1+2+3 (1,5t in the above example)

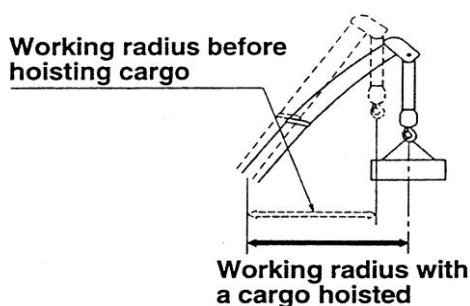

Since the working radius increases due to boom deflection when a load starts to be lifted, set the boom angle slightly inside the desired value



**How to obtain the correct hoisting capacity when the outriggers are extended to other than maximum.**

As a general rule the outriggers should always be extended to their maximum.

Otherwise obtain the capacity as shown below.

- Find the working radius.
- The rated load is found by using the 'outriggers extended to halfway (intermediate)' or outriggers extended to minimum' row according to the number of boom sections extended.
- Operating with a working radius of 6.5m with boom sections **1+2** and the outriggers extended to halfway (intermediate) the capacity is 1,2t
- Operating with a working radius of 6.0m with boom sections **1+2+3+4** and outriggers extended to minimum the capacity is 1.1t

Boom Extension: 1, 1+2, 1+2+3

Working Radius (m)		3,0	3,4	4,0	4,5	5,0	5,5	6,0	6,5	7,0	7,5	8,53
Rated Load (t)	Outriggers extended to Maximum	3,0	3,0	2,4	2,1	1,85	1,7	1,55	1,4	1,3	1,2	1,0
	Outriggers extended to Intermediate	3,0	3,0	2,4	2,1	1,85	1,7	1,4	1,2	1,05	0,85	0,62
	Outriggers extended to Minimum	3,0	3,0	2,4	2,0	1,65	1,35	1,1	0,9	0,75	0,6	0,45

Boom Extension: 1+2+3+4

Working Radius (m)		4,0	4,5	5,0	5,5	6,0	7,0	8,0	9,0	10,0	10,86
Rated Load (t)	Outriggers extended to Maximum	2,0	1,8	1,6	1,45	1,3	1,1	0,95	0,85	0,75	0,64
	Outriggers extended to Intermediate	2,0	1,8	1,6	1,45	1,3	1,05	0,7	0,6	0,45	0,39
	Outriggers extended to Minimum	2,0	1,8	1,6	1,35	1,1	0,75	0,5	0,4	0,3	0,25

This example is for the URW 506C, however the principle is the same for the URW 376 / 706C



The load indicator on boom cannot be used with the outriggers set at other than maximum



When the outriggers are set to unequal extensions the rated load is determined by using the shortest extension



**Important Note:** The Safe Load Indicator will automatically select the relevant duty chart according to the outrigger extension as follows:

**Maximum: Duty 3**  
**Intermediate: Duty 2**  
**Minimum: Duty 1**



d. **Warning Horn**

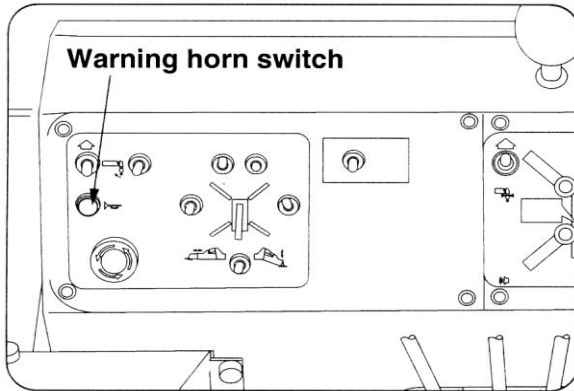

Press the warning horn button to warn people that an operation such as slewing is about to commence

e. **Hook Safety Catch**

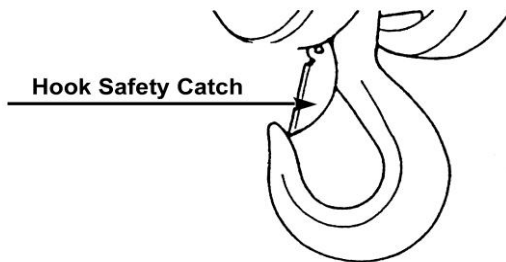

**It is essential that all lifting accessories are seated correctly on the hook and the safety catch is closed fully**

The hook safety catch is used to retain lifting accessories in the correct place on the hook

f. **Automatic Wire Rope Stop**

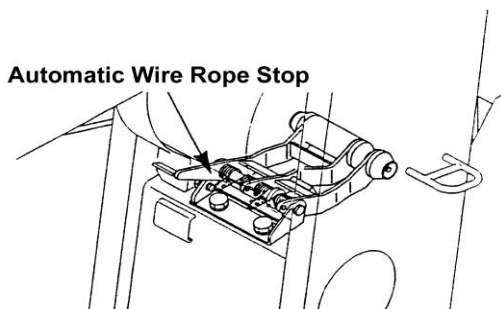

This device prevents the wire rope on the drum from slackening when the hook makes an abrupt stop or when the hook/load is lowered to the ground.

In addition it stops the drum unwinding when the rope approaches only having 3 turns left on the drum, therefore preventing it unwinding fully



**Intentionally Blank**



## 10 CARRIER OPERATIONS

### a. Designation and position of control levers

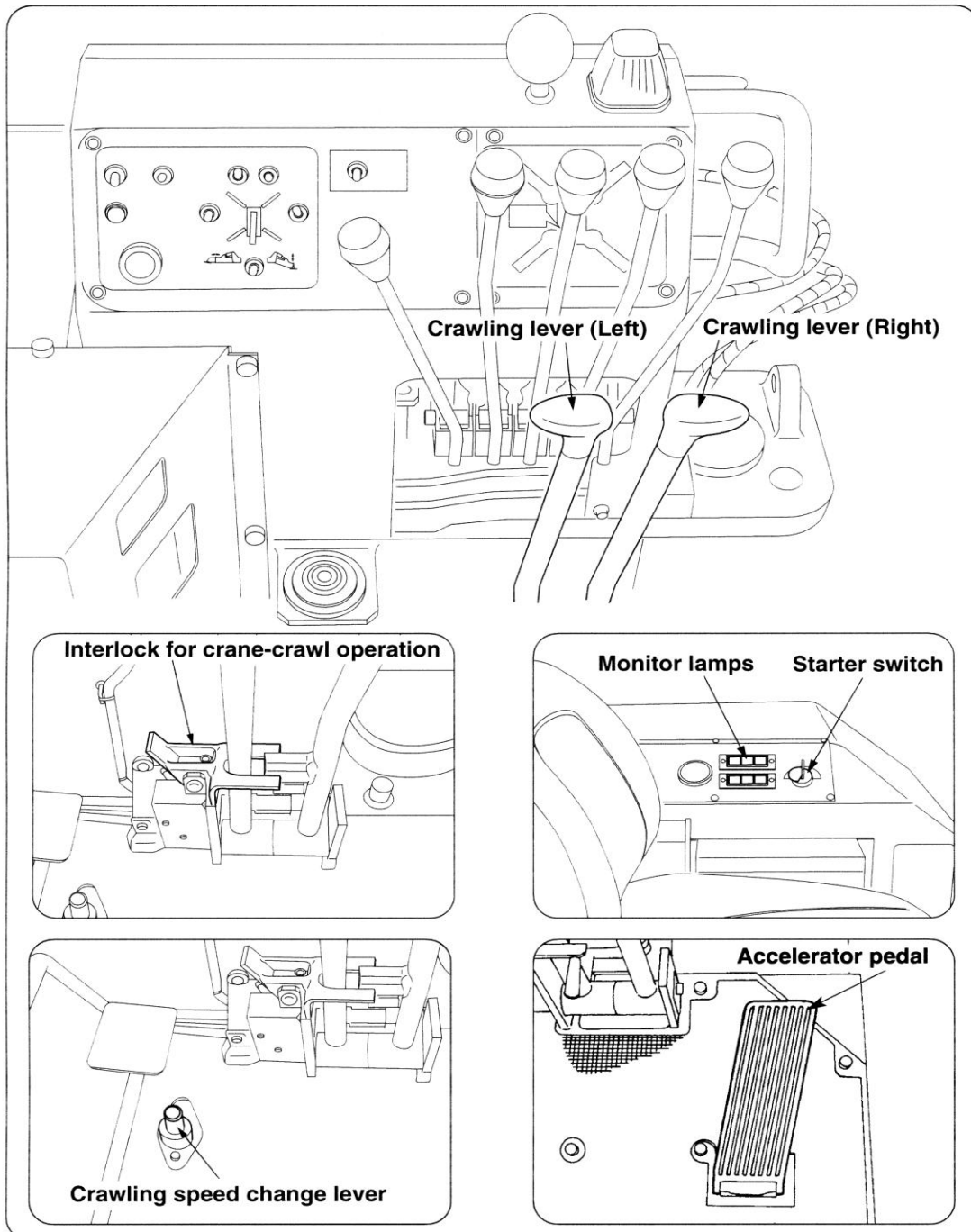

b. **Before Use**



**DO NOT** Start or run the engine in confined or closed spaces. Ensure there is adequate natural ventilation, if not, forced ventilation **MUST** be provided. Danger of death from toxic and suffocating fumes is **EXTREMELY** high.



**DO NOT** Start the engine from outside the operators seat. Danger is from inadvertent movement of the vehicle.



**DO NOT** Start the engine until you have cordoned the area and confirmed there are no non-essential personnel nearby. Danger is from inadvertent movement of the boom or hook



Heavy duty operation of the crane whilst new may lead to poor performance and a dramatically reduced in-service life. Avoid abrupt starting, acceleration and continuous heavy operation for the first 100 hours

- Press the 'crane-crawl' interlock pedal with your foot to free the controls and engage the crawl functions

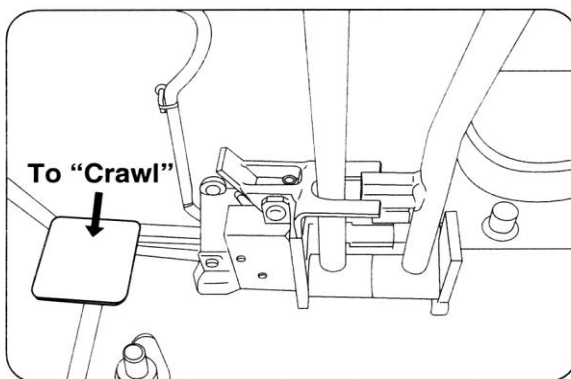

Ensure both crawling levers are in the neutral position

**Description of the warning lamps:**

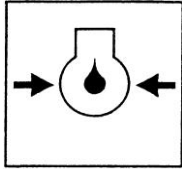

**Engine oil pressure light:** This illuminates when the engine oil pressure drops below its preset limit. All crane work **MUST** stop immediately. Turn off the engine and investigate the cause.

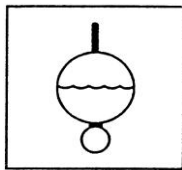

**Engine water temperature light:** This light illuminates when the circulating engine cooling water has risen above a preset temperature. If the light illuminates during operation crane work **MUST** stop immediately. Idle the engine until the light goes out. Turn of the engine and wait until the system is cool enough before investigating.



**Air cleaner light:** This illuminates when the air cleaner becomes clogged. If allowed to continue this could put undue strain on the engine which may cause it fail. If it illuminates during operation the all crane work **MUST** stop. Remove the clogged element and clean it or replace it

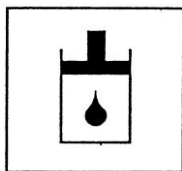

**Hydraulic oil temperature light:** This light illuminates when the hydraulic oil temperature has risen above the predetermined limit. If this lights during operations all crane work **MUST** stop immediately. Allow the engine to idle until the lamp goes out. Stop the engine and allow the oil to cool until it is safe enough to investigate.

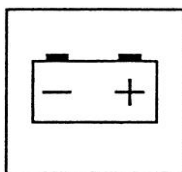

**Alternator warning lamp:** This lights when there is a fault with the alternator itself or the battery charging system. If this lights during operations all crane work **MUST** stop immediately. Stop the engine and allow it to cool. When cool check the fan belt for tightness. Check the wiring to the alternator and relays for broken or loose connections or poor contact.



**Pre-heater light:** This light illuminates when the starter switch is turned to the 'HEAT' position. It indicates that power is being applied to the pre-heater glow plugs in the combustion chamber of the engine. This is an aid to starting the engine in cold conditions.

Hold the starter switch in the 'HEAT' position until the light goes out (approximately 15 seconds) and the engine can be started as normal.

c. **Operation**



**DO NOT** use an auxiliary starter fluid such as Cold Start as there is a risk of explosion



Continuous running of the starter motor will discharge the battery and damage the motor. Do not run the starter for more than 20 seconds at a time.

If it does not start wait at least 1 minute before retrying

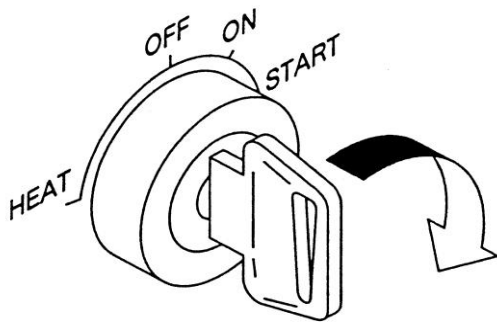

i. ***Starting the engine under normal conditions***

- Insert the key and turn it to the 'ON' position
- Depress the accelerator pedal about 1/3 of its stroke
- Turn the key to 'START' position
- Release the key after the engine has started running.

ii. ***Starting the engine in cold weather***

- Insert the key, turn to the 'HEAT' position and hold it there until the pre-heater warning lamp goes out (approximately 15 seconds)
- Depress the accelerator pedal fully and turn the key to 'START'
- Release the key
- Adjust the accelerator to the slowest speed where the engine runs smoothly
- Once the engine is running smoothly ease up the accelerator until the engine is idling evenly

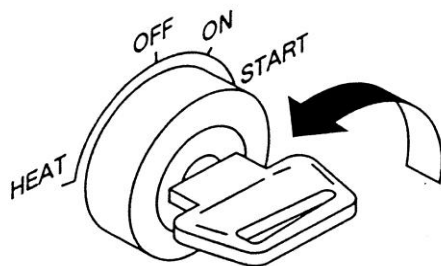



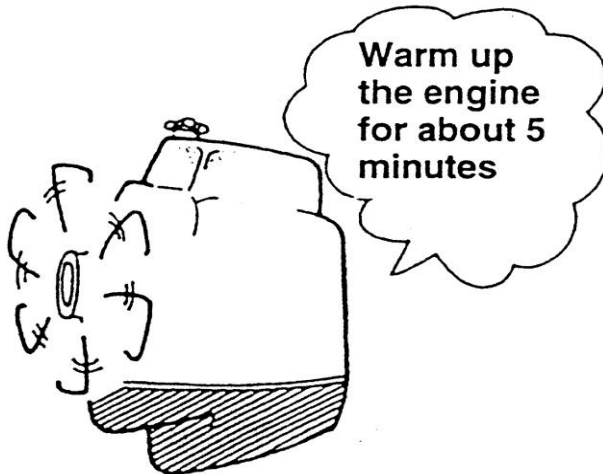

**iii. After the engine has started**

- Ensure that none of the warning lamps illuminate after the engine has started. If so, stop the engine and investigate.
- After idling the engine for approximately 5 minutes to warm up, move each lever with the accelerator depressed halfway to warm up the hydraulic system. This allows the hydraulic oil to circulate and lubricate the system but also allows the engine to warm up to operating temperature gradually.
- Check the engine for unusual vibration, noise, odour and colour of the exhaust gas. If there are any doubts contact UNIC Cranes Europe Ltd.
- Check the hydraulic equipment and engine for oil leakage



d. **Crawling Operations**



**DO NOT** drive the crane until the area around the crane has been checked for persons or obstacles. Use assistance.



**DO NOT** attempt to move the vehicle until the boom is fully retracted and stowed correctly



**DO NOT** attempt to move the vehicle until the outriggers are stowed and locked correctly



**DO NOT** park the vehicle over areas that may catch fire due to the heat of the exhaust, e.g. dry grass, straw, cloths, etc.



**Crawl as slowly as possible** when turning or crawling on rough terrain. Pay particular attention when turning left as the stowed boom creates a blind spot



**Stop the engine, remove the key and remove your foot from the 'crane-crawl' interlock pedal.** If you are leaving the vehicle for a long period chock the tracks. If you are parked on a public road, barriers and flashing lights must be used to warn other road users of its presence



**When operating in, or fording water ensure you do not exceed the maximum permissible depth, i.e. no higher than the track tensioning grease nipple.**

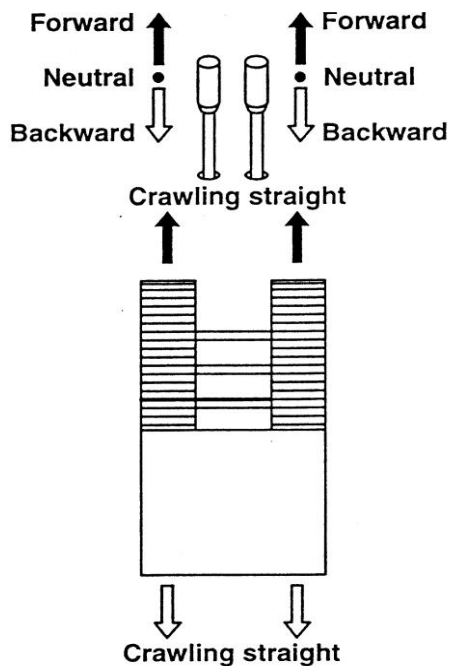

**i. Crawling in forward and reverse**

- Ensure that the 'crane-crawl' interlock pedal is depressed
- To crawl forward: sit in the drivers seat and push both levers away from you (forwards). They should both travel the same distance to ensure you do not crawl in a curve.
- To crawl in reverse: sit in the drivers seat and pull both levers toward you.

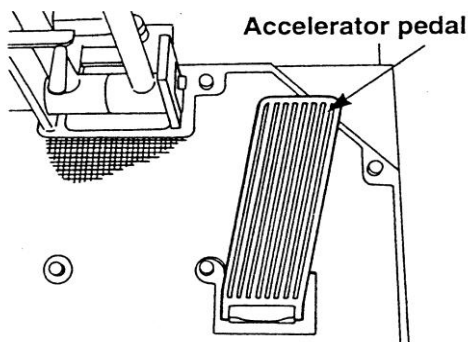

When crawling, fine speed adjustment is carried out by moving the levers away from neutral (faster) or towards neutral (slower).

Coarse speed adjustment is by way of depressing the accelerator with the levers in the desired direction.

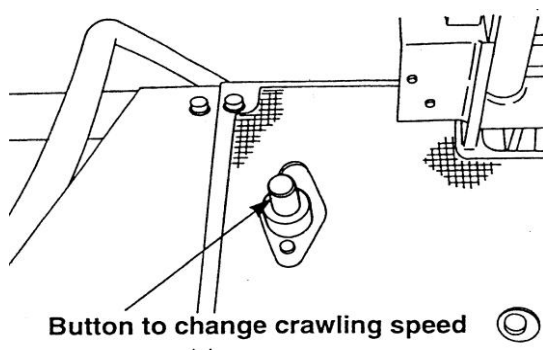

There are two speed ranges available to the driver. The normal range is low speed (1,7km/h). To access the high range (3,0km/h) push the floor button down with the foot.

This **MUST NOT** be used when ascending or descending slopes or on uneven terrain where the crawling resistance is greater or turning

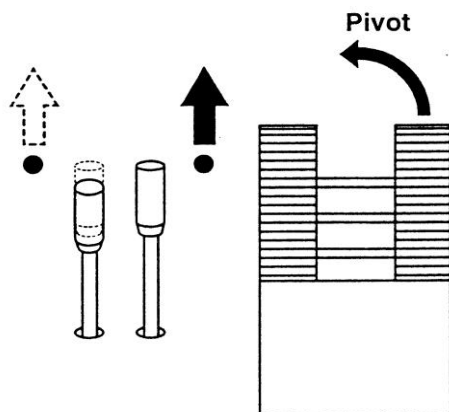

**ii. Making a turn**

Making a turn while the crane is crawling

- When moving forward: moving the left hand lever to neutral causes the crane to turn to the left and vice versa.
- When moving backwards: moving the left hand lever to neutral causes the crane to turn to the right and vice versa.

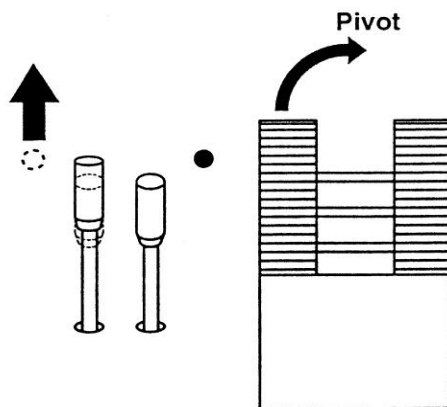

Making a turn while the crane is stationary

- Pushing the left hand lever away from you causes the crane to turn right and vice versa.
- Pulling the left hand lever towards you causes the crane to turn left and vice versa

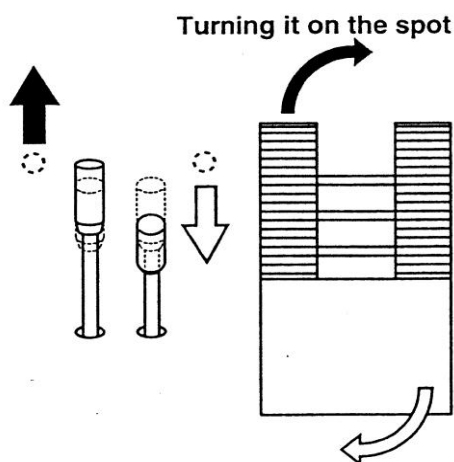

Making a turn on the spot

- Pushing the left hand lever away from you while pulling the right hand lever towards you at the same time causes the crane to spin on its own centre axis to the right (or clockwise) and vice versa

### How to Park Crane.

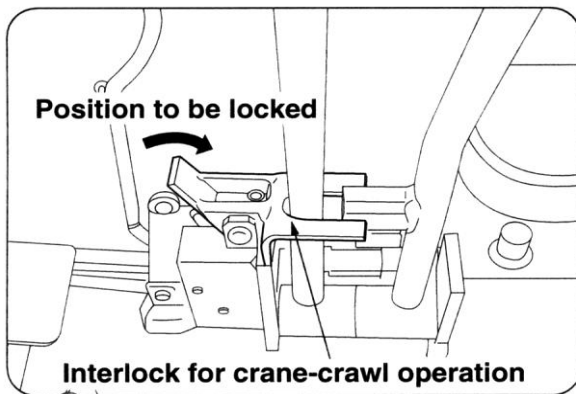

- Release the accelerator to allow the engine to idle.
- Ensure both crawling levers are in the neutral position and release the crane-crawl interlock pedal to lock the crawling levers.

### Allowable Depth of Water

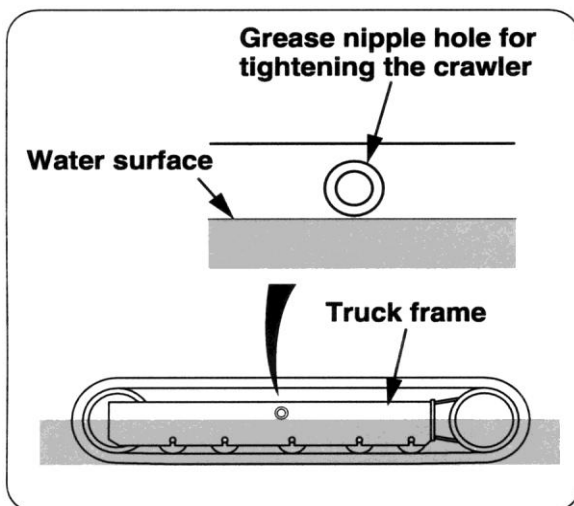

- When wading the crane ensure the water level is below the track tensioning grease nipple.



**Intentionally Blank**



## 11. CRANE OPERATIONS

### a. Description and location of the control levers

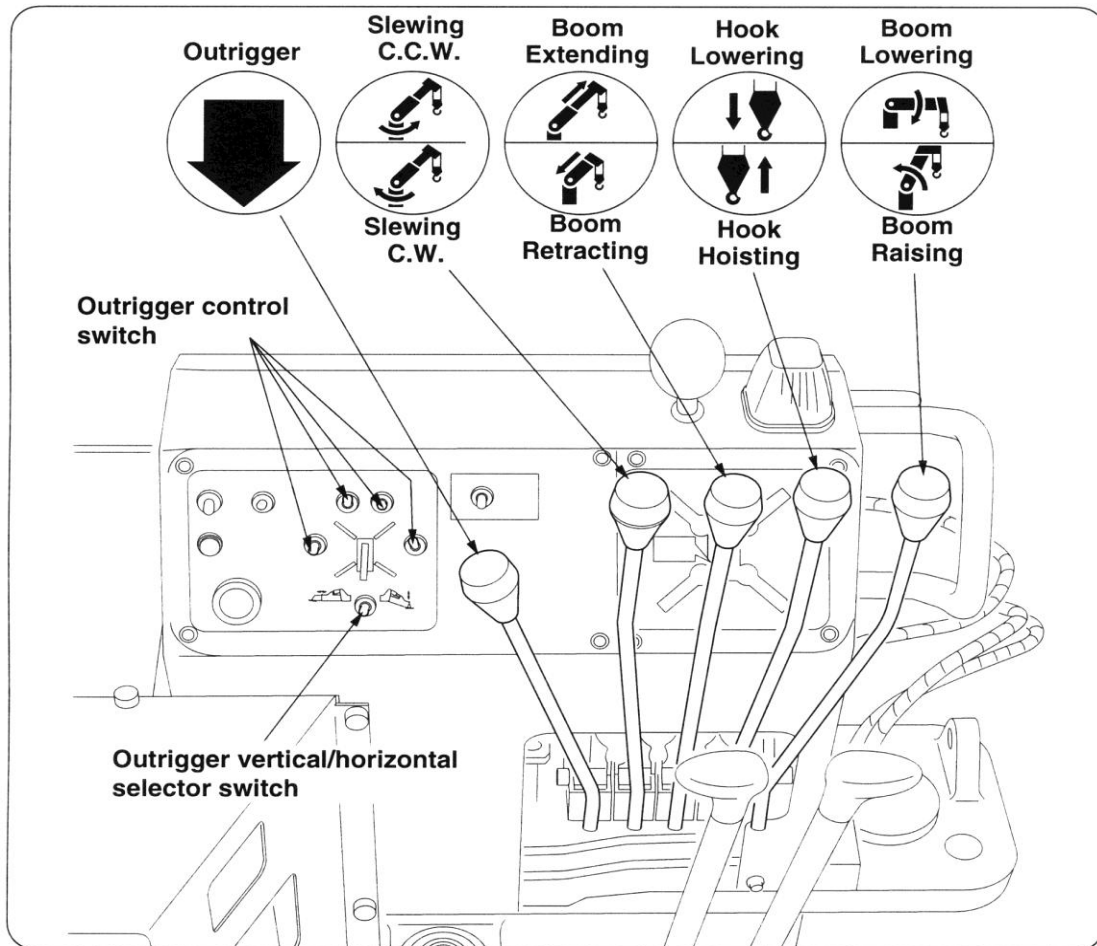

### b. Before operation



**DO NOT** allow anyone to stand near the hook when it is released from stowage position. As the hook may swing when released, anyone standing close, may be struck by the hook.



During cold weather always allow the hydraulic pump to run for 5 minutes after start up. This allows the hydraulic oil to reach operating temperature. This ensures smooth, consistent, predictable and **SAFE** operation of the crane. Also, as the viscosity of the oil is higher during cold weather, high speed running of the pump will lead to incorrect circulation of the oil and almost certainly lead to pump failure.

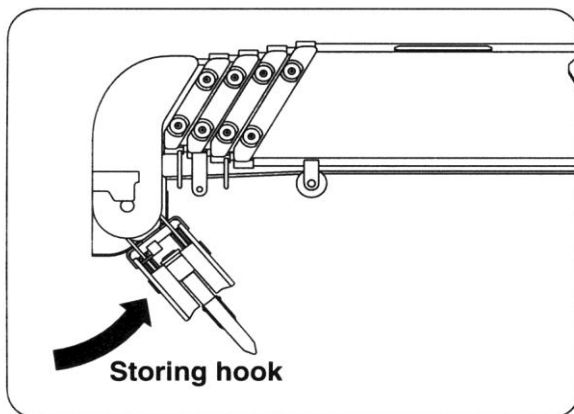
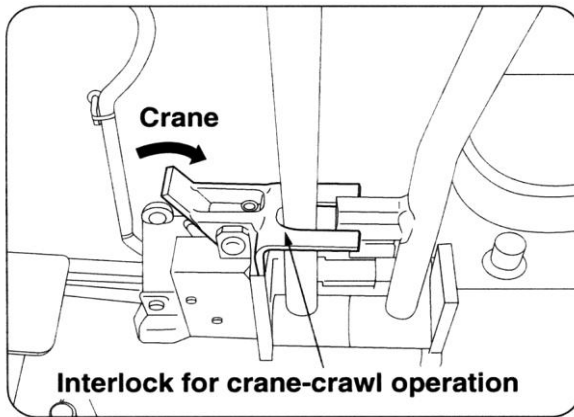

- Make sure that each of the outrigger control levers is in its neutral position.
- Start the engine.
- Release the 'crane-crawl' interlock pedal.
- If the front outriggers are swung out ready to set up, the overwind alarm buzzer should sound. (If it does not, investigate before continuing).
- Use the 'Hoisting-Lowering Hook' lever to release the hook from its auto-stow position.
- Lower the hook until the overwind alarm goes off.
- The crane is now ready to operate.

**Crane Pre-Use Inspection**



**DO NOT** operate the crane while system diagnosis is in progress. If the crane is operated during system diagnosis the voice warning system will voice “Service Remote Control, Service Remote Control” and the crane will become inoperable. To reset, restart the engine



If the mode indicator lamp fails to light or the voice warning system voices “Service Remote Control, Service Remote Control” even though the crane has not been operated, refer to Chapter 9 (b) (ii) ‘Reset if automatic overwind is faulty’, store the crane and request your nearest authorised UNIC dealer for inspection and repair

Before use ensure that the control box is functioning correctly. The control box is energised when starting the engine and will show 8.8 on the mode indicator lamp.

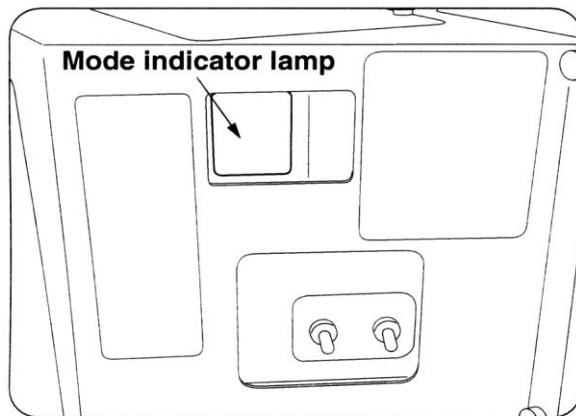

- The mode indicator lamp will show 8.8 for approximately 2 seconds when extracting the outrigger set pins from the stowed position and again when reinserting them at their operational position.

During the system diagnosis the following items will be checked

- 1 Checking if the electronic circuitry of the control box is functioning
- 2 Checking the manual control lever is in the neutral position
- 3 If everything is functioning normally the number 01 will be indicated
- 4 Refer to Chapter 18 for more detail



**Outrigger set-up procedures**



Any operation of the crane without the outriggers set-up in accordance with these instructions is **STRICTLY PROHIBITED**.



**DO NOT** set-up the outriggers on uneven or soft ground, nor where the outrigger would be on a slope. If the surface is soft, uneven or sloped always ensure that a support such as a steel road plate or adequate timber dunnage is placed under the outrigger foot. This must stop the outrigger foot from moving, sliding or sinking under load. If this is not done it could lead to reduced rated load and/or tipping of the crane.



**ALWAYS** ensure the locking pin is in place when storing the outriggers to stop the outrigger inadvertently rotating. Failure to use the locking pin when stowing may lead to the leg rotating during crawling and creating a striking hazard.



**DO NOT** place your foot or any other body part under the outrigger when extending. This is a severe crushing hazard.



**DO NOT** put fingers near the inner box sections when retracting, this is a severe nip hazard. Similarly, when stowing the outriggers a potential nip hazard exists between the outrigger/carrier or outrigger/outrigger. Therefore always ensure you use both hands on the handles provided.



**ALWAYS** extend the inner box section of the outrigger first before extending the upper cylinder. Retract in reverse order.



**ALWAYS** set-up the crane on firm, level and uniform ground and then raise the carrier until the bottom track is approximately 50mm above the ground.

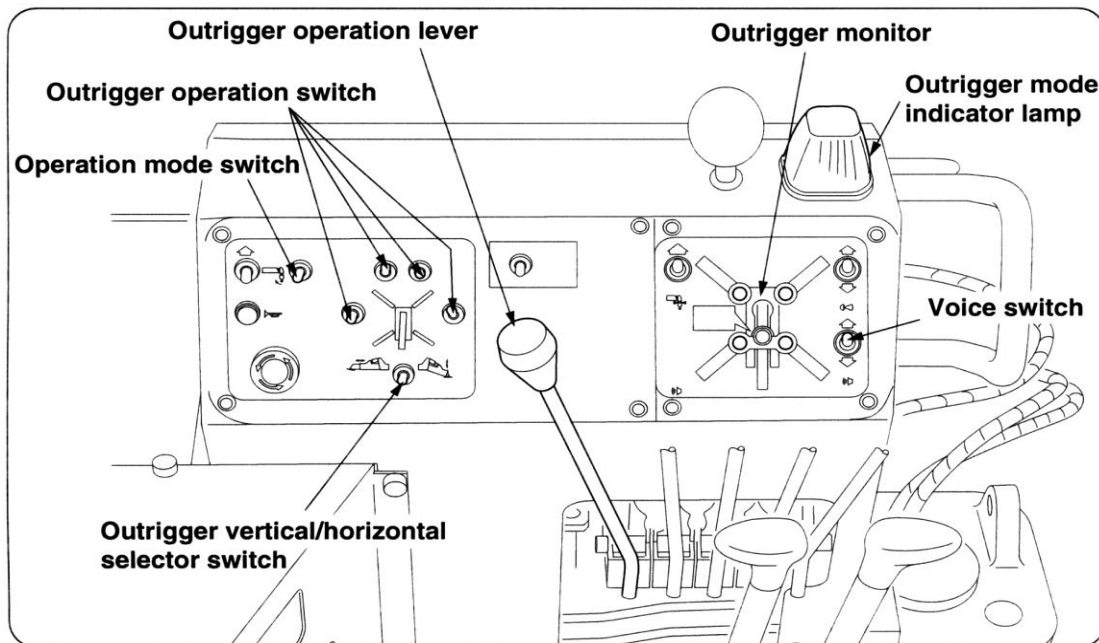

There are 4 switches for controlling outrigger extension and retraction, these are numbered to match the outriggers

Ensure the voice warning switch is set to ON

Remove the outrigger set pins and rotate the outriggers to their operational position. Insert the set pins a voice message "Remote Control" is heard and the four lights on the Outrigger Monitor Panel will light. Outriggers cannot be operated until these lights are lit.

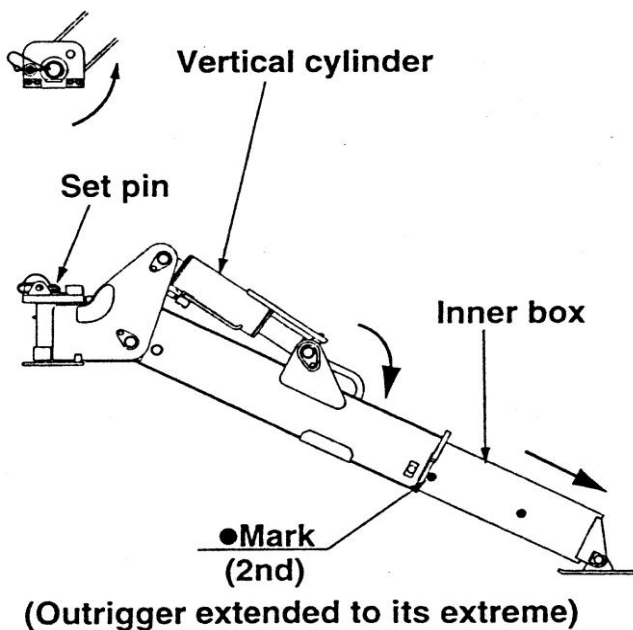

Switch the operation mode to OUTRIGGER, the voice message 'Change Control Mode' will be heard and the outrigger mode indicator lamp will light. If it fails to light reset the mode switch.

Turn the outrigger vertical/horizontal selector to HORIZONTAL. The voice message 'Change Control Mode' is heard. **Note:** the message will not be heard if the mode is already selected.

Select all outrigger operation switches to EXTEND and pull outrigger operation lever to extend the inner box.

Turn the outrigger vertical/horizontal selector to VERTICAL. The voice message 'Change Control Mode' is heard.

Select each outrigger individually and pull the outrigger operation lever to extend the vertical cylinder until the outrigger is JUST touching the ground.



When all four outriggers are extended to the ground select NO MORE than two outriggers and extend or retract as necessary to raise the crane approximately 50mm from the ground.

Extend or retract as necessary (NO MORE than two outriggers at a time) to level the crane using the level on the drivers position footplate.

**d. Operating boom for derricking (raising and lowering)**



**DO NOT** cause the crane to start or stop abruptly this may cause excessive shock to the crane which could cause the load to be lost, the crane tipping over or at least damage to the crane.



**DO NOT FORGET**, when lowering the boom with a load attached the working radius increases which decreases the capacity. Check the readings on the load indicator to confirm the safety margin before lowering commences.



The longer the boom is extended the faster the load is raised and lowered by a boom derricking operation. The controls are fully proportional, i.e. the further you push or pull the faster it goes. Operate the controls slowly and smoothly.

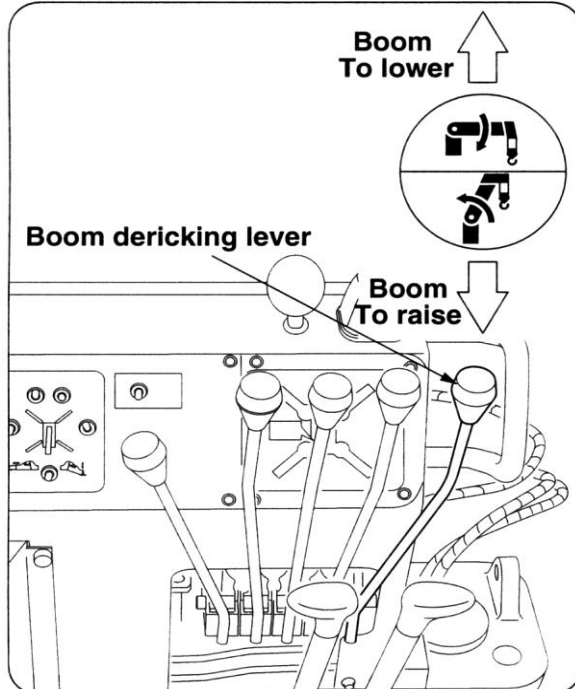

**To operate boom derricking:**

- Pull the lever to 'RAISE' to lift the cargo.
- Push the lever towards 'LOWER' to lower the load.
- To stop either operation return the lever to the neutral position.
- **DO NOT** release the lever suddenly except in an emergency situation. Always return it to neutral under control.
- Further control of the derricking speed can be achieved by using the derricking lever together with engine speed adjustment by the accelerator pedal.



e. Winding the hook up and down



**DO NOT** allow the hook to be overwound. Allowing the hook to bind against the top of the boom can cause serious damage to the wire rope and the sheaves, which may cause the load to be released

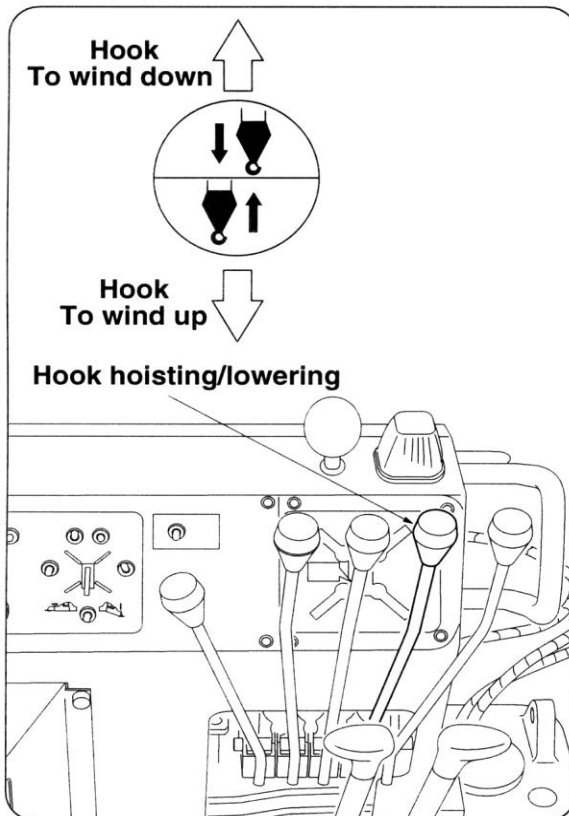

**To wind up and down:**

- Pull the lever to 'UP' to hoist the cargo.
- Push the lever towards 'DOWN' to lower the load.
- To stop either operation return the lever to the neutral position.
- **DO NOT** release the lever suddenly except in an emergency situation. Always return it to neutral under control.
- Further control of the hoisting speed can be achieved by using the rope winch lever together with engine speed adjustment by the accelerator pedal.



Paying out more rope once the load or hook has reached the ground causes the rope to unwind off the drum. If the rope is taken up it will be wound on irregularly. This will cause the top layers to put undue pressure on the layers below. This will damage the rope leading to a dangerous condition and seriously shorten the life of the rope.

If the rope does unwind off the drum, hoist the rope slowly and manually feed the rope onto the drum ensuring it is tightly and evenly wound.



When unwinding rope further than ground level, such as over building edges or into excavations or underground workings, ensure that at least 3 turns of rope are left on the drum.



If the hydraulic oil temperature exceeds 80°C all crane operations must cease immediately until the oil has reached its normal operating temperature again. The oil is prone to overheating when the hoist and lower is repeatedly operated, particularly with long lifts.

f. Telescoping the boom



**DO NOT** operate without the overwind alarm operating correctly. When the boom is extended the hook raises. If the overwind alarm is not working the hook will bind against the top of the boom causing serious damage to the wire rope and the sheaves, which may cause the load to be released

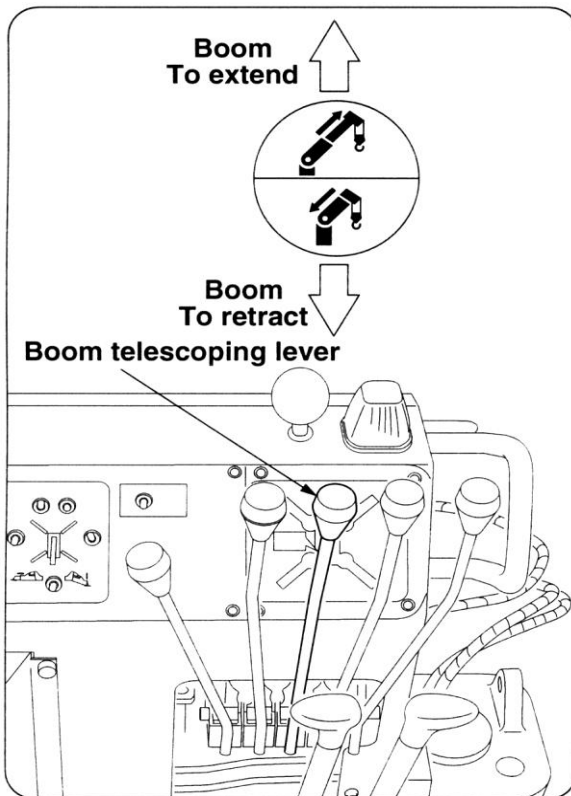

**To operate boom extension/retraction:**

- Push the lever to 'EXTend' to extend the boom.
- Pull the lever towards 'RETract' to retract the boom.
- To stop either operation return the lever to the neutral position.
- **DO NOT** release the lever suddenly except in an emergency situation. Always return it to neutral under control.
- Further control of the boom extension/retraction speed can be achieved by using the boom extension/retraction lever together with engine speed adjustment by the accelerator pedal.

**Sequence of boom extension**

The boom extends from the outer box sections.

**Sequence of boom retraction**

The boom retracts from the top section down.

**(5-section boom)**

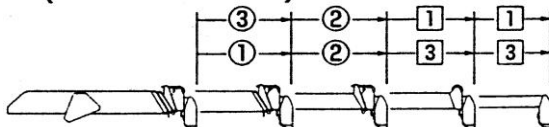

**(6-section boom)**

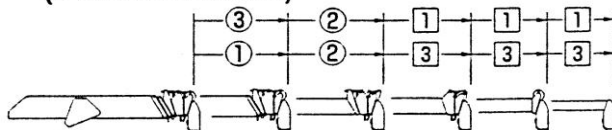

Sections of the boom shown in the boxes show that they are telescoping simultaneously

When the viscosity of the oil is high due to a cold environment this can affect the speed and control of the boom extension. To warm the oil, carry out a full extension and retraction prior to commencing any lifting.

g. Slewing the boom



DO NOT race the engine during slewing operations



DO NOT make abrupt starts and stops. This will cause the load to swing and may cause personal or material damage by striking someone or something. It may even lead to tipping of the crane. Always operate controls slowly and smoothly.



The longer the boom length and the smaller the derricking angle, the faster the load will move during slewing. The faster the load moves, the greater the inertia, the harder it is to stop the load and the more violently it will swing. This will cause a serious risk to all operating near the crane. Always slew at a speed consistent with the configuration of the crane and load.

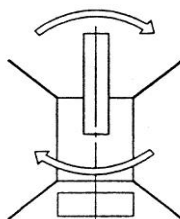
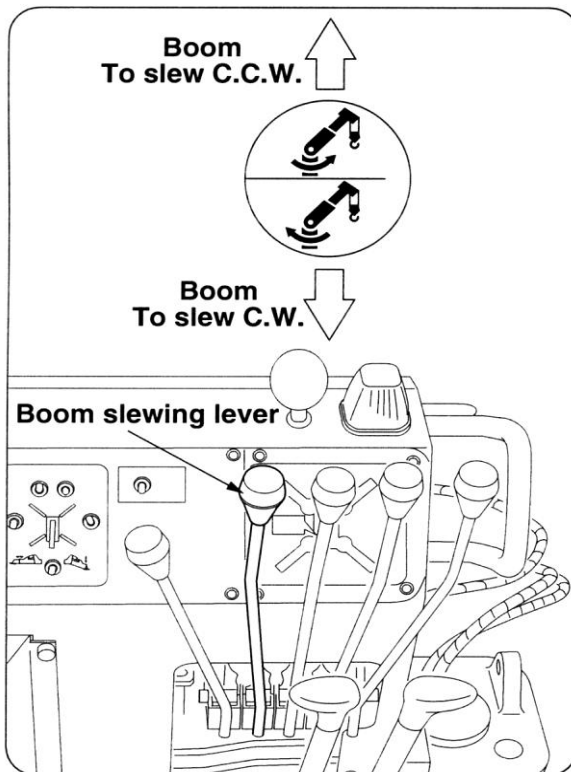

Slew to the right (C.W.)

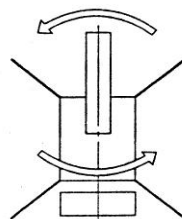

Slew to the left (C.C.W.)

**To slew the crane:**

- Pull the lever to to slew the boom clockwise.
- Push the lever towards to slew the boom anti-clockwise.
- To stop either operation return the lever to the neutral position.
- **DO NOT release the lever suddenly except in an emergency situation. Always return it to neutral under control.**
- Further control of the slewing speed can be achieved by using the slewing lever together with engine speed adjustment by the accelerator pedal. **However, read the warnings!!**
- 'Slew right' means slewing the boom in the same direction as the hands of a clock would move (if the crane was seen from above) i.e. 'clockwise'.
- 'Slew left' means slewing the boom in the opposite direction to the hands of a clock (if the crane was seen from above) i.e. 'anti-clockwise' or 'counter-clockwise'.

**h. Storing the boom**

**a. URW 376/506**



**ALWAYS** ensure that the boom is stored by slewing anti-clockwise. Slewing clockwise will create a crush hazard to the driver between the boom and the engine compartment.

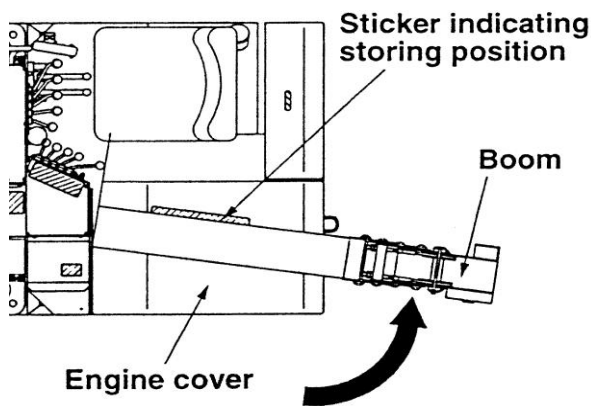

- Retract the boom
- Lower the boom until it stops
- Slew the boom in a anti-clockwise direction to the rear of the engine compartment
- Align the boom with the sticker on the engine cover. The boom will stop automatically when it activates the sensor
- Store the hook

**c. URW 706**

	<p>Retract the boom and slew until the two marks on the slew ring line up.</p> <p>Lower the boom</p> <p>Stow the hook</p>
--	---

i. Stowing the hook



**DO NOT** stow the hook until all boom sections have been retracted and the boom has been stowed correctly

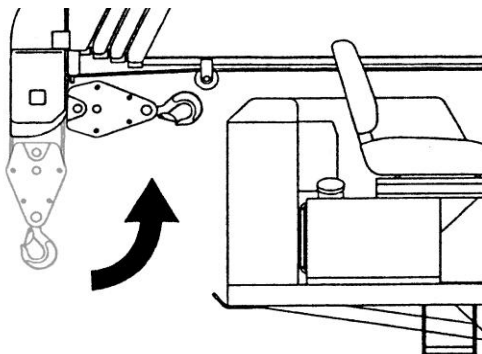
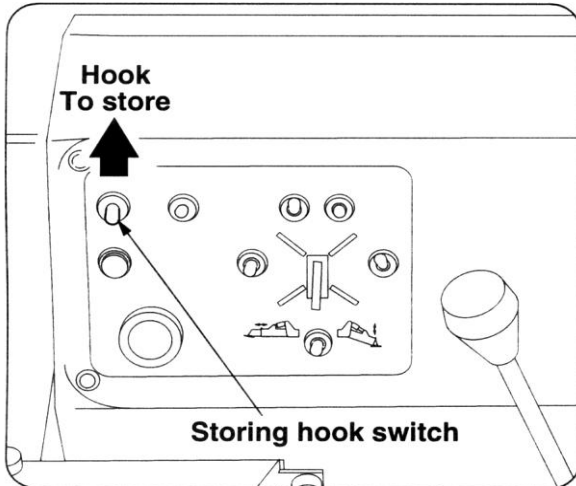

- Wind up the hook with the hook up/down control until the overwind alarm sounds
- Stop winding up
- Set and hold the hook storing switch to store
- Use the hook storage lever to continue winding up the hook
- **It is vitally important that you watch the hook continuously during this operation**
- When the hook reaches the bottom of the boom it will rotate rearwards into its stowage position
- When it achieves its stowage position release the hook storage lever immediately, otherwise the rope may be damaged

j. Storing the outriggers



**DO NOT** store outriggers before boom has been stored.

**DO NOT** retract the inner boxes until the vertical cylinders have been retracted fully



When storing the outriggers **ALWAYS** ensure the locking pin is in place to stop the outrigger inadvertently rotating. Failure to use the locking pin when stowing may lead to the leg rotating during crawling and creating a striking hazard.

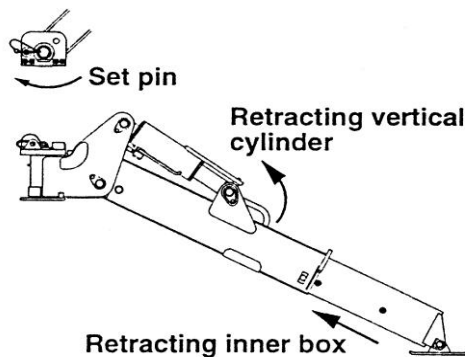

- Turn the operation mode switch to OUTRIGGER. The voice message 'Change Control Mode' is heard and the outrigger mode lamp is lit.
- Set the vertical/horizontal selector switch to VERTICAL. The voice message 'Change Control Mode' is heard.
- Set outrigger operation switches (NO MORE than two at a time) to STORE and pull outrigger operation lever to fully retract the vertical cylinders.
- Repeat for remaining outriggers.
- Set the vertical/horizontal selector switch to HORIZONTAL. The voice message 'Change Control Mode' is heard.
- Set all four outrigger operation switches to STORE and pull outrigger operation lever to fully retract the inner boxes.
- Remove the locking pins and manually rotate the outriggers to their storage position
- Re-insert the locking pins, ensuring that they are securely in place
- Return all outrigger control levers to their neutral position.
- Turn the voice switch to OFF





**k. URW 706 Extension Jib**

**a. Fitting and using the jib**

Overall view of extension jib.

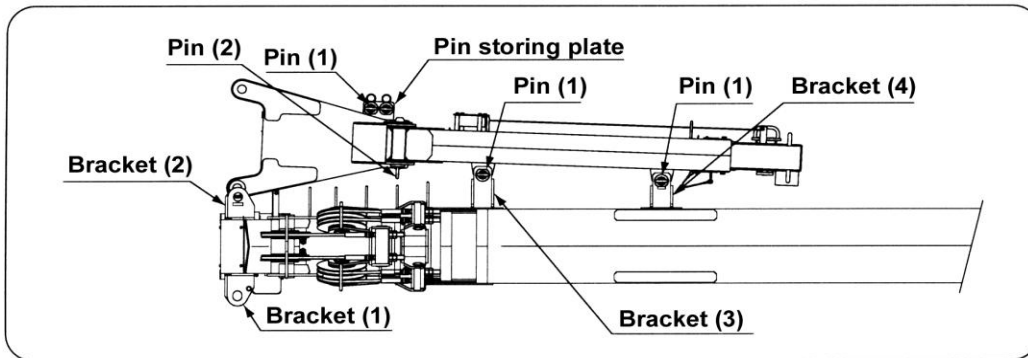

Must be used with single fall block only

Retract the boom fully

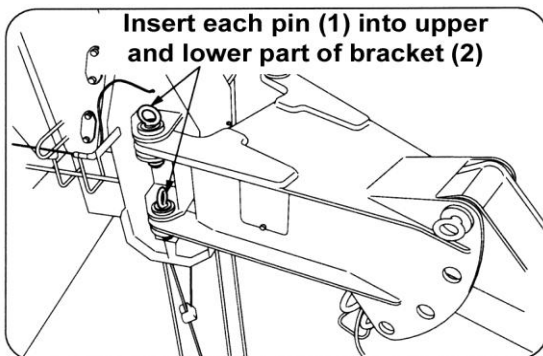

Extract pin (1) from bracket (4). Rotate extension with pin (1) located into bracket (3)

Insert pin (1) extracted from bracket (4) and pin (1) from storing plate into bracket (2) at top and bottom positions.

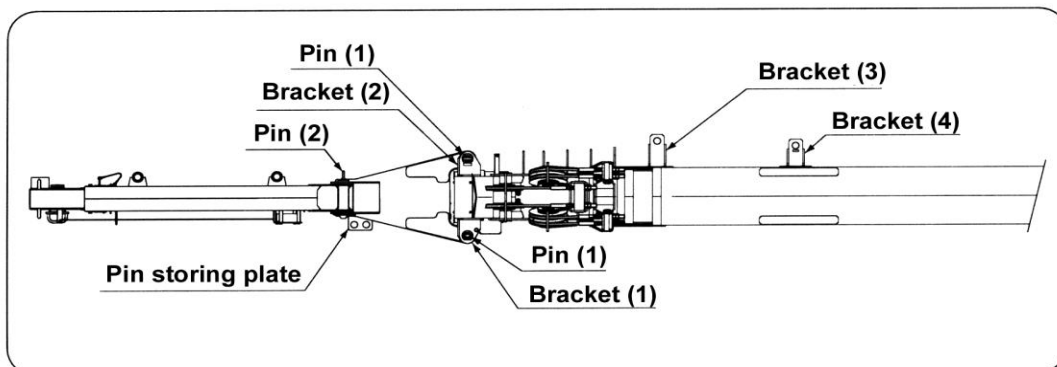

Extract the pin (1) in bracket (3) and rotate the jib.

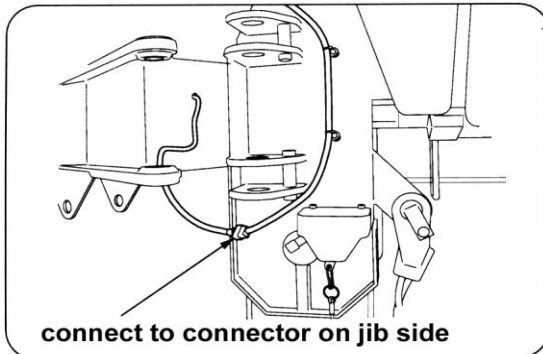

Disconnect the overwinding alarm detector wire harness and connect to the connector on the extension jib.

Insert the removed connector from the extension jib into the overwinding alarm detector to prevent the ingress of moisture.

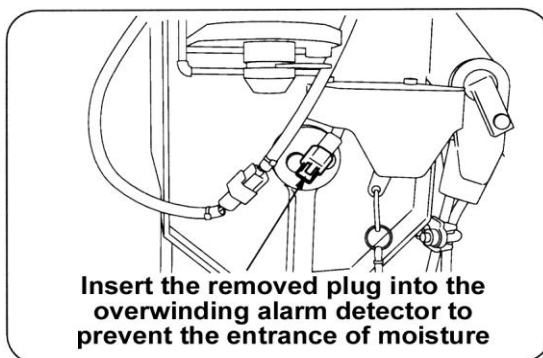

Insert the pins removed from bracket (3) and the pin (1) from the storing plate into bracket (1) at top and bottom positions.

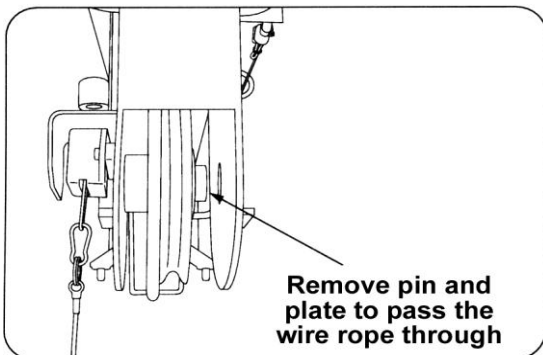

The wire rope can be placed onto the extension jib pulley without removing the hook from the rope.

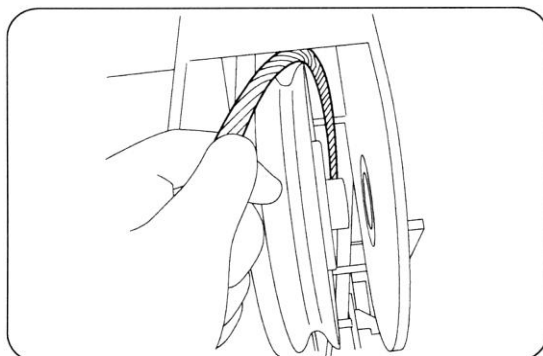

Pass wire rope through the wire guide at lower face of extension. Extract the pin fastening the sheave at the top and place on the pulley through the gap between the sheave and the side plate.

When extending the extension jib, extract the fixing pin to extend it manually. Be sure to insert the fixing pin after the jib has been fully extended. Ensure the retaining pin has been securely inserted.

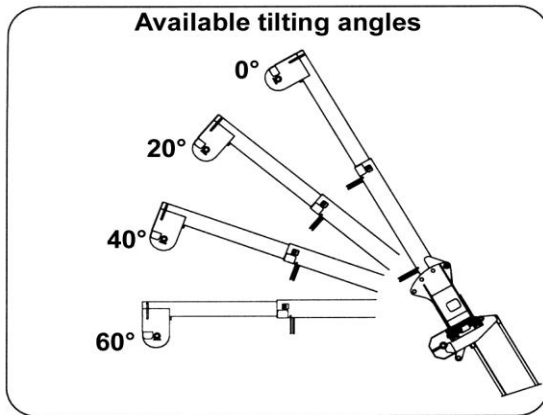

When tilting the extension jib, extract pin (2) whilst supporting the top part of extension. Insert the pin into the hole that matches the desired angle.

Since both rated load and working range vary in accordance with the angle, ensure you are operating the crane in accordance with the correct rated load chart.

**b. Storing the jib**

- i Retract both the extension jib and main booms fully.
- ii Set the extension job angle to 0°
- iii Remove the rope from the pulley at the top of the jib
- iv Remove pins from bracket (1) and rotate jib
- v Disconnect the wiring harness on the boom side from the wiring harness on the jib and connect it to the overwind alarm detector. Insert the plug removed from the overwind alarm into the harness connector on the jib to prevent the ingress of moisture.
- vi Rotate the jib to bring it to its storing position and insert pin (1) from bracket (1) into bracket (3) and store the other removed pin in the pin storing plate.
- vii Extract the 2 pin (1) from bracket (2) and rotate the jib to clear the main boom.
- viii Fasten the extension jib to the main boom with pin (1) through bracket (4). Store the other pin in the pin storing plate.

**k. URW 706 Searcher Hook (optional)**

**a. How to use the searcher hook**

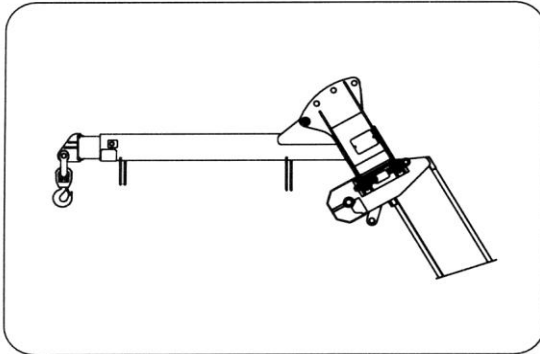

The searcher is used with the bracket and extension jib.

**b. How to change extension jib to searcher hook**

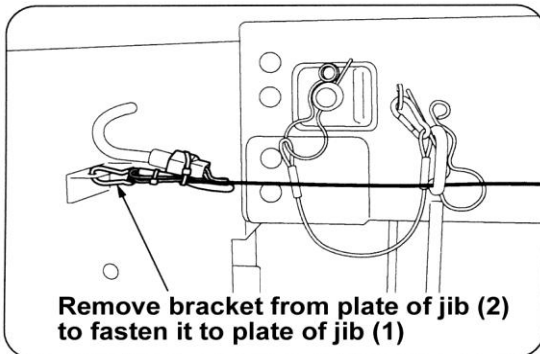

Unfasten wire rope end and fasten to the column as it will not be used.

Set up the extension jib.

Remove the overwinding alarm detector weight as this will not be used.

Connect the overwinding alarm as shown in instructions for extension jib

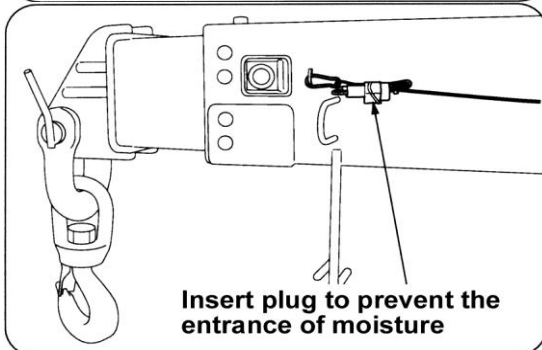

Disconnect the connect the end of the cord reel of the extension jib to attach to searcher hook.

Remove the bracket fixed to jib (2) and fasten to plate of jib (1)

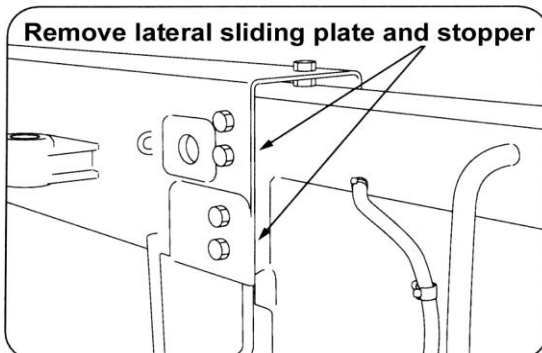

Extract the pin for retaining the extension of jib (1)  
Remove the lateral sliding plate and stopper as indicated.  
Pay attention to the bolt length when mounting the lateral sliding plate as the bolt length differs according to the fastening position

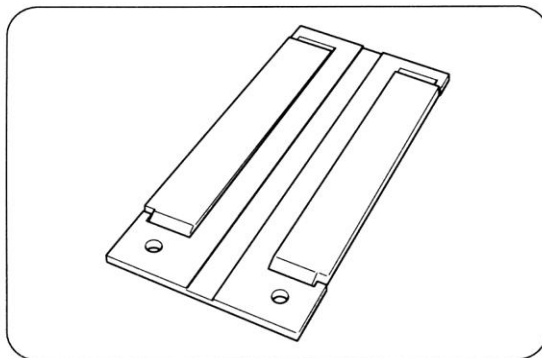
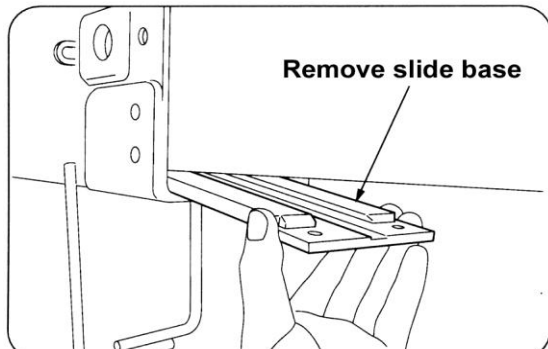

Extract jib (2) by approximately 500mm, lift up the jib and remove the slide base and sliding plate from the lower side of jib (1) and extract the jib.

Insert the searcher hook into the jib (1). Attach the lateral sliding plate and stopper as they were removed. Securely fasten the searcher hook with the attached pin and end plate

Returning the searcher hook to the extension jib is a reverse of the fitting.



**Intentionally Blank**





**12 MAINTENANCE AND INSPECTION OF CARRIER**



**DO NOT** carry out any maintenance work until power to the crane and carrier is isolated. A 'MAINTENANCE IN PROGRESS' warning signboard must be hung over the controls in the drivers position prior to any maintenance work being carried out.



All replaceable items must be replaced according to the criteria outlined in this manual. Failure to do so may cause damage to the machine and will invalidate any current warranties.



When parts need replacing (other than running spares) or anything abnormal is found contact your local UNIC dealer for, inspection, replacement or advice.

**a. Pre-use Inspection**



**ENSURE** the engine is stopped, the boom and outriggers are stowed prior to carrying out this inspection.



**NO SMOKING** during inspection or maintenance.



**DO NOT** carry out any inspection or maintenance until all working parts have cooled down sufficiently

In order to ensure that the vehicle works correctly, efficiently and safely inspect each part of the carrier in accordance with the table below.

Device	Servicing Item	Device	Servicing Item
Engine	Remaining fuel quantity/Draining water Engine oil quantity/Filling up Cooling water quantity/Filling up Fan belt tension/Adjustment Battery electrolyte solution level Unusual vibration Noise Loose bolts Broken bolts	Hydraulic Oil Tank	Oil leak, oil quantity, filling up
		Interlock for crane-crawl lever	Function
		Crawling lever	Slack, travel, excessive play
		Wheel sprocket	Loose bolts
		Rubber crawler	Cracks, damage, tension
		Frame	Bends, cracks and deformation
		Truck roller	Loose nuts, oil leakage

i. Check for engine oil level



**DO NOT** allow spilt oil to build up. It is both a fire and slip hazard.



Replace engine oil after the first 100 hours of operation or 1 month whichever is the later. It must be changed every 250 hours after that.

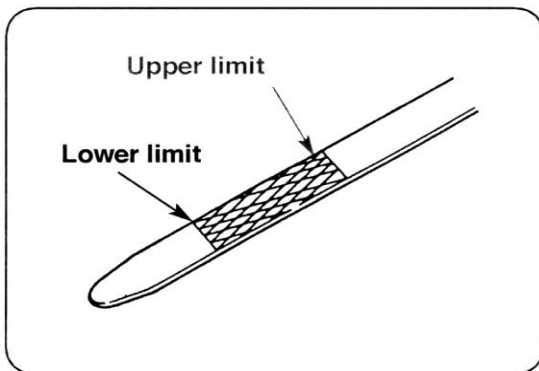
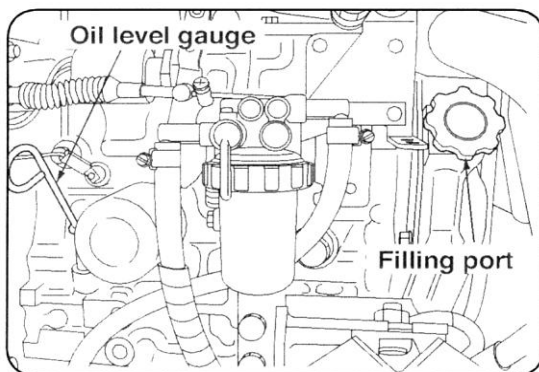

- Check the engine oil level before starting the engine.
- If the engine has previously been started allow at least 5 minutes before checking the level.
- Remove the oil level gauge (dipstick) and wipe it with a **clean** rag or paper towel.
- Re-insert the dipstick and remove it slowly and ensure the oil level is between the limits marked.
- Check the condition of the oil at the same time.
- If the oil level is too low, top it up.
- **DO NOT** overfill. Pour small quantities of oil into the engine and recheck frequently.

ii. Check coolant level



**DO NOT** remove the radiator cap when the engine is hot. Steam and boiling water may blow out and can cause extremely serious skin burns or blindness



**Check coolant level at the reservoir when the engine is cold**

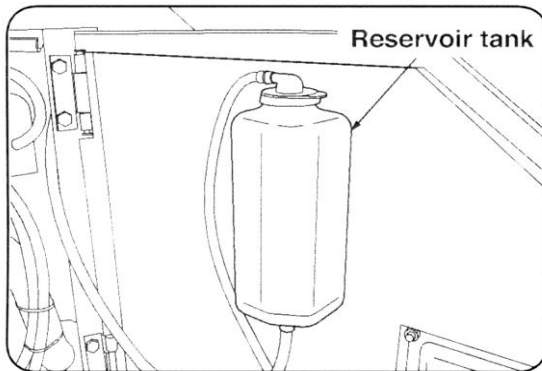

- A proper level of coolant is between the 'FULL' and 'LOW' marks on the reservoir.
- If the water level is at the 'LOW' mark, top up the reservoir to the 'FULL' mark.
- If there is no water in the reservoir, remove the radiator cap and fill with coolant up to the neck of the radiator.

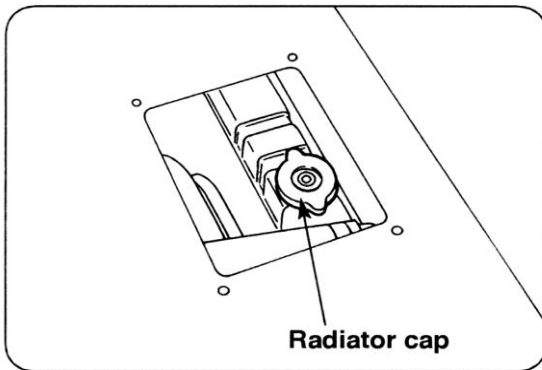

iii. Fan belt tension



**DO NOT** attempt any inspection or adjustment of the fan belt with the engine running

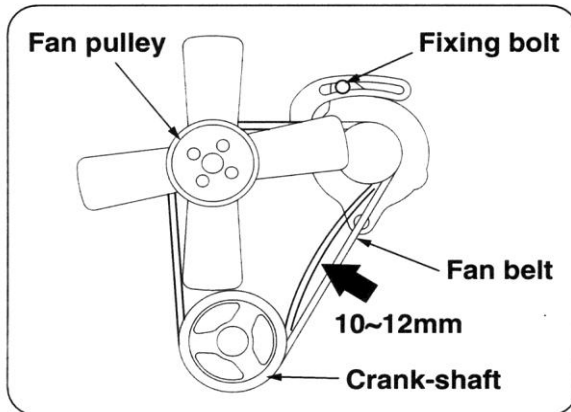

- Check the fan belt for tension and damage.
- To check for proper tension, find the centre of the belt between the fan pulley and the crankshaft.
- Press with your finger (approximately 10kg of force) and belt should deflect no more than 10-12mm.
- If an adjustment is needed, loosen the fixing bolt for the alternator and move it until the proper tension is obtained.

iv. Battery electrolyte level



**EXTREMELY FLAMMABLE** Hydrogen Gas is given off from battery electrolyte solution. This burns hot enough to combust skin on contact and has no flame. **DO NOT** smoke or bring naked lights close to the battery when topping up or charging – **YOU MAY DIE**



**DO NOT** allow the electrolyte to splash on to your body or clothing. Electrolyte contains sulphuric acid which may cause severe burns or blindness. If your clothing is splashed remove at once. If your skin or eyes are splashed wash immediately with copious amounts of water for at least 10 minutes. Seek medical assistance immediately afterwards.



**ALWAYS** wear rubber gloves, cotton clothing and chemical resistant safety goggles when handling batteries



If the crane is stored for any length of time disconnect the negative (-) battery lead. The battery will require charging using the following regime:

Warm weather:	Once a month
Cold weather:	Once every other month

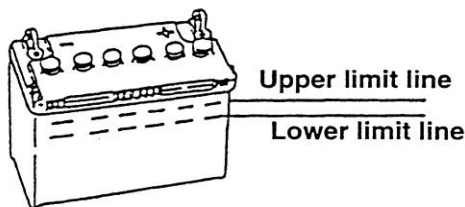

- Check that the battery electrolyte level is between the upper and lower limits with the battery placed on a level surface.
- If the solution is below the lower limit remove the caps and top up with distilled or de-ionised water.
- Tighten the caps securely after topping up.
- **DO NOT** overfill. If the electrolyte is above the upper limit it may leak and corrode the carrier body.

v. Check hydraulic oil level



**DO NOT** attempt any work with the hydraulic system when the carrier has been operating. The temperature of the oil and components, including the tank can reach 80°C



Replace hydraulic oil after first three months of operation, then annually

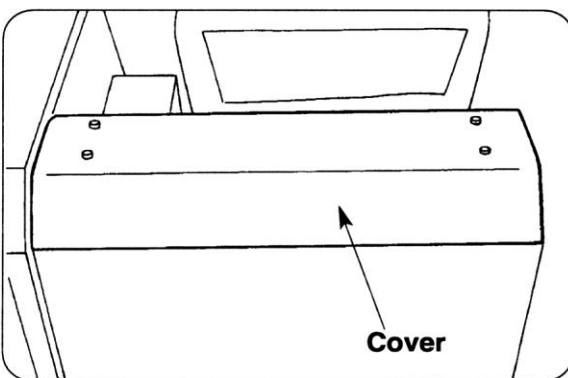
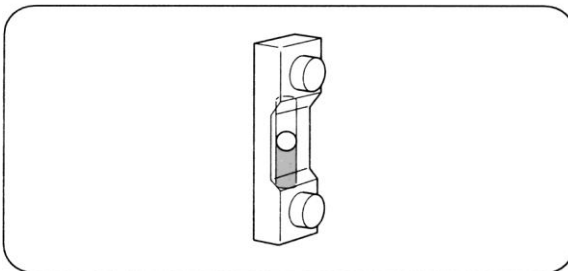
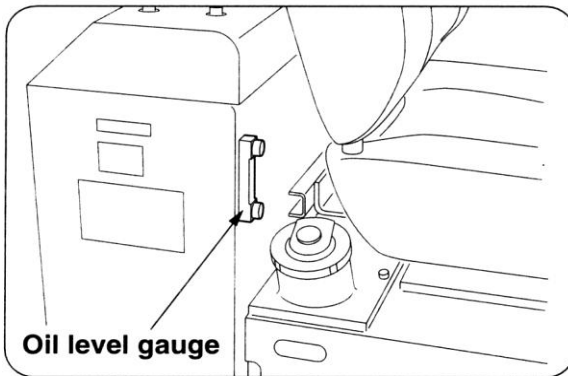

- Ensure the carrier is parked on level ground.
- Check the level of the hydraulic oil on the oil level gauge located in the front of the oil reservoir.
- The proper level is between the 'UPPER' and 'LOWER' limits illustrated left
- If the oil level is below the 'LOWER' limit, remove the tank cover, remove the cap and top up with specified oil.



vi. Check for track tension



**DO NOT** work on tracks with the carrier body raised of the ground on its outriggers



Track tension testing must be carried out with the tracks touching the ground

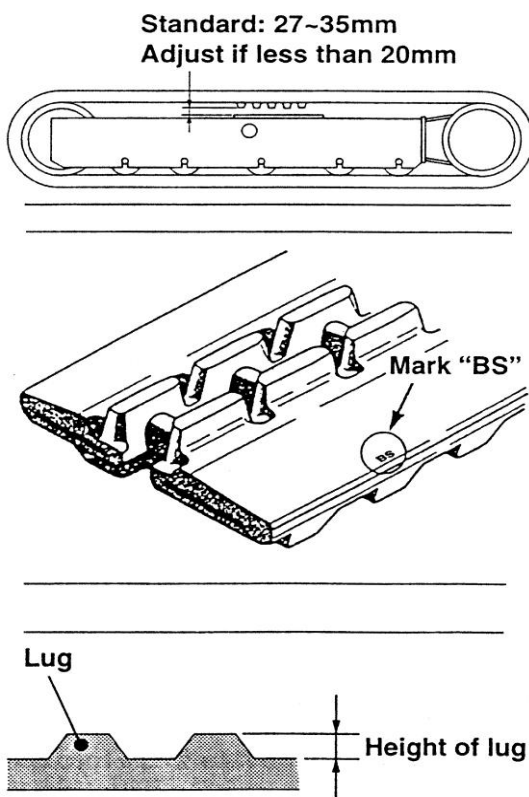

- Check the rubber track for wear and tension regularly as wear varies according to operating and ground conditions.
- Check track tension with the seam of the track positioned at the centre between the wheels on the opposite side to the ground.
- Positioning the 'BS' mark between the wheels on the ground side ensure the correct positioning of the seam.
- Wrong positioning allows greater slack in the track which causes wrong tensioning.
- If the tension is too tight it will shorten the life of the sprockets.
- Replace the track when the lug height is below 3mm



**DO NOT** unscrew the grease plug by more than one turn. Grease under pressure may be ejected which can be injected under the skin or in the eyes



**DO NOT** undo the grease nipple at this time

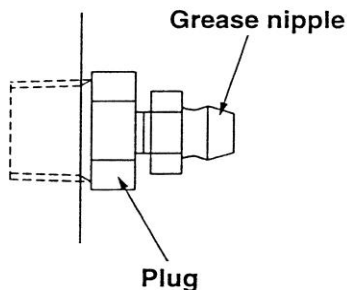
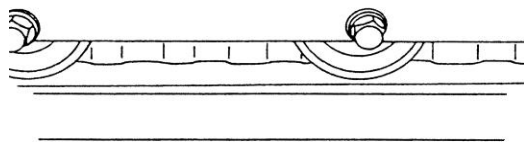
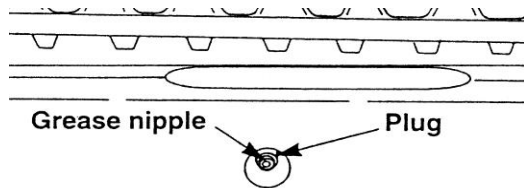

- Undo the plug by one turn only.
- Inject the grease into the grease nipple to extend the track tensioning cylinder.
- Move the track backwards and forwards and then check track tension again.
- If the tension is too high **SLOWLY** undo the plug until grease starts to seep out. **DO NOT** open it any more.
- Allow the track to go slack (under adjusted) and tighten the plug and open one turn. Follow instructions for track tensioning.
- If the tension is too loose, even after all adjustment has been taken up, it will be necessary to replace the track or the seal in the track tensioning cylinder.
- See you UNIC service agent.

vii. Check for fuel level and how to drain water



**DIESEL FUEL VAPOUR is highly flammable.**



**NO SMOKING OR NAKED LIGHTS** when refuelling, draining sediment or working on the fuel system



**DO NOT** allow spilt fuel to build up. It is both a fire and slip hazard.

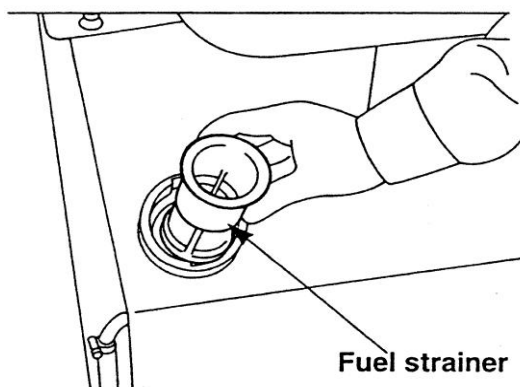
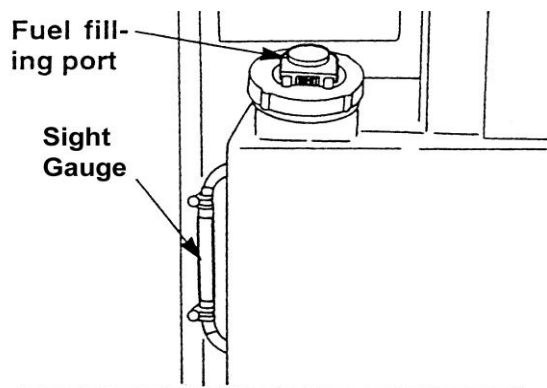

- Insert the key into the starter switch and turn it to the 'START' position for a few seconds to bleed the air from the fuel system.
- The fuel cap is located on the rear right side of the carrier.
- Check the sight gauge to ensure there is enough fuel before carrying on with inspection.
- When refuelling ensure the fuel strainer is fitted in the fuel filling port to stop dirt, etc. entering the fuel tank.
- Fill up the tank after every carrier operation or at the end of the day.
- Lock the fuel cap after refuelling!
- Fuel tank capacity: 40 litres

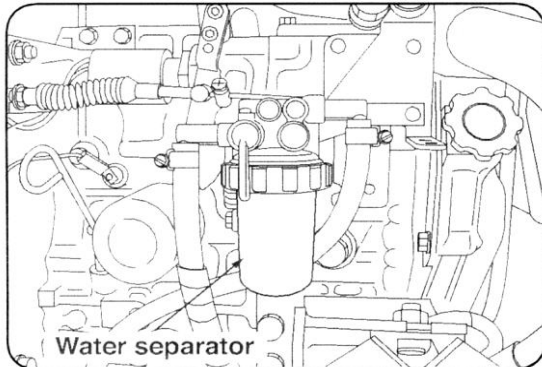

- Moisture that has become inadvertently mixed with the fuel is removed by the water separator.
- The water separator is built into the fuel filter and functions to separate water from the fuel.
- Check it everyday and remove it from the retaining ring and empty any accumulation if the float reaches the internal elements.

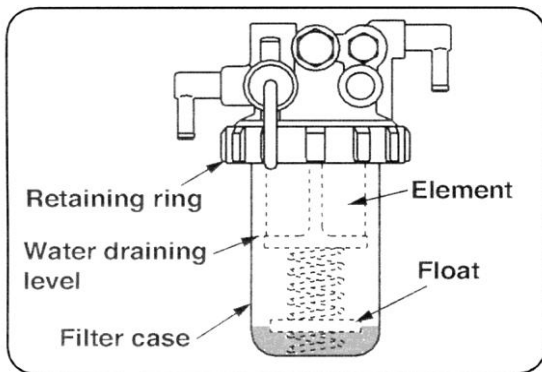

**NB**

**Do not crawl over rocks or stones which have sharp edges**

**Do not change direction when there is a difference in ground level**

**Do not make quick changes of direction as this may dislodge the track from its wheels**

**Do not allow oils such as diesel fuel, engine or hydraulic oil to remain on the track, wash them off immediately**

**Do not operate where there is a high salt content on the ground**

**For long time storage protect the vehicle from the sun and inclement weather**

**b. 250 hour or 3 monthly Inspection**

**i. Engine oil and oil filter replacement**



**CARCINOGENIC SUBSTANCE.** Used engine oil is classified as a carcinogenic substance in the HSE document EH40/XX (XX is the year). If in doubt about what precautions are required contact your company health and safety personnel or the local branch of the Health and Safety Executive



**ALWAYS** wear the appropriate Personal Protective Equipment. Used engine oil is a known primary vector in the causation of occupational dermatitis



**DO NOT** attempt to drain engine oil while it is still hot



**Use of oil filters that have been washed is strictly prohibited**

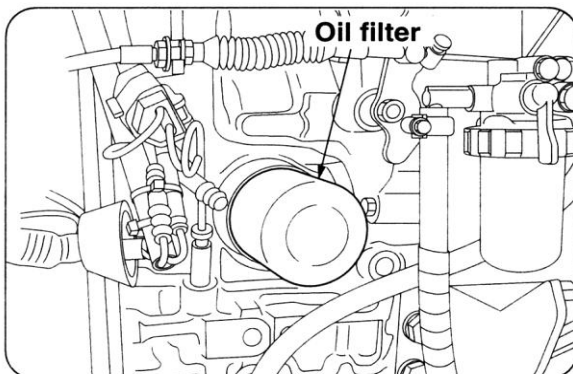
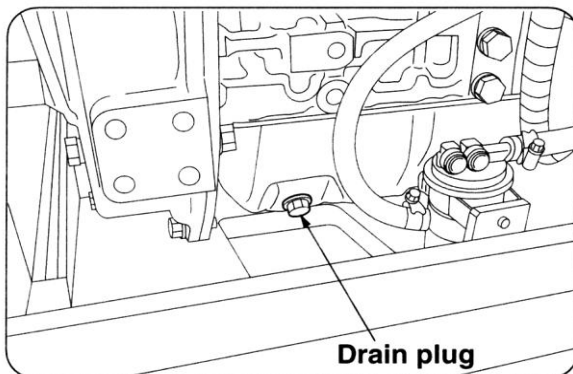

- The drain plug is located on the left side of the sump
- Place a container under the drain plug and oil filter
- Remove the drain plug and allow all the oil to drain out
- Replace and tighten the drain plug
- Turn the oil filter anti-clockwise to remove it. It may require the use of a strap or chain wrench if it is too tight to remove by hand

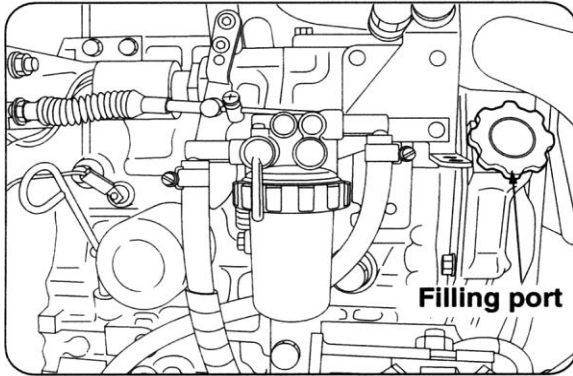
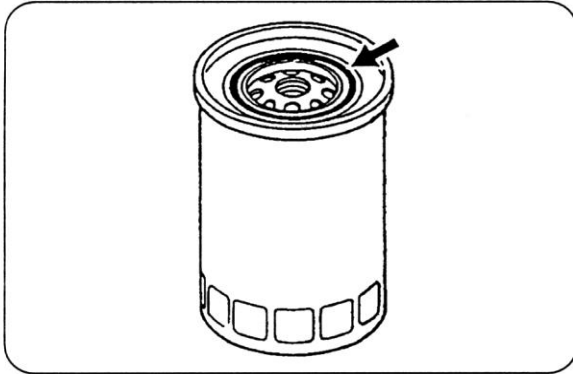

- Apply new oil sparingly to the 'O' ring seal of the new oil filter
- Clean the filter mounting plate on the engine
- Mount the new filter by rotating it clockwise on the screw thread until the filter touches the mounting plate surface
- Rotate another  $\frac{2}{3}$  of a turn
- Do not overtighten as this can damage the seal and lead to leakage
- Pour 3.1 litres of the specified oil into the filling port
- Idle the engine to check for oil leaks
- Stop the engine and wait for 5 to 10 minutes before checking the oil level again

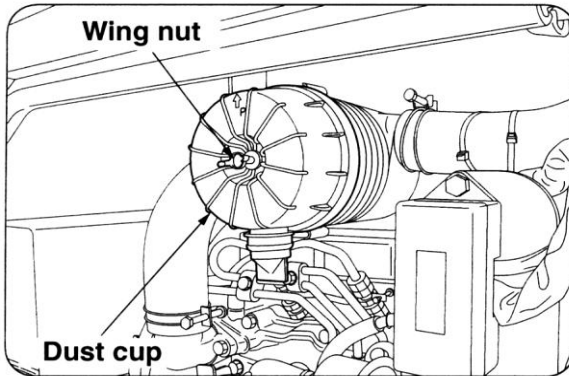

**ii. Checking the air filter element**

Check the air filter element every 250 hours or 3 months or when the air filter light comes on

- Unfasten the wing nut to remove the dust cap

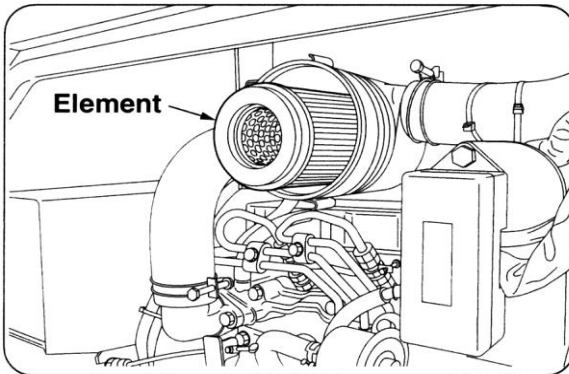

- Take out the air filter element to check and clean it.

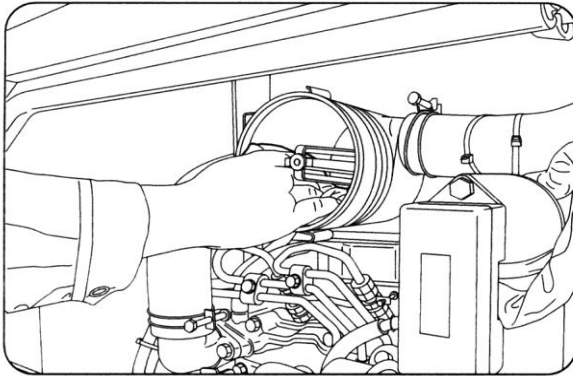

- Wipe out the inside of the filter housing with a clean cloth.

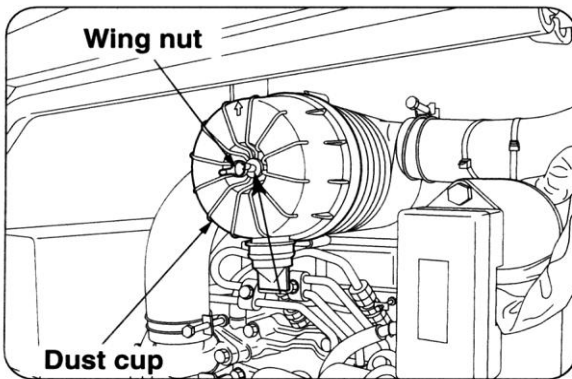

- Insert a new or the cleaned element
- Fit the cover and re-tighten the wing nut

iii. **Cleaning the air filter element**



**ALWAYS wear safety goggles and a dust mask when cleaning the element. DO NOT set the compressor output higher than 28 psi or 2 bar**



**Do not use an element that has been damaged in the folds or gasket**



**Do not wash with water**



**Do not strike the air filter element against any object when cleaning it**

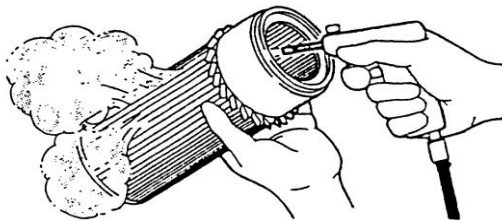

- Blow compressed air along the folds on the inside of the element
- Check the element visually by inserting a light source inside the element and looking around the outside of the element
- Replace if there are rips or tears of any size, pinholes or a particularly thin area of paper



**Do not clean an element more than 5 times regardless of its condition. It must be replaced at the next inspection**



iv. **Cleaning the fuel filter/water separator element**



**DIESEL FUEL VAPOUR is highly flammable.**



**NO SMOKING OR NAKED LIGHTS** when refuelling, draining sediment or working on the fuel system



**DO NOT** allow spilt fuel to build up. It is both a fire and slip hazard.



**DISCONNECT** the negative (-) lead from the battery before commencing work on the fuel system



**WEAR SAFETY GOGGLES** when cleaning the elements with compressed air. **DO NOT** allow compressor output to exceed 28 psi or 2 bar



**Do not** wash the elements with petrol

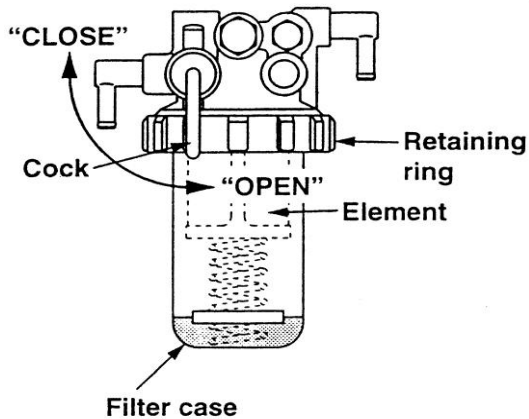
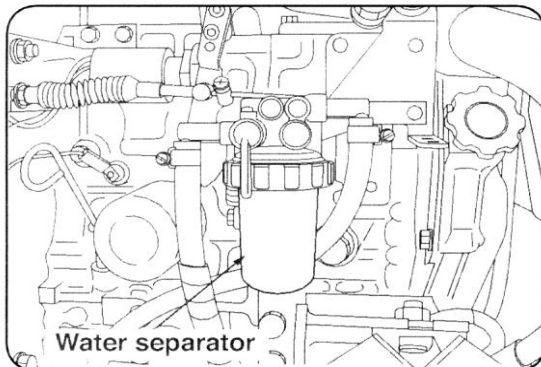

The fuel filter/water separator is to separate out and remove foreign objects and water from the fuel system

Regular cleaning is require to ensure the correct functioning of the filter.

- Turn the cock of the fuel filter to the 'CLOSE' position.
- Undo the retaining ring to remove the filter case and the element
- Wash the element with clean diesel and blow through the inside of the element with compressed air
- Remove sediment and moisture from the bottom of the filter case
- Check the 'O' ring and replace it if damaged
- Fit the cleaned element into the fuel filter case and hand tighten
- To avoid over-tightening only turn the retaining ring  $\frac{2}{3}$  of a turn once the seal has contacted the retaining ring
- Turn the cock to the 'OPEN' position
- Bleed the air in the fuel system and check for fuel leaks

v. Check crawler motor reduction gearing oil level



**DO NOT** work on the crawler motor for at least 20 minutes after the carrier has finished operating as there is a high temperature hazard with the motor casing and oil



**BEWARE** there is a high pressure oil hazard inside the reduction gears. Open the filling port plug **NO MORE** than 2 – 3 turns to release the internal pressure

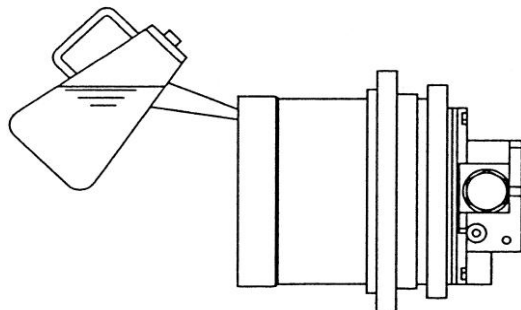
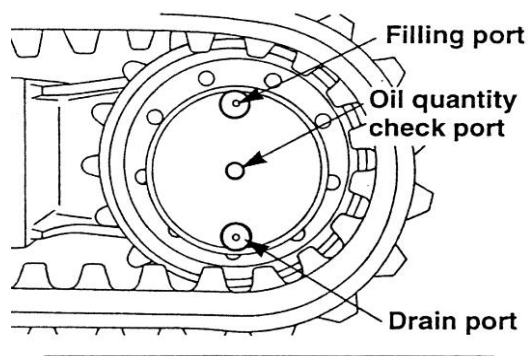

- Park the crane on flat ground
- Position the sprocket so that the 3 plugs are as shown in the illustration and stop the engine
- Unfasten the filling port slowly to release pressure
- Remove the plugs for the filling port and oil quantity check port
- If oil flows from the oil quantity check port it is at the correct level
- If not fill it up until it does
- Check the 'O' rings of each plug and replace with a new one if they are damaged
- Replace and tighten both plugs



**c. 500 hour or 6 monthly Inspection**

Carry out the 250 hour or 3 month Inspection, except that the fuel filter/water separator is replaced rather than cleaned

**i. Replacing the fuel filter/water separator element**



**DIESEL FUEL VAPOUR is highly flammable.**



**NO SMOKING OR NAKED LIGHTS when refuelling, draining sediment or working on the fuel system**



**DO NOT allow spilt fuel to build up. It is both a fire and slip hazard.**



**DISCONNECT the negative (-) lead from the battery before commencing work on the fuel system**



**WEAR SAFETY GOGGLES when cleaning the elements with compressed air. DO NOT allow compressor output to exceed 28 psi or 2 bar**

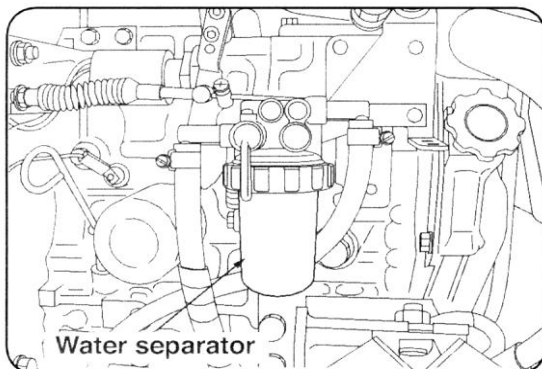

The fuel filter/water separator is to separate out and remove foreign objects and water from the fuel system

Replace it regularly as it becomes clogged over a period of time and fails to function correctly allowing debris and water to enter the system.

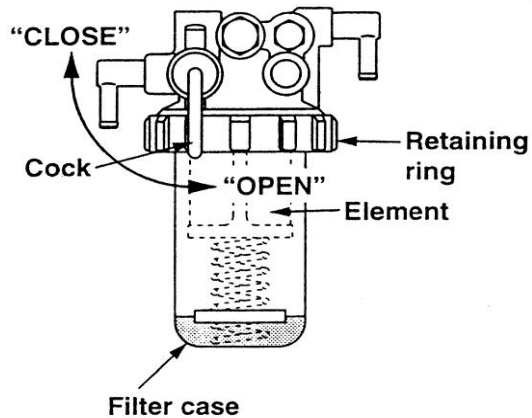

- Turn the cock of the fuel filter to the 'CLOSE' position.
- Undo the retaining ring to remove the filter case and the element
- Wash the filter case with clean diesel, in addition replace the old 'O' ring with a new one
- Remove sediment and moisture from the bottom of the filter case
- Fit the replacement element into the fuel filter case and hand tighten
- Ensure the 'O' ring is not twisted or dislodged when tightening
- To avoid over-tightening only turn the retaining ring  $\frac{2}{3}$  of a turn once the seal has contacted the retaining ring
- Turn the cock to the 'OPEN' position
- Bleed the air in the fuel system and check for fuel leaks

**d. 1000 hour or 12 monthly Inspection**

This inspection is carried out in addition to the 500 hour or 6 month Inspection.

**i. Replacement of hydraulic oil and cleaning strainer**



**DO NOT** attempt any work with the hydraulic system when the carrier has been operating. The temperature of the oil and components, including the tank can reach 80°C



**WIPE UP** any spills as these cause a fire and slip hazard



**ALWAYS** wear the appropriate Personal Protective Equipment. Hydraulic oil (both new and used) is a known primary vector in the causation of occupational dermatitis

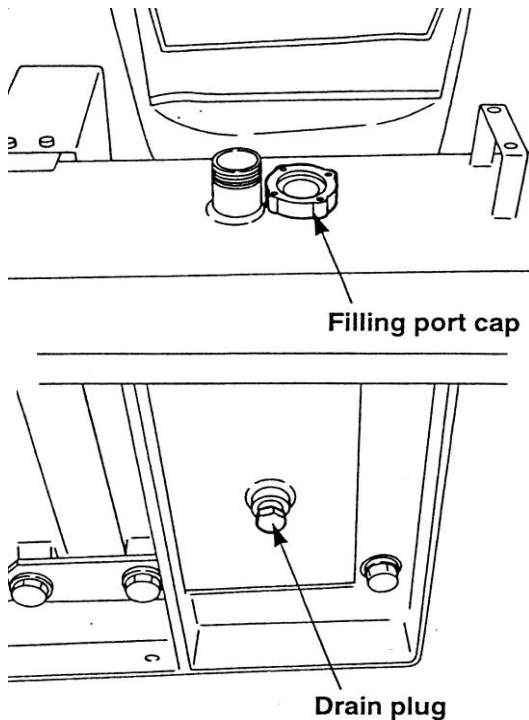

Replace hydraulic oil together with the line filter element

- Park the vehicle on flat ground and stop the engine
- Move each control lever to relieve internal pressure in the hydraulic system
- Slowly remove the filling cap
- Place a container capable of holding 70 litres under the drain plug
- Remove the drain plug

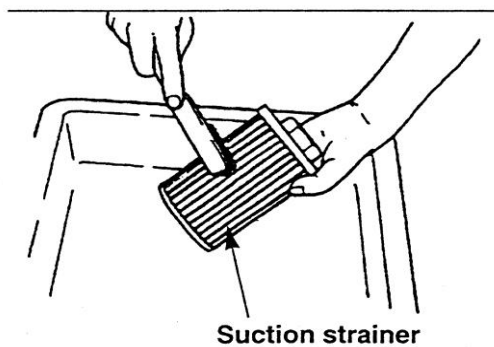
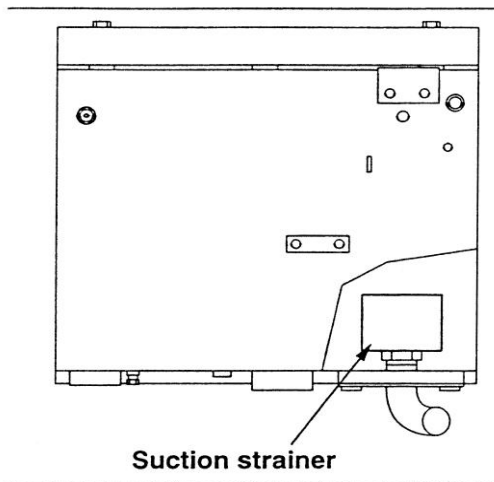
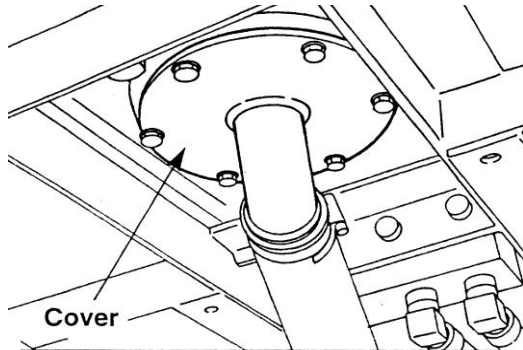

- After the tank is drained, remove the cover and remove the strainer
- Remove any dust or debris stuck to the strainer
- Wash it with a non-flammable washing oil
- Replace the strainer if it is damaged
- Wash inside the tank with the washing oil
- Check the 'O' ring on the cover and replace it if damaged
- Put new sealing tape on the drain plug
- Refit the cleaned strainer
- Tighten the drain plug

Then replace the line filter element

## ii. Replacement of line filter element

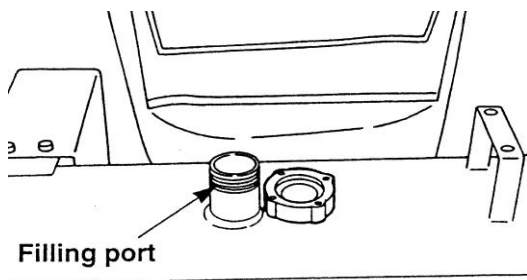
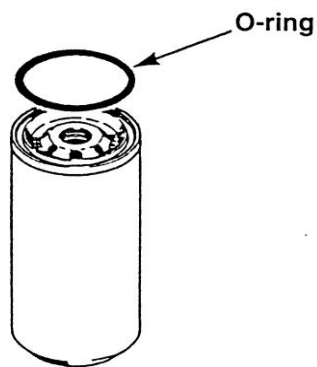
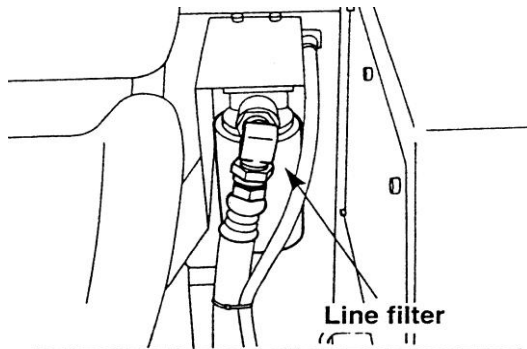

The line filter is located inside the cover at the front of the tank

- Place a container under the bottom of the line filter to catch any oil that may drain
- Turn the line filter anti-clockwise to remove it. Use of a strap or chain wrench may be required
- Apply clean oil sparingly to the 'O' ring on the new filter
- Clean the filter bed and fit the new filter.
- Avoid over tightening by only rotating the filter  $\frac{2}{3}$  of a turn after the 'O' ring touches the filter bed plate
- Pour the new specified hydraulic oil into the tank. Capacity 70 litres
- Fit the filling port plug and tighten
- Bleed the air in the hydraulic system by:
  - Idling the engine and extending and retracting each hydraulic cylinder in turn
- **Stop the cylinders from operating fully as the seals may be damaged by air entering the system. Only operate to 10cm of the end of the stroke**
- Repeat 3 times for each cylinder

**NB**

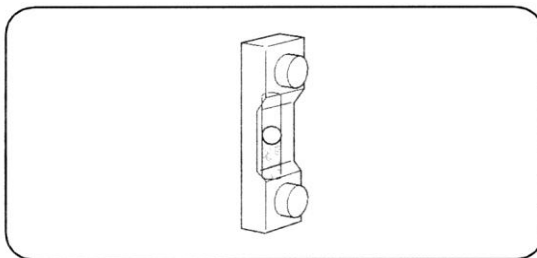
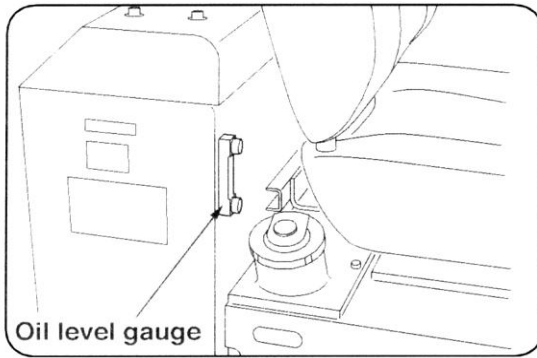

- Level the vehicle, stop the engine and check the oil level gauge
- The correct level should be between the upper and lower limits as illustrated
- If required top up the tank with the specified oil



**iii. Replace oil in crawler motor reduction gear**



**DO NOT** work on the crawler motor for at least 20 minutes after the carrier has finished operating as there is a high temperature hazard with the motor casing and oil



**BEWARE** there is a high pressure oil hazard inside the reduction gears. Open the filling port plug **NO MORE** than 2 – 3 turns to release the internal pressure

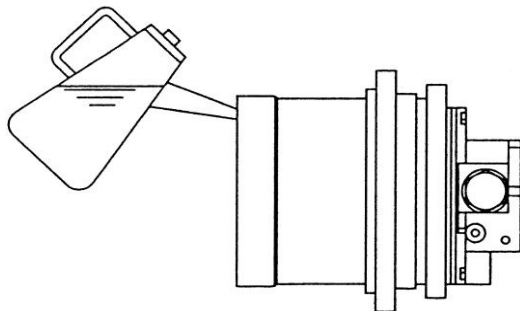
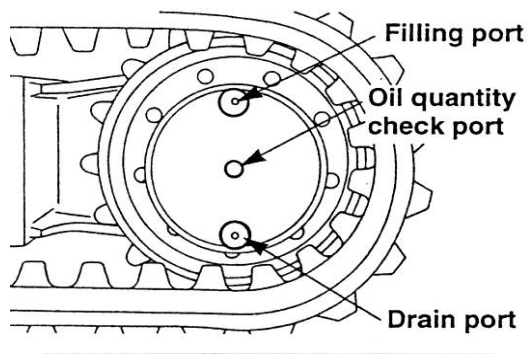

- Park the crane on flat ground
- Position the sprocket so that the 3 plugs are as shown in the illustration and stop the engine
- Unfasten the filling port slowly to release pressure
- Place a container under the drain plug
- Remove the drain plug first and then the other two to ensure the oil drains completely
- Check the 'O' rings of each plug and replace with a new one if they are damaged
- Replace and tighten the drain plug. Then fill with the specified oil until the oil runs from the oil quantity check port
- Replace both remaining plugs and tighten

e. Non-regular maintenance

i. Checking and replacing coolant



**DO NOT** remove the radiator cap when the engine is hot. Steam and boiling water may blow out and can cause extremely serious skin burns or blindness

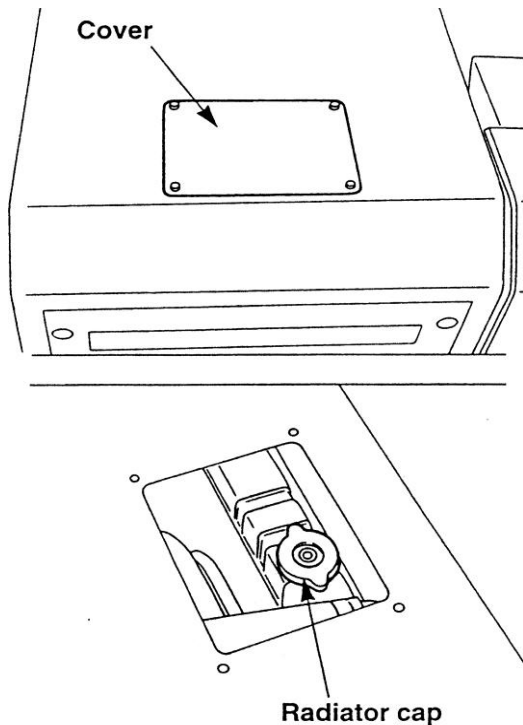

When replacing the coolant refer to the list of recommended lubricants

Ensure that the cooling system is washed through each time you replace the coolant as any scale or rust that has formed in the system will prevent it from operating efficiently and cause the engine to overheat

- Park the vehicle on level ground, switch of the engine and allow to cool for at least 30 minutes
- Remove the cover located on the top of the engine compartment and rotate the radiator cap slowly to release any internal pressure remaining
- Remove the radiator cap completely

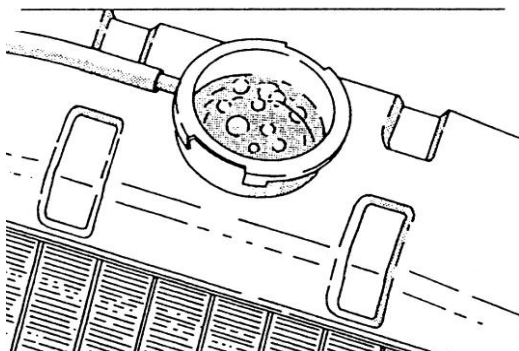
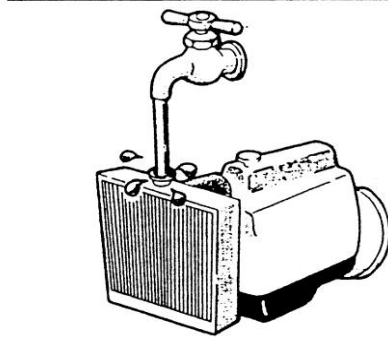
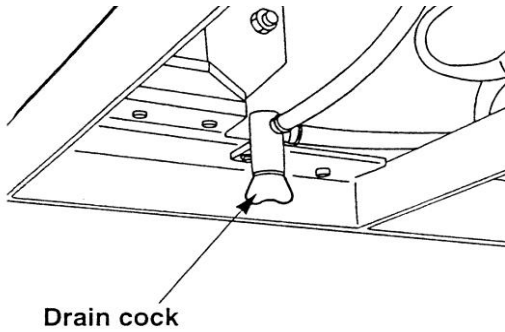

- Undo the drain cock and drain all the coolant
- Close the drain cock
- Wash with a commercially available cooling system detergent in accordance with their instructions
- Run the engine at a fast idle to raise the water temperature to more than 80°C and keep it running for approximately 30 minutes
- Turn off the engine and open the drain cock, allow the detergent to drain thoroughly
- Close the drain cock and fill with tap water through a hosepipe
- Run the engine and then repeat the draining process
- Repeat this until clear water is discharged
- Pour 5 litres of the correct mixture of coolant into the radiator
- Run the engine on idle with the radiator cap removed to bleed any air from the system

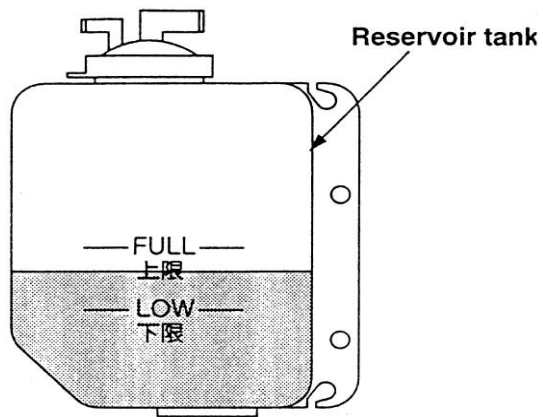

- Stop the engine
- Fill the radiator up to its neck
- Fill the reservoir until it is up to the 'FULL' mark

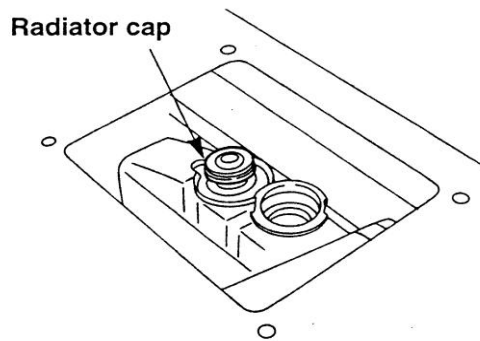

- Check the radiator cap for seal damage or fatigue in the spring. If in doubt replace the cap for a new one
- Fit the radiator cap securely

**ii. Inspection and maintenance of the fuel tank**



**DIESEL FUEL VAPOUR is highly flammable.**



**NO SMOKING OR NAKED LIGHTS** when refuelling, draining sediment or working on the fuel system



**DO NOT** allow spilt fuel to build up. It is both a fire and slip hazard.

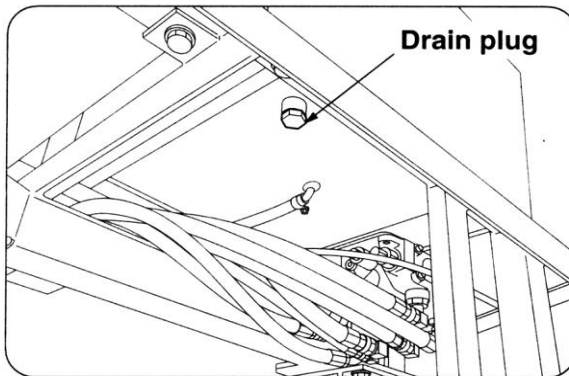

The only time the fuel tank needs to be cleaned is when it is repeatedly hard to start or is not delivering sufficient power due to poor fuel supply

- Place a container under the drain plug to receive any fuel
- Remove the drain plug
- Remove the cover from the bottom of the fuel tank
- Wash the inside of the fuel tank with a non-flammable wash oil to remove any debris deposited on the bottom of the tank
- Remove debris from the strainer and check for damage
- Replace if damaged
- Cover the screw threads on the plug with sealant tape, replace and tighten
- Fit the cover and fill up with fuel
- Bleed the air in the system and check for leaks
- In order to bleed the air out of the fuel system, turn the ignition switch to 'START' for a few seconds until the engine starts

**iii. Cleaning and inspecting the radiator**



**WEAR SAFETY GOGGLES** when cleaning the elements with compressed air.  
**DO NOT** allow compressor output to exceed 28 psi or 2 bar



**INJECTION HAZARD.** High pressure air and high pressure water are easily injected under the skin, the results of which are potentially fatal

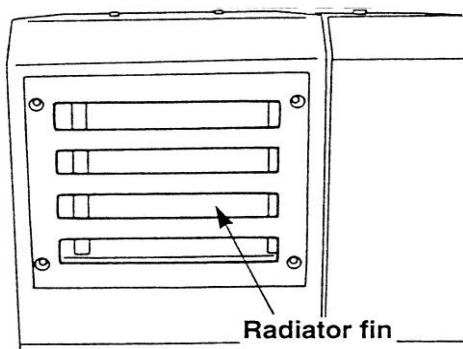

If the fins are with debris such as leaves or mud, etc. it will prevent the air blowing correctly over the cooling fins.

This decreased cooling efficiency can easily lead to an overheating engine

Use compressed air or high pressure water to clean the fins

If using water take care not to get the alternator wet

**f. Storage**

Stop the engine and thoroughly remove dirt and debris stuck on the carrier body. In particular, be sure to remove the debris stuck to the battery, electric wiring and any parts directly affected by heat, such as the silencer as this could cause a fire

Shift each crawling lever to the neutral position to lock it

If the ambient temperature is expected to drop below 0°C ensure that the coolant has a sufficient proportion of anti-freeze in its mixture

Avoid storing the crane in direct sunlight

Disconnect the negative (-) side of the battery





**13 MAINTENANCE AND INSPECTION OF CRANE**



**DO NOT** carry out any maintenance work until power to the crane and carrier is isolated. A 'MAINTENANCE IN PROGRESS' warning signboard must be hung over the controls in the drivers position prior to any maintenance work being carried out.

**NB**

All replaceable items must be replaced according to the criteria outlined in this manual. Failure to do so may cause damage to the machine and will invalidate any current warranties.

**NB**

When parts need replacing (other than running spares) or anything abnormal is found contact your local UNIC dealer for, inspection, replacement or advice.

**a. Pre-use inspection**

Device	Servicing Item	Device	Servicing Item	Device	Servicing Item
Hydraulic pump	Tightness of each mounting, oil leakage, unusual noise	Hook	Rotation of hook, function of hook retaining mechanism	Frame	Mounting of crane body, cracks, tightness of bolts, missing bolts
Hydraulic oil tank	Oil level, oil leak	Wire rope	Damage, condition of rope end fixing	Slinging implements	Items necessary for crane operation are available
Outrigger	Normal function, deformation, damage, oil leakage, cracks	Overwind alarm	Function, proper alarm sound	Automatic hook storage	Function of automatic stop and storing operation
Winch drum	Function, braking function, irregular winding	Interlock for crane-crawl lever	Crane must not function when in crawl position. Carrier must not drive when in crane position	Automatic stop for minimum rope	Unwinding stops when only 3 turns of rope are left on drum
Slewing device	Function, oil leakage	Warning horn	Function	Rated Capacity Indicator	See chapter 18 for checks and operation of the Rated Capacity Indicator
Derricking boom	Function, oil leakage, mounting of foot pin	Piping, hydraulic hose	Oil leakage, damage		
Telecoping boom	Function, oil leakage, deformation, cracks, mounting of fixing bolts	Extension Jib	Function Deformation Cracks Mounting of fixing pins		

**b. Cleaning**



When washing with high-pressure water take particular care not to let water get into the electrical system. This may well cause the crane or carrier to malfunction creating a hazard

Keep the crane clean at all times

Sand and dust will cause accelerated wear on carrier and crane parts, ensure the vehicle is particularly well after operating in these environments

**c. Inspection of slew bearing mounting bolts**



**ENSURE** the outer ring mounting bolts are checked for correct torque every 6 months. Breakage of the bolts could lead to collapse of the boom

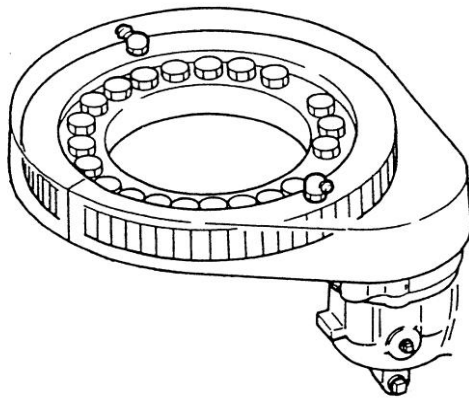

If the slew ring makes an unusual noise when operating or crawling, or excessive movement is observed when operating the crane, or if a gap is observed on the mounting surface, contact your UNIC service agent immediately for inspection and/or repair

**d. Inspection of wire rope**

Wire rope is an expendable item. It may be damaged in many ways leading to a reduction in its safety factor. Replace the rope according to the following criteria.



**Wear leather gloves when replacing the wire rope**

**i. Replacement criteria**

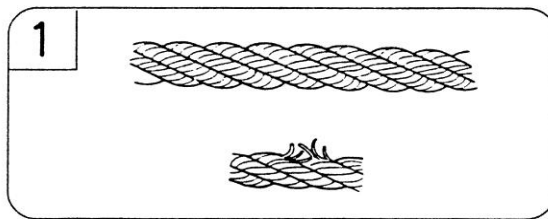

1. A rope in which the amount of wire strands (except filler wires) is more than 10% within the pitch of the twist

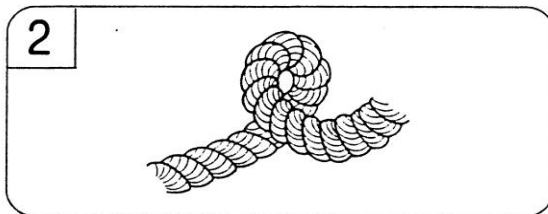

2. When a rope is kinked. It may be a twisted kink as illustrated, or a flat kink

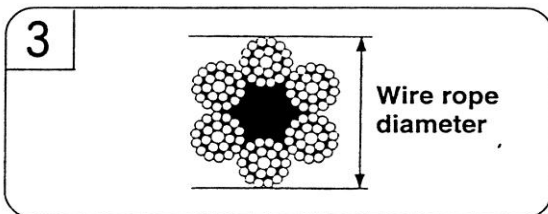

3. A rope whose diameter has decreased by more 7% of the nominal diameter. For example: where a rope of 8mm nominal diameter is used, replace it when any part of the rope is 7.5mm

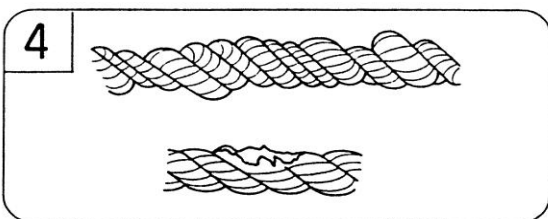

4. A rope that has become deformed or excessively corroded

ii. Replacing the rope

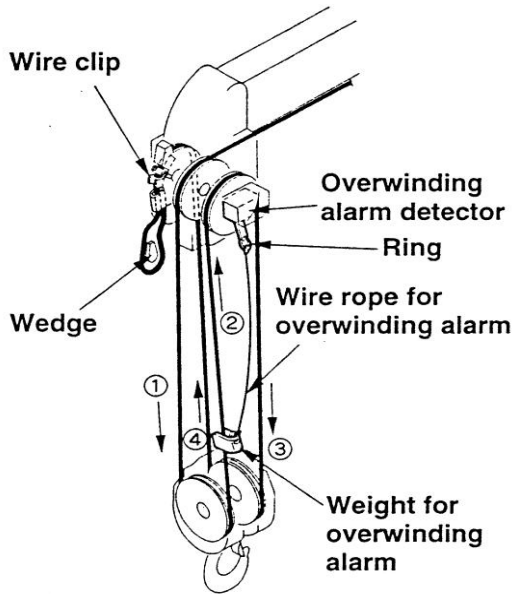

- Refer to the figure on the left to follow the routing of the rope and where the weight for the overwind alarm is to be mounted

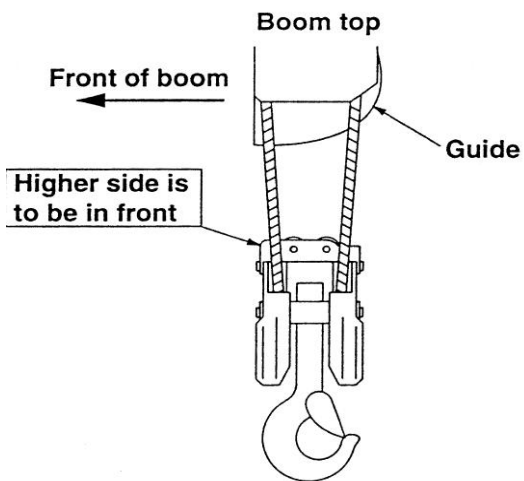

- Refer to the figure on the left for the correct way to attach the hook block
- **NB** Failure to follow this will stop the hook block from auto stowing

**NB**

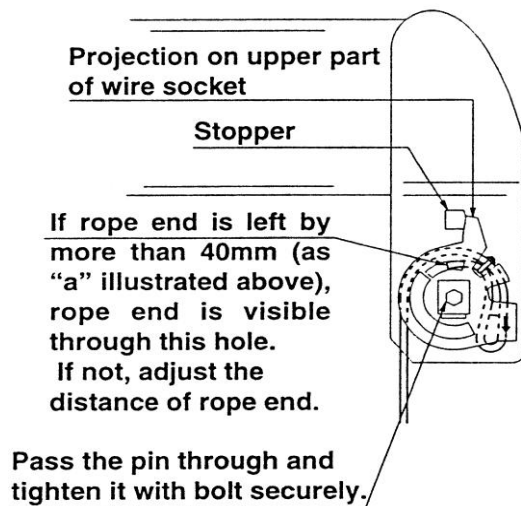
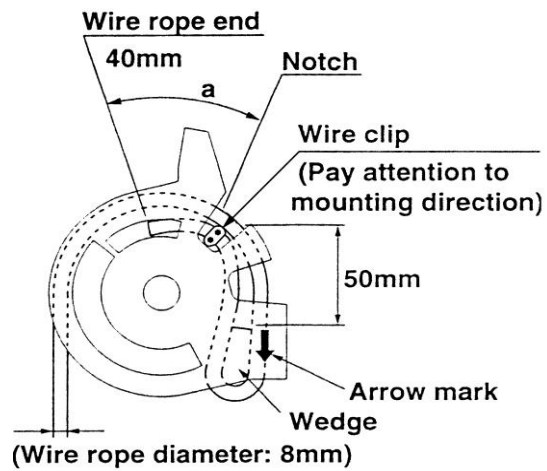

#### How to fix the wire rope ends

- Remove the bolt holding the wire socket on the end of the boom
- Remove the wire clip, knock out the wedge and remove the old rope
- Remove the old rope from the winch drum
- Refit the new rope to the winch drum
- Feed the rope through the guides on the boom and route it through the hook block as shown previously
- When passing the new wire rope end through the socket, be sure to pass it as indicated by the arrow mark on the socket
- If it is passed the other way the rope will be permanently bent, shortening the life of the rope
- Always mount the wedge and wire clip as illustrated left
- Ensure there is more than 40mm between the notch and the wire end as shown at 'a'
- Re-position the wire socket in the boom end and tighten securely

**lii How to correct twisted ropes**

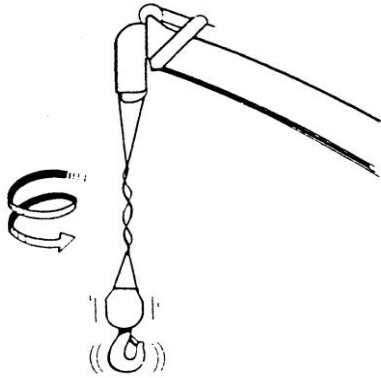

Wire ropes tend to turn in their 'untwisting' direction when under tension

When fitting a new rope the twist should be taken out when fitting the rope to the drum

If wire ropes are twisted, correct them as follows:

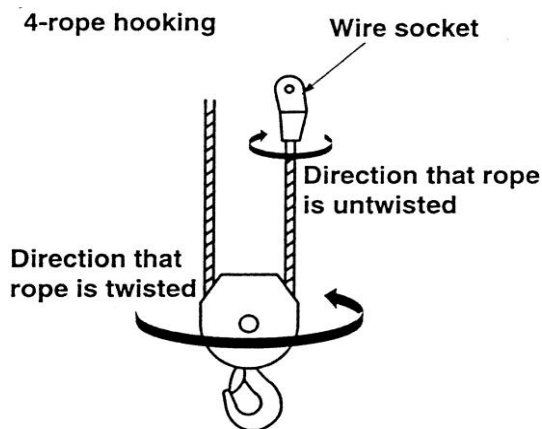

**(Note)** Rotate wire socket to the direction opposite to wire ropes have been twisted.

- Unload the hook
- Extend the boom fully
- Raise the boom to an approximate angle of 65°
- Unwind the hook until it is almost on the ground
- Check how many twists are in the rope
- Wind up the hook and stow the boom
- Remove the wire socket and turn it in the 'untwisting' direction the number of twists multiplied by the number of falls. That means the socket must be untwisted a minimum of 4 turns with a 4-fall hook
- Re-attach the wire socket, extend boom fully and raise to an angle of 65°.
- Wind the rope up and down to its extremes 3 times. Check for twists
- If it remains twisted repeat the above procedures



**iv. Overwind alarm wire rope**

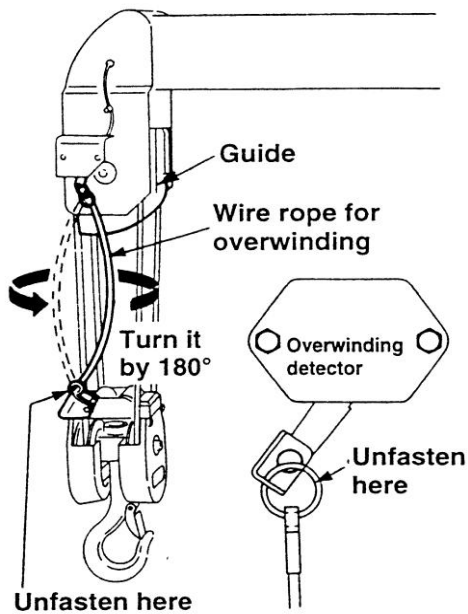

When the overwind alarm wire rope looks like it may get trapped between the hook block and boom end when stowing, unfasten the rings holding both ends, rotate through 180° and re-attach the rings

**v. Replacement of expendable parts**

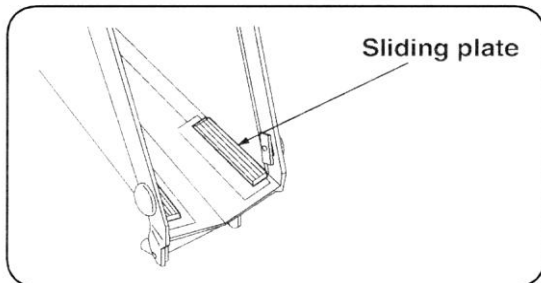

➤ Although timing of replacement parts varies according to how frequently the crane is used and environmental conditions, replace hydraulic cylinder gaskets and seals every 3 calendar years (this includes the periods the crane is not in use).

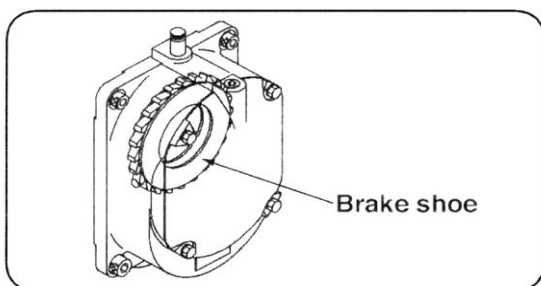

➤ Replace the sliding plates in the boom every 3 calendar years

➤ Replace the brake shoe in the winch drum every 3 calendar years

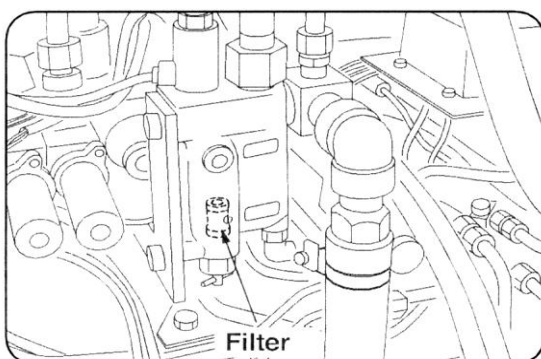



**Intentionally Blank**



**14. CARRIER LUBRICATION AND COOLANT**



**DO NOT SMOKE, EAT OR DRINK** when handling hydraulic oil, grease or fuel



**DO NOT** attempt any work with the hydraulic system when the carrier has been operating. The temperature of the oil and components, including the tank can reach 80°C



**WIPE UP** any spills as these cause a fire and slip hazard



**ALWAYS** wear the appropriate Personal Protective Equipment. Hydraulic oil (both new and used) is a known primary vector in the causation of occupational dermatitis

**a. Precautions when carrying out lubrication and coolant filling**

Lubricate in accordance with the Lubrication Charts and bear the following points in mind

- Cleaning filling ports and grease nipples thoroughly before carrying out any replenishment
- Always use new lubricant and prevent the entry of dust and debris
- When replenishing grease, inject it until old grease is forced out

**b. Recommended lubricants**

Use engine oil as shown below:

Classification	Depending on ambient temperature						
	-30	-20	-10	0	10	20	30
Engine oil Diesel engine oil of CD class	SAE 5W		SAE 30				
	SAE 10W			SAE 10W - 30			



**Recommended hydraulic oil**

Manufacturer	Brand	
	ISO VG 22	ISO VG 46
SHELL	Shell Tellus Oil 22	Shell Tellus Oil 46
CALTEX	Spindura Oil 22	Rando Oil 46
ESSO	Spinesso 22	Teresso 46
MOBIL	Mobil DTE 22	Mobil DTE Oil Mittel

**Recommended gear oil**

Manufacturer	Brand
SHELL	Shell Spirax EP 90
CALTEX	Universal Thuban SEA 90
ESSO	Standart Getriebe Oil 90
MOBIL	Molyube GX 90

**Recommended grease**

Manufacturer	Brand
SHELL	Retinax AM
CALTEX	Molytex Grease EP2
ESSO	Beacon G2
MOBIL	Mobyplex Special

**Recommended gear oil for crawler motor reduction gearbox**

Petroleum Maker	Brand
SHELL	DONAX TT or TD
CALTEX	RPM TRACTOR HYDRAULIC FLUID
CHEVRON	TRACTOR HYDRAULIC FLUID
TEXACO	TDH
MOBIL	MOBILAND SUPER UNIVERSAL

**c. Carrier lubrication and water filling chart**

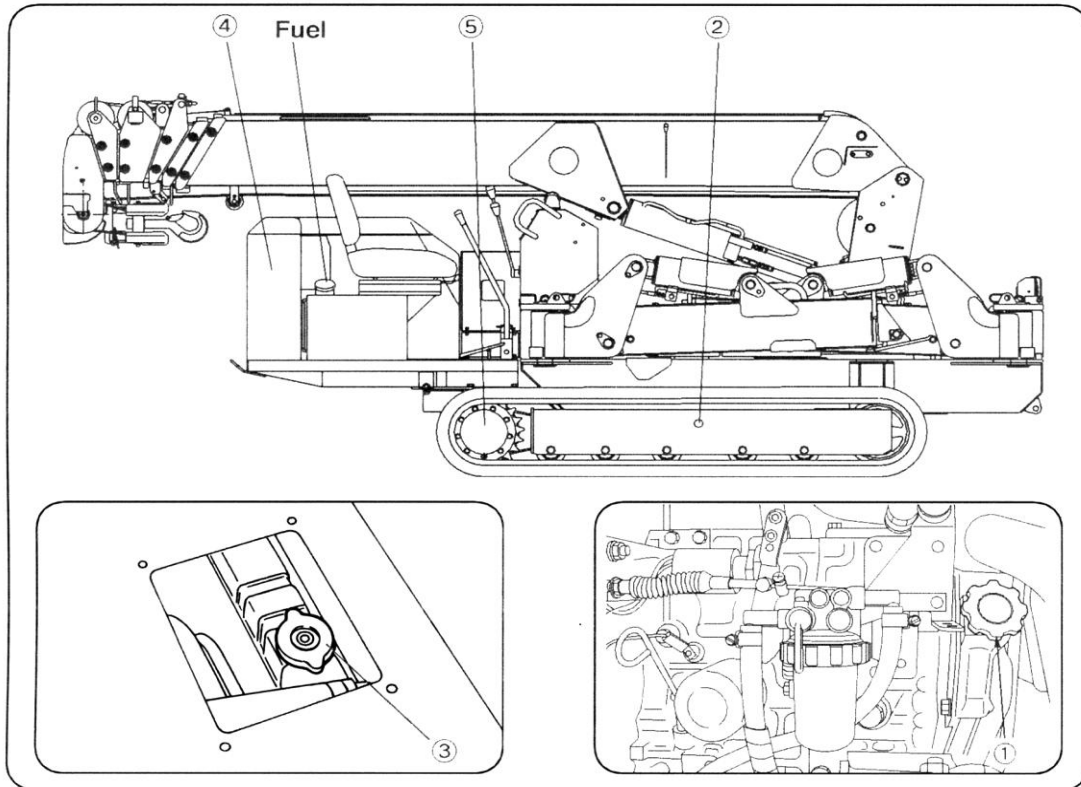

Picture is of URW 376, filling and lubrication of URW 506 is identical, URW 706 differences as indicated.

Service Interval	Where to lubricate	Number of parts	Lubricant	Tool
Initial: Replace every 100 hours After: Replace every 250 hours	Engine 4,0 litres (706 4,5 litres)	1	Engine oil	
Initial: 30 hours After: Whenever necessary	Tension adjustment of track	2	Chassis grease	Grease gun
Replace antifreeze solution every 2 years	Radiator 5,5 litres (706 6,0 litres)	1	Antifreeze solution	
Initial: Replace after 3 months After: Replace every year	Hydraulic oil tank (70 litres) (706 120 litres)	1	Hydraulic Oil	
Replace every 1000 hours	Crawler motor reduction gearbox (0,7 litres) (706 1,3 litres)	2 right/left	Diesel engine oil	

<b>Fuel</b>	Diesel
<b>Capacity 376/506</b>	40 litre
<b>Capacity 706</b>	74 litre



**Intentionally Blank**



## 15 CRANE LUBRICATION

URW 376 & 506

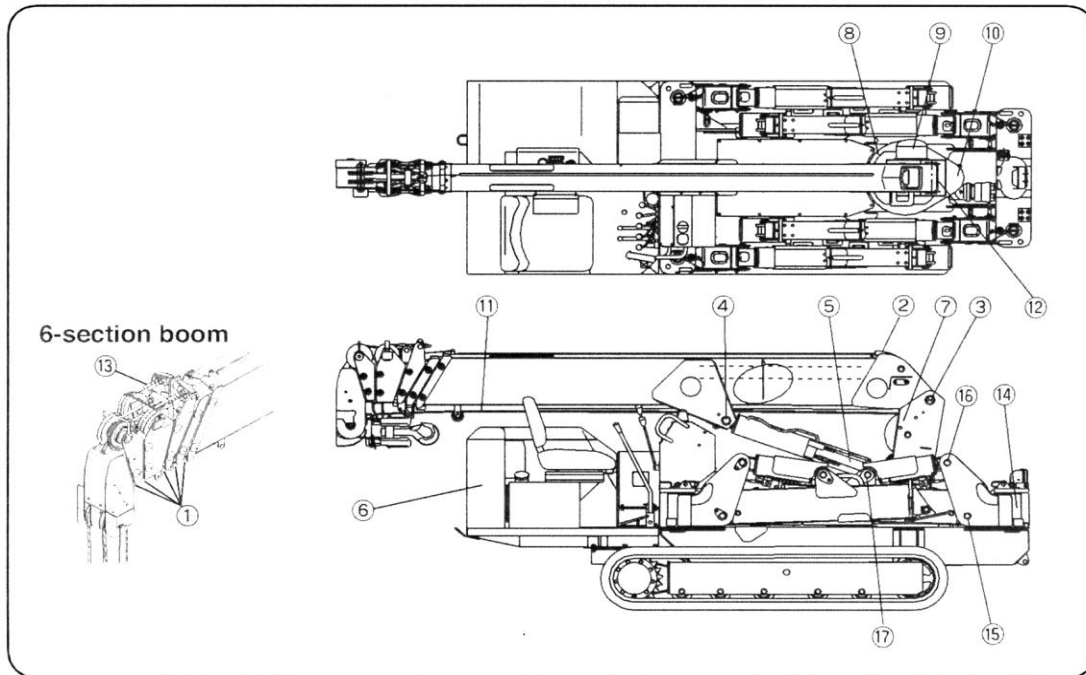

Picture is of URW 376, Lubrication of URW 506 is identical

### a. Crane lubrication chart

Service Interval	Where to lubricate	Nº of Parts	Lubricant	Tool
Daily	1 Boom slide plate (Underside and side face of boom extensions ②③④⑤⑥ for 6 section booms	5	Molybdenum grease	Manually
	2 Boom slide plate (Upper side of boom section ① )	2	Molybdenum grease	Grease gun
	3 Boom foot pin	1	Chassis grease	Grease gun
	4 Upper derrick cylinder support pin	1	Chassis grease	Grease gun
	5 Lower derrick cylinder support pin	1	Chassis grease	Grease gun
	6 Oil tank	1	Hydraulic oil	Manual
Weekly	7 Winch drum gears	1	Chassis grease	Grease gun
	8 Slewing gears	1	Chassis grease	Manually
Monthly	9 Winch reduction gears (approx. 1,0 litre)	1	Gear oil	Spray gun Grease gun Spray gun Grease gun Grease gun Grease gun Grease gun
	10 Slew reduction gears (approx. 0,7 litre)	1	Gear oil	
	11 Wire rope	1	Rope grease	
	12 Slew bearings	2	Chassis grease	
	13 Wire rope for boom extension	1	Rope grease	
	14 Outrigger fulcrum pin	4	Chassis grease	
	15 Outer box support	4	Chassis grease	
16 Outrigger vertical cylinder (Bracket side)	4	Chassis grease		
17 Outrigger vertical cylinder (Outer box side)	4	Chassis grease		

**b. Lubrication of reduction gears and slew gears**

**i. Replacement of gear oil (winch and slew reduction gears)**

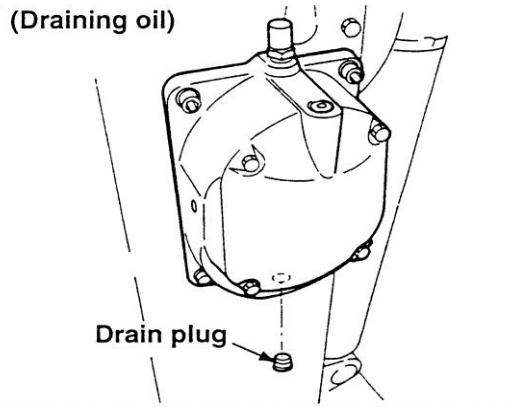

As air can enter the gearbox casings it may bring dust and debris with it

In addition moving machinery creates its own debris as it operates, no matter how well lubricated

Therefore replace oil in both gearboxes 6 months or 250 hours after bringing the vehicle into operation

Thereafter replace the gear oil

- Once every 12 months (1000 hours) for winch reduction gears
- Once every 24 month (2000 hours) for slew reduction gears

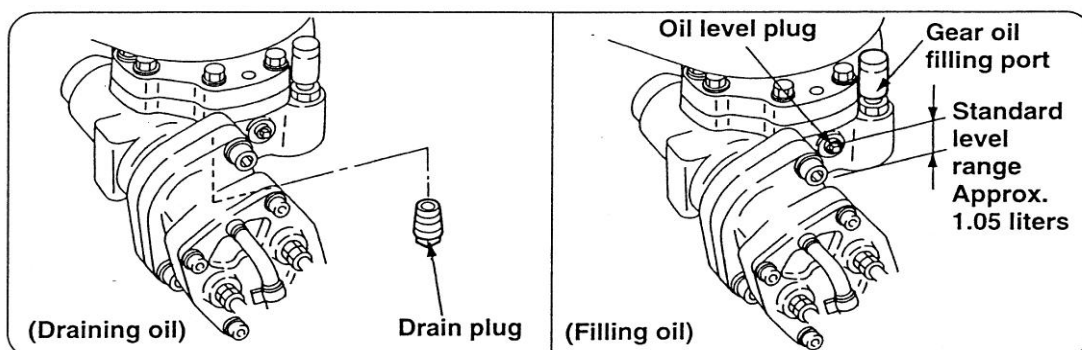
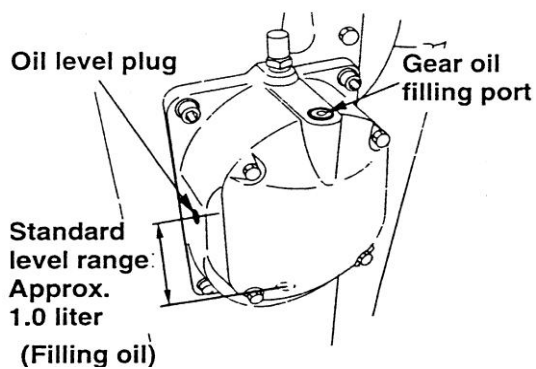

URW 706

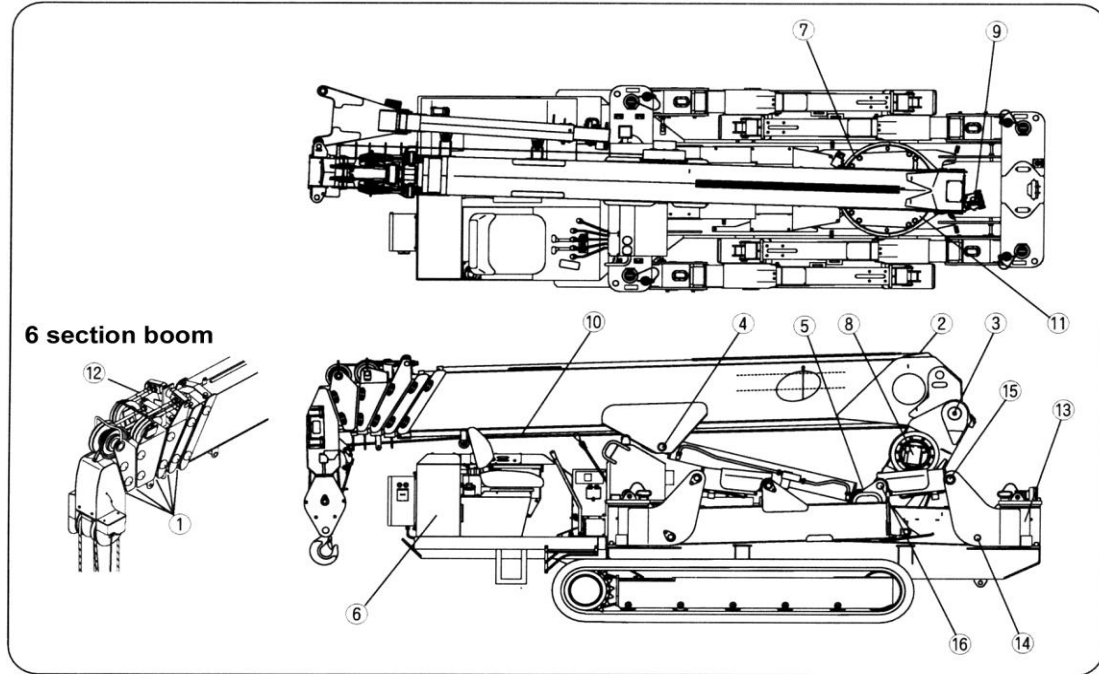

c. **Crane lubrication chart**

Service Interval	Where to lubricate	Nº of Parts	Lubricant	Tool
Daily	1 Boom slide plate (Underside and side face of boom extensions ②③④⑤⑥ for 6 section booms	5	Molybdenum grease	Manually
	2 Boom slide plate (Upper side of boom section ① )	2	Molybdenum grease	Grease gun
	3 Boom foot pin	1	Chassis grease	Grease gun
	4 Upper derrick cylinder support pin	1	Chassis grease	Grease gun
	5 Lower derrick cylinder support pin	1	Chassis grease	Grease gun
	6 Oil tank	1	Hydraulic oil	Manual
Weekly	7 Slewing gears	1	Chassis grease	Manual
Monthly	8 Winch reduction gears (approx. 1,0 litre)	1	Gear oil	Spray gun Grease gun Spray gun Grease gun Grease gun Grease gun Grease gun
	9 Slew reduction gears (approx. 0,7 litre)	1	Gear oil	
	10 Wire rope	1	Rope grease	
	11 Slew bearings	2	Chassis grease	
	12 Wire rope for boom extension	1	Rope grease	
	13 Outrigger fulcrum pin	4	Chassis grease	
	14 Outer box support	4	Chassis grease	
	15 Outrigger vertical cylinder (Bracket side)	4	Chassis grease	
16 Outrigger vertical cylinder (Outer box side)	4	Chassis grease		

### Replacing winch reduction gear oil

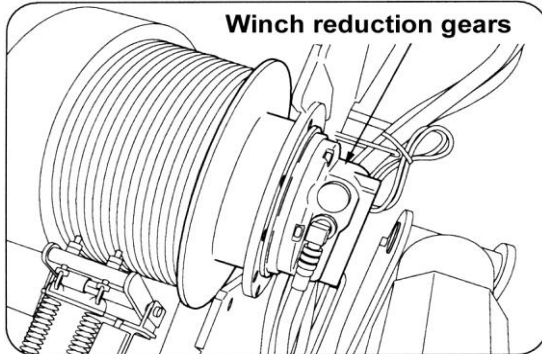

Remove winch hoist cover.  
Align fill and drain holes as shown below.  
Remove both plus and allow oil to drain fully.  
Plug drain port  
Pour specified quantity (1,4 litres) of gear oil into the filling port.  
Replace plug in filling port

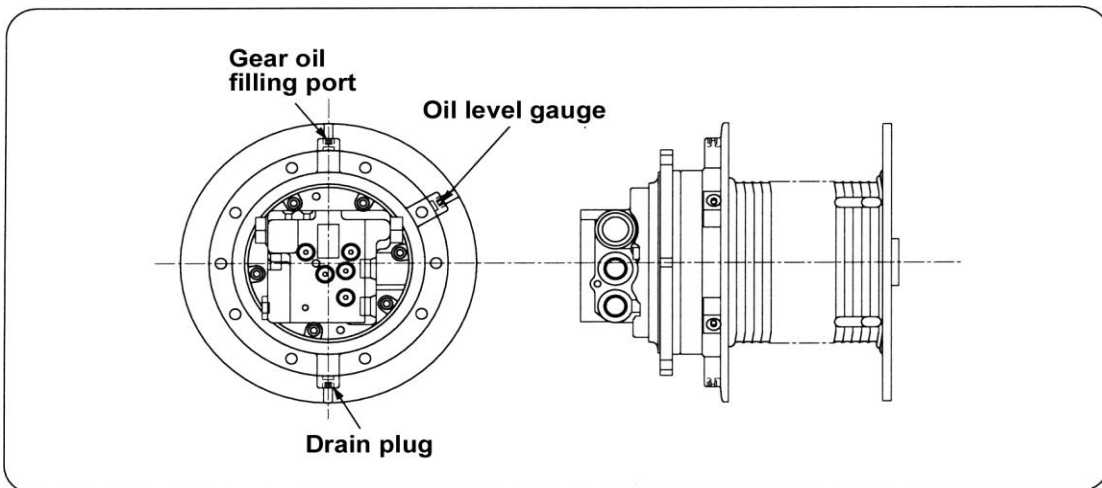

### Replacing slew reduction gear oil

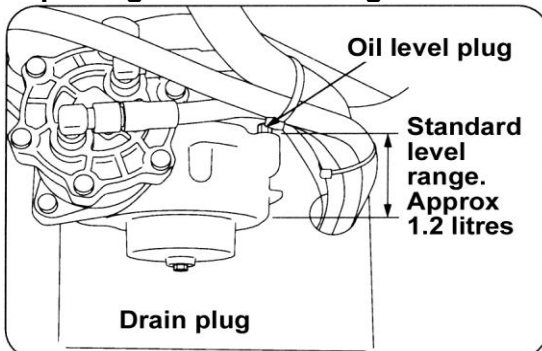

As air enters the casing it brings dirt and moisture with it.  
In addition moving parts wear and create metallic particles that may damage moving parts and seals.

Initially change gear oil after first 6 months of operation.

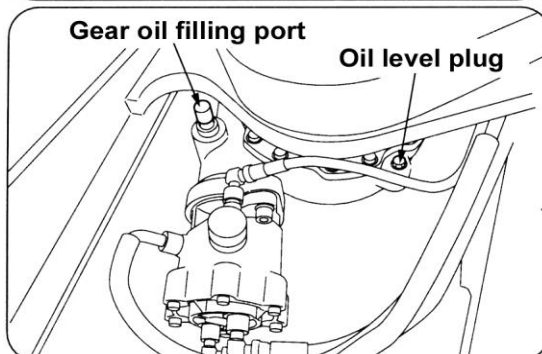

After that replace gear oil:

Once a year for winch reduction gears;

Once every 2 years for slew reduction gears.

Ensure gear oil for winch reduction gearbox reaches the middle of the oil gauge window.

ii. Lubrication of slew bearings and wire rope

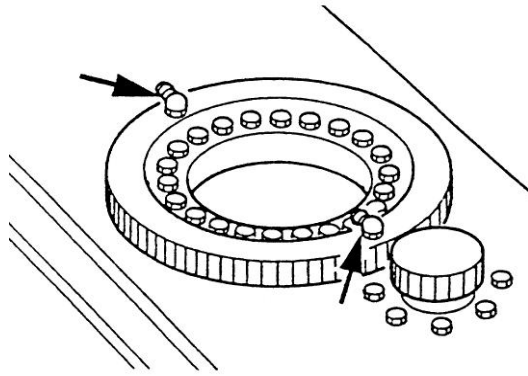

The slew ring employs a ball race as its bearing surface

Grease the bearings once a month during moderate operation and once a week during heavy operation

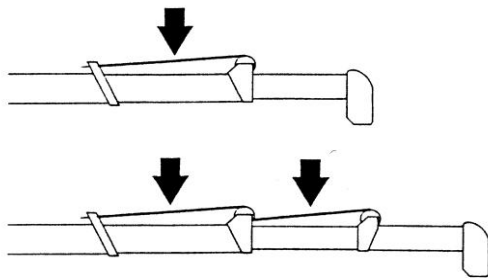

Apply grease to the boom extension ropes once a month, ensuring the boom is fully extended



**Intentionally Blank**





16. **SPECIFICATIONS**

a. **URW 376C**

<b>TECH SPEC</b>	
<b>Crane capacity</b>	capacity: 2,9t x 2,5m
<b>Max working radius</b>	max: 14,45m
<b>Max lifting height</b>	approx: 14,9m
<b>Dimensions</b>	folded: 4340mm (l) x 1300mm (w) x 1800mm (h)
<b>Weight</b>	unladen: URW 376C 3850kg (4000kg with electric option)
<b>Point loadings</b>	Due to the many variables, point loadings are only available on request
<b>Hook speed</b>	approx: 17m/min with 4 layers and 4 falls
<b>Telescopic system</b>	boomlength: 3,63 ~ 14,61m telescoping speed: 10,98m/23 seconds boom type: 6 section hydraulically telescoping boom, hexagonal box construction
<b>Derricking angle/speed</b>	approx: 0-80°/10 seconds
<b>Slewing angle/speed</b>	approx: 360° (continuous) 2.5 min <sup>-1</sup> (rpm)
<b>Traction system</b>	drive: hydrostatic 2 speed forward and reverse travel speed: 0 ~ 3km/h gradeability: 23° track ground length: 1750mm track ground pressure: 36kPa (0,37kg/cm <sup>2</sup> ) track width: 300mm
<b>Engine (Mitsubishi)</b>	fuel: diesel with electric option maximum output: 18,0kW (24.5PS)/2100 <sup>-1</sup> (rpm) starting method: electric tank capacities: 40 litres
<b>Standard equipment</b>	standard equipment: computer controlled rated capacity indicator, radio remote control, intelligent voice warning system, overload warning lamps
<b>Optional equipment</b>	optional equipment: 2 fall block, 1 fall block, cable remote control, low marking tracks, electric power option

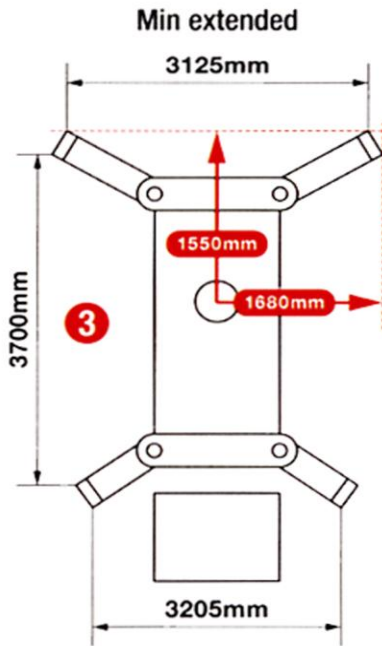
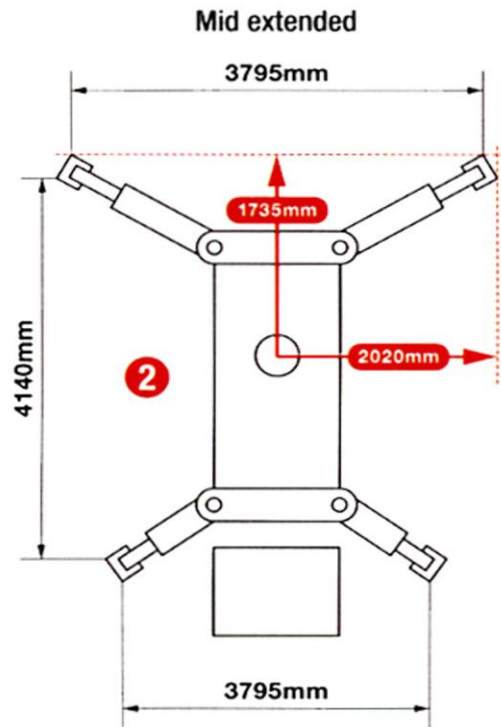
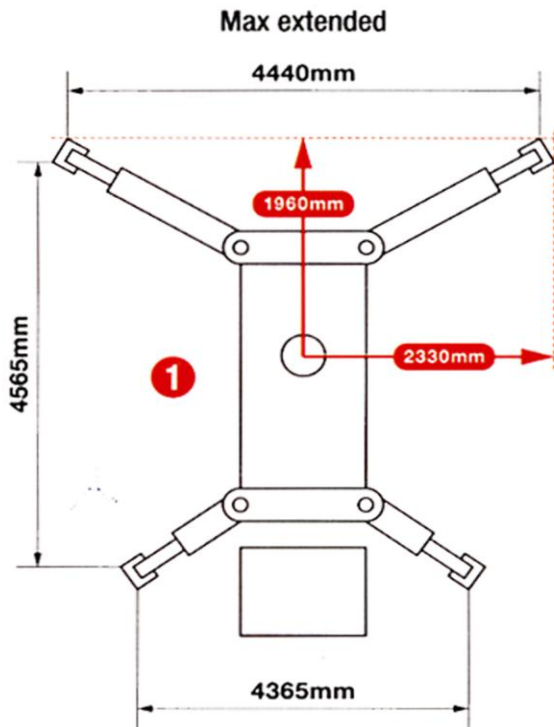

Outrigger positions

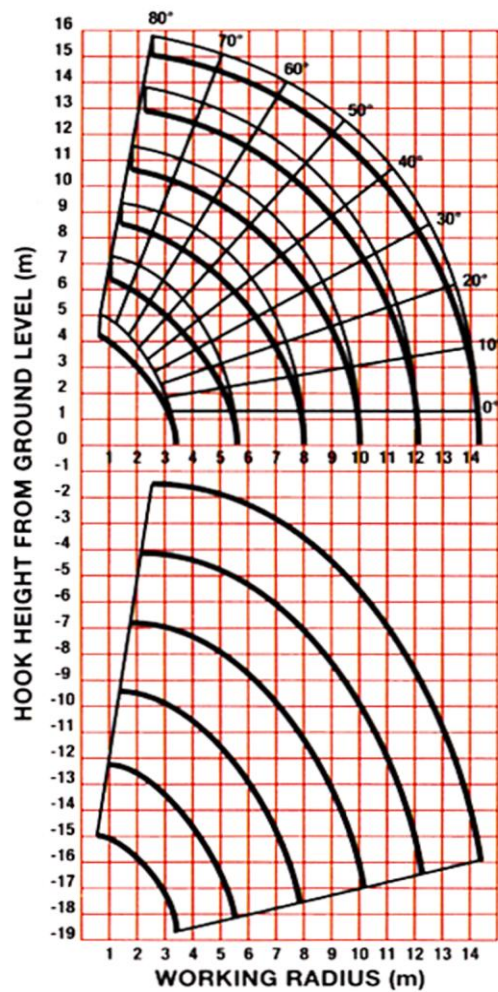
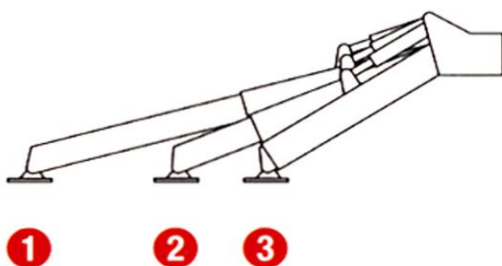

Boom Height      Hook Height



**Rated Load Chart URW 376C**

**Boom Extension: 1, 1+2**

Working Radius (m)		2,0	2,5	3,0	3,5	4,0	4,5	5,0	5,69
Rated Load (t)	Outriggers extended to Maximum	2,9	2,9	2,35	1,95	1,67	1,45	1,3	1,07
	Outriggers extended to Intermediate	2,9	2,9	2,32	1,92	1,57	1,25	0,99	0,77
	Outriggers extended to Minimum	2,9	2,9	2,17	1,5	1,12	0,9	0,72	0,47

**Boom Extension: 1+2+3**

Working Radius (m)		2,7	3,0	3,5	4,0	4,5	5,0	5,5	6,0	7,0	7,88
Rated Load (t)	Outriggers extended to Maximum	2,24	2,09	1,65	1,4	1,22	1,07	0,95	0,84	0,69	0,59
	Outriggers extended to Intermediate	2,24	2,06	1,65	1,39	1,17	1,0	0,82	0,64	0,45	0,37
	Outriggers extended to Minimum	2,24	2,06	1,57	1,22	1,02	0,83	0,65	0,51	0,3	0,19

**Boom Extension: 1+2+3+4**

Working Radius (m)		4,0	4,5	5,0	6,0	7,0	8,0	9,0	10,07
Rated Load (t)	Outriggers extended to Maximum	1,04	0,93	0,84	0,73	0,62	0,52	0,47	0,38
	Outriggers extended to Intermediate	1,03	0,92	0,83	0,67	0,5	0,38	0,28	0,2
	Outriggers extended to Minimum	1,03	0,82	0,64	0,47	0,31	0,22	0,13	0,09

**Boom Extension: 1+2+3+4+5**

Working Radius (m)		4,5	5,0	6,0	7,0	8,0	9,0	10,0	11,0	12,26
Rated Load (t)	Outriggers extended to Maximum	0,75	0,62	0,48	0,39	0,34	0,3	0,27	0,24	0,23
	Outriggers extended to Intermediate	0,75	0,62	0,47	0,39	0,32	0,27	0,22	0,17	0,13
	Outriggers extended to Minimum	0,75	0,62	0,4	0,25	0,18	0,13	0,09	0,06	0,01

**Boom Extension: 1+2+3+4+5+6**

Working Radius (m)		4,9	5,5	6,0	7,0	8,0	9,0	10,0	11,0	12,0	13,0	14,45
Rated Load (t)	Outriggers extended to Maximum	0,3	0,27	0,25	0,22	0,2	0,18	0,16	0,14	0,13	0,11	0,1
	Outriggers extended to Intermediate	0,3	0,27	0,25	0,22	0,2	0,18	0,16	0,12	0,09	0,06	0,04
	Outriggers extended to Minimum	0,3	0,27	0,25	0,22	0,17	0,11	0,08	0,05	0,03	0,02	0,01



**Intentionally Blank**



**b. URW 506C**

<b>TECH SPEC</b>	
<b>Crane capacity</b>	capacity: 3,0t x 3,4m
<b>Max working radius</b>	max: 15,52m
<b>Max lifting height</b>	approx: 16m
<b>Dimensions</b>	folded: 4800mm (l) x 1400mm (w) x 2035mm (h)
<b>Weight</b>	unladen: URW 506C 4840kg (4990kg with electric option)
<b>Point loadings</b>	Due to the many variables, point loadings are only available on request
<b>Hook speed</b>	approx: 17m/min with 4 layers and 4 falls
<b>Telescopic system</b>	boomlength: 3,93 ~ 15,71m telescoping speed: 11,78m/35 seconds boom type: 6 section hydraulically telescoping boom, hexagonal box construction
<b>Derricking angle/speed</b>	approx: 0-80°/18 seconds
<b>Slewing angle/speed</b>	approx: 360° (continuous) 2.5 min <sup>-1</sup> (rpm)
<b>Traction system</b>	drive: hydrostatic 2 speed forward and reverse travel speed: 0 ~ 3km/h gradeability: 23° track ground length: 1750mm track ground pressure: 45,1kPa (0,46kg/cm <sup>2</sup> ) track width: 300mm
<b>Engine (Mitsubishi)</b>	fuel: diesel with electric option maximum output: 18kW (24.5PS)/2100 <sup>-1</sup> (rpm) starting method: electric tank capacities: 40 litres
<b>Standard equipment</b>	standard equipment: computer controlled rated capacity indicator, radio remote control, intelligent voice warning system, overload warning lamps
<b>Optional equipment</b>	optional equipment: 2 fall block, 1 fall block, cable remote control, low marking tracks, electric power option



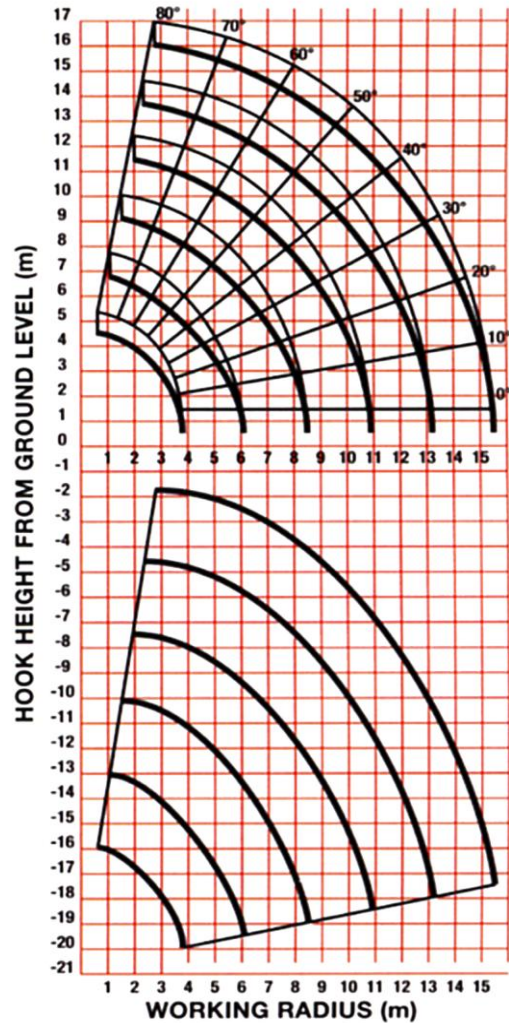
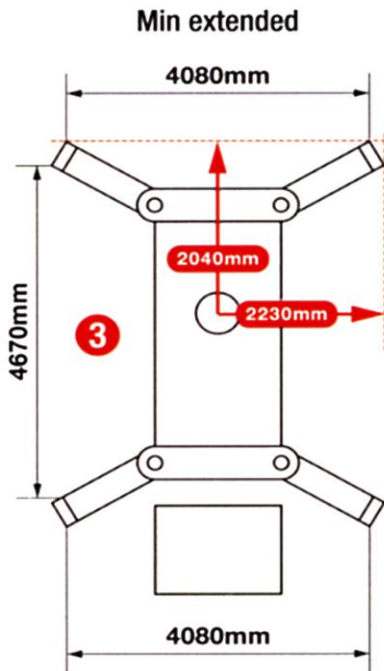
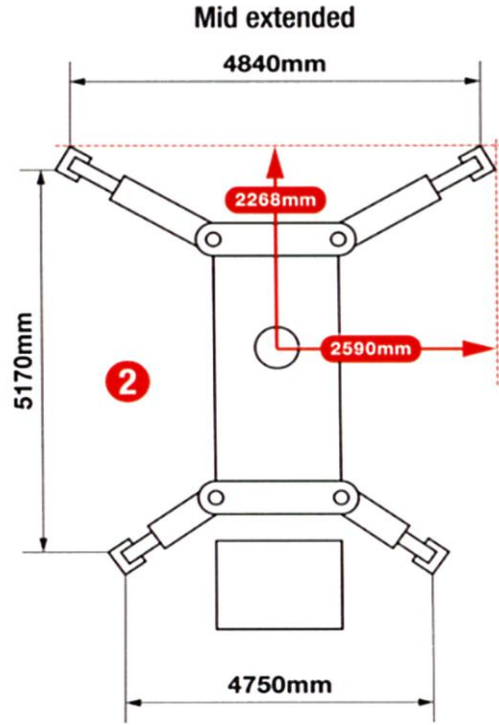
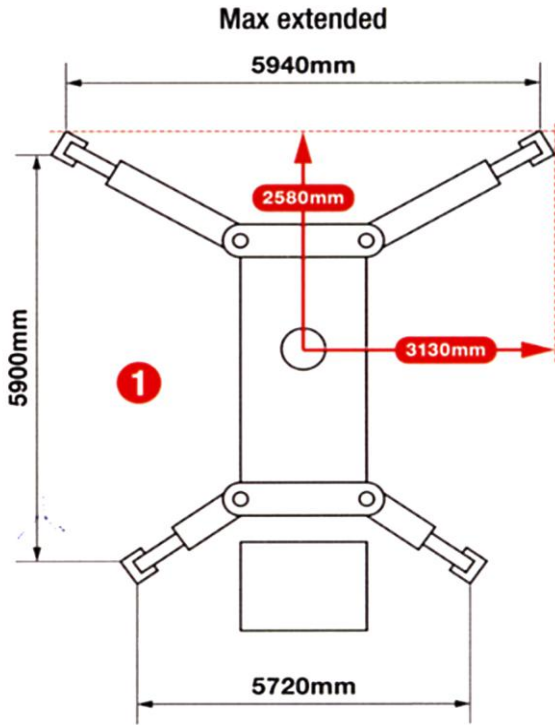

**Outrigger positions**

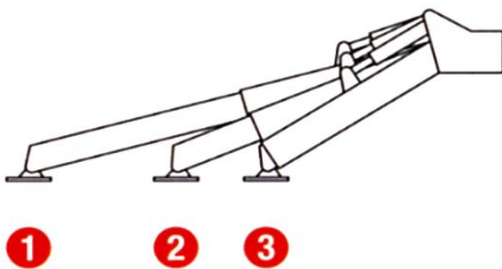

Boom Height

Hook Height





**Rated Load Chart URW 506C & URW 506-1 (4 t maximum capacity)**

Boom Extension: 1, 1+2, 1+2+3

Working Radius (m)		3,0	3,4	4,0	4,5	5,0	5,5	6,0	6,5	7,0	7,5	8,53
Rated Load (t)	Outriggers extended to Maximum	3,0 4,0	3,0 3,35	2,4	2,1	1,85	1,7	1,55	1,4	1,3	1,2	1,0
	Outriggers extended to Intermediate	3,0 4,0	3,0 3,35	2,4	2,1	1,85	1,7	1,4	1,2	1,05	0,85	0,62
	Outriggers extended to Minimum	3,0 4,0	3,0 3,35	2,4	2,0	1,65	1,35	1,1	0,9	0,75	0,6	0,45

Boom Extension: 1+2+3+4

Working Radius (m)		4,0	4,5	5,0	5,5	6,0	7,0	8,0	9,0	10,0	10,86
Rated Load (t)	Outriggers extended to Maximum	2,0	1,8	1,6	1,45	1,3	1,1	0,95	0,85	0,75	0,64
	Outriggers extended to Intermediate	2,0	1,8	1,6	1,45	1,3	1,05	0,7	0,6	0,45	0,39
	Outriggers extended to Minimum	2,0	1,8	1,6	1,35	1,1	0,75	0,5	0,4	0,3	0,25

Boom Extension: 1+2+3+4+5

Working Radius (m)		5,0	5,5	6,0	7,0	8,0	9,0	10,0	11,0	12,0	13,19
Rated Load (t)	Outriggers extended to Maximum	1,0	0,92	0,85	0,7	0,6	0,55	0,5	0,45	0,4	0,35
	Outriggers extended to Intermediate	1,0	0,92	0,85	0,7	0,6	0,52	0,45	0,39	0,3	0,25
	Outriggers extended to Minimum	1,0	0,92	0,85	0,7	0,5	0,4	0,3	0,25	0,2	0,17

Boom Extension: 1+2+3+4+5+6

Working Radius (m)		6,0	7,0	8,0	9,0	10,0	11,0	12,0	13,0	14,0	15,52
Rated Load (t)	Outriggers extended to Maximum	0,5	0,4	0,35	0,3	0,25	0,25	0,2	0,2	0,15	0,15
	Outriggers extended to Intermediate	0,5	0,4	0,35	0,3	0,25	0,25	0,2	0,2	0,15	0,15
	Outriggers extended to Minimum	0,5	0,4	0,35	0,3	0,25	0,23	0,2	0,17	0,15	0,1



**Intentionally Blank**



c. URW 706C

<b>TECH SPEC</b>	
<b>Crane capacity</b>	capacity: 6,0t x 3,0m
<b>Max working radius</b>	max: 18,6m
<b>Max lifting height</b>	approx: 19,5m (22,7m with extension jib)
<b>Dimensions</b>	folded: 5610mm (l) x 1600mm (w) x 2185mm (h)
<b>Weight</b>	unladen: URW 706CDR 7920kg URW 706CDRM 8070kg
<b>Point loadings</b>	Due to the many variables involved, point loading information only available on request
<b>Hook speed</b>	approx: 11m/min with 4 layers and 4 falls
<b>Telescopic system</b>	boomlength: 4,80 ~ 19,20m telescoping speed: 14,4m/52 seconds boom type: 6 section hydraulically telescoping boom, hexagonal box construction
<b>Derricking angle/speed</b>	approx: 0-80°/16 seconds
<b>Slewing angle/speed</b>	approx: 360° (continuous) 2.5 min <sup>-1</sup> (rpm)
<b>Traction system</b>	drive: hydrostatic 2 speed forward and reverse travel speed: 0 ~ 3km/h gradeability: 23° track ground length: 2240mm track ground pressure: 87,2kPa (0,89kg/cm <sup>2</sup> ) track width: 400mm
<b>Engine</b>	fuel: diesel with electric option maximum output: 23,5kW (32PS)/2500 <sup>-1</sup> (rpm) starting method: electric tank capacities: 74 litres
<b>Standard equipment</b>	standard equipment: computer controlled rated capacity indicator, radio remote control, intelligent voice warning system, overload warning lamps, stowable extension jib
<b>Optional equipment</b>	optional equipment: Searcher hook, 7.5kW electric power pack (400V 3 phase), 1 fall and 2 fall blocks, low marking track



## Outrigger Positions

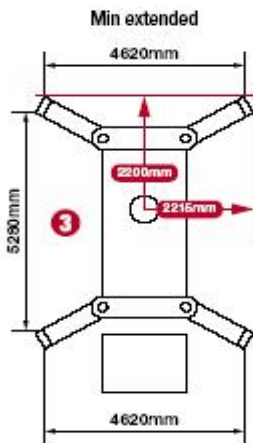
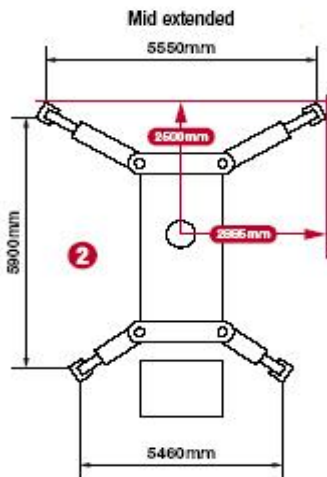
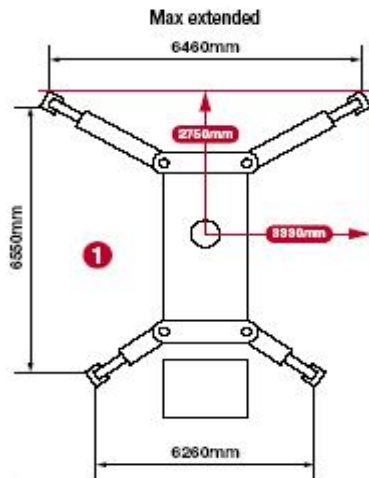
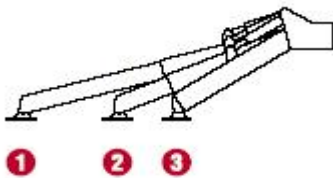

## Rated Loads

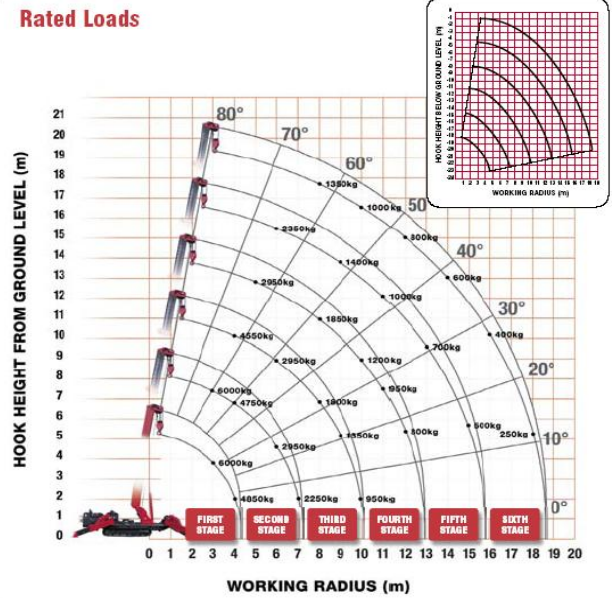



**Rated Load Chart URW 706C**

Boom Extension: 1

Working Radius (m)		2,7	3,0	3,5	4,0	4,3
Rated Load (t)	Outriggers extended to Maximum	6,0	6,0	5,45	4,85	3,95
	Outriggers extended to Intermediate	6,0	6,0	5,45	4,85	3,95
	Outriggers extended to Minimum	6,0	6,0	5,45	4,55	3,75

Boom Extension: 1+2

Working Radius (m)		2,0	3,0	3,5	4,0	5,0	6,0	7,0	7,2
Rated Load (t)	Outriggers extended to Maximum	6,0	6,0	5,35	4,75	3,75	2,95	2,25	2,0
	Outriggers extended to Intermediate	6,0	6,0	5,35	4,75	3,75	2,45	1,7	1,55
	Outriggers extended to Minimum	6,0	6,0	5,35	4,65	2,55	1,65	1,15	1,05

Boom Extension: 1+2+3

Working Radius (m)		2,7	4,0	5,0	6,0	7,0	8,0	9,0	10,0	10,1
Rated Load (t)	Outriggers extended to Maximum	4,55	4,55	3,65	2,95	2,4	1,8	1,35	0,95	0,95
	Outriggers extended to Intermediate	4,55	4,55	3,65	2,95	1,75	1,3	0,95	0,7	0,7
	Outriggers extended to Minimum	4,55	4,55	2,65	1,7	1,2	0,85	0,65	0,45	0,4

Boom Extension: 1+2+3+4

Working Radius (m)		5,0	6,0	7,0	8,0	9,0	10,0	11,0	12,0	12,9
Rated Load (t)	Outriggers extended to Maximum	2,95	2,55	2,15	1,85	1,5	1,2	0,95	0,8	0,45
	Outriggers extended to Intermediate	2,95	2,55	1,85	1,4	1,1	0,85	0,65	0,55	0,4
	Outriggers extended to Minimum	2,75	1,85	1,3	1,0	0,75	0,55	0,43	0,33	0,24

Boom Extension: 1+2+3+4+5

Working Radius (m)		6,0	8,0	9,0	10,0	11,0	12,0	13,0	14,0	15,0	15,8
Rated Load (t)	Outriggers extended to Maximum	2,35	1,7	1,4	1,2	1,0	0,85	0,7	0,6	0,5	0,4
	Outriggers extended to Intermediate	2,35	1,5	1,15	0,95	0,75	0,6	0,5	0,4	0,3	0,25
	Outriggers extended to Minimum	1,95	1,05	0,8	0,65	0,5	0,4	0,3	0,23	0,17	0,13

Boom Extension: 1+2+3+4+5+6

Working Radius (m)		8,0	10,0	12,0	14,0	16,0	18,0	18,6
Rated Load (t)	Outriggers extended to Maximum	1,35	1,0	0,8	0,6	0,4	0,25	0,2
	Outriggers extended to Intermediate	1,35	1,0	0,65	0,45	0,3	0,2	0,15
	Outriggers extended to Minimum	1,1	0,7	0,45	0,28	0,17	0,09	0,06



**Rated Load chart for Extension Jib**

Angle/Rated Boom Angle	Net Rated Load (kg) At Extension Jib Angle			
	0°	20°	40°	60°
80°	800	800	600	600
75°	800	800	600	600
70°	700	700	500	500
65°	600	600	400	400
60°	500	500	Prohibited	
55°	400	400		
50°	300	300		
40°	Prohibited			
30°				
20°				
10°				
0°	Prohibited			

**Rated Load chart for Searcher Hook**

Radius/Rated Load Working Radius (m)	Searcher Hook Net Rated Load (kg)				
	Outriggers Max Extension	Outriggers Mid Extension	Outriggers Min Extension		
7,0	800	800	800		
8,0	800	800	610		
9,0	800	700	420		
10,0	800	550	250		
10,5	800	490	200		
11,0	650	430	160		
11,5	550	370	120		
12,0	470	310	100		
13,0	330	230	Prohibited		
14,0	260	150			
15,0	210	100			
16,0	170	Prohibited			
17,0	130				
18,0	100				
20,8	Prohibited				





**d. Additional Information for Cranes with Electric Pack Option**

**Electrical Data**

Detail	URW376/506/706C
Power Output	7,5kW
Volts	AC400 ± 5%
Frequency	50/60Hz ± 5%
Phase	3
Cable size	2,00mm <sup>2</sup>
Earth (very important)	2,00mm <sup>2</sup>
Motor direction seen from motor shaft	left

**a. Before Operation**

**NEVER** open the Regulation Box when mains power is applied to the crane

1. The engine must be stopped and the starter key turned to OFF.
2. Press the (Green) ON button on the Regulation Box.
3. If the motor does not start, check the circuit breakers in the Regulation Box. In the case of reverse rotation: 2 of the side wires in the 3 phase plug must be swapped by a competent electrician.

**Regulation Box**

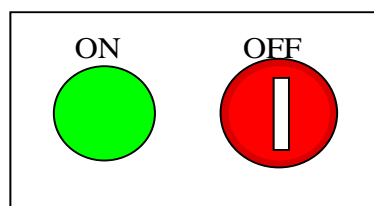

4. When the OFF button is pressed it can only be released by unlocking it with the key provided. This is to stop unauthorised use of the crane.
4. Confirm that the hydraulic system is working by lowering and raising the hook.
5. Confirm that the 12V DC for the Remote Control is available by checking that the Remote Control is working.



**b. During Operation**

1. When the crane is operating under electrical power, it is very quiet. The operator must ensure that all personnel in the area are made aware that the crane is working. He must remain observant throughout the operation.
2. The crane speed will be fixed when using the Electric Pack due to the constant speed of the output shaft.
3. When the crane is not working, turn OFF at the Regulation Box.

**c. After Operation**

1. Turn the electric motor off.
2. Remove the mains supply cable.

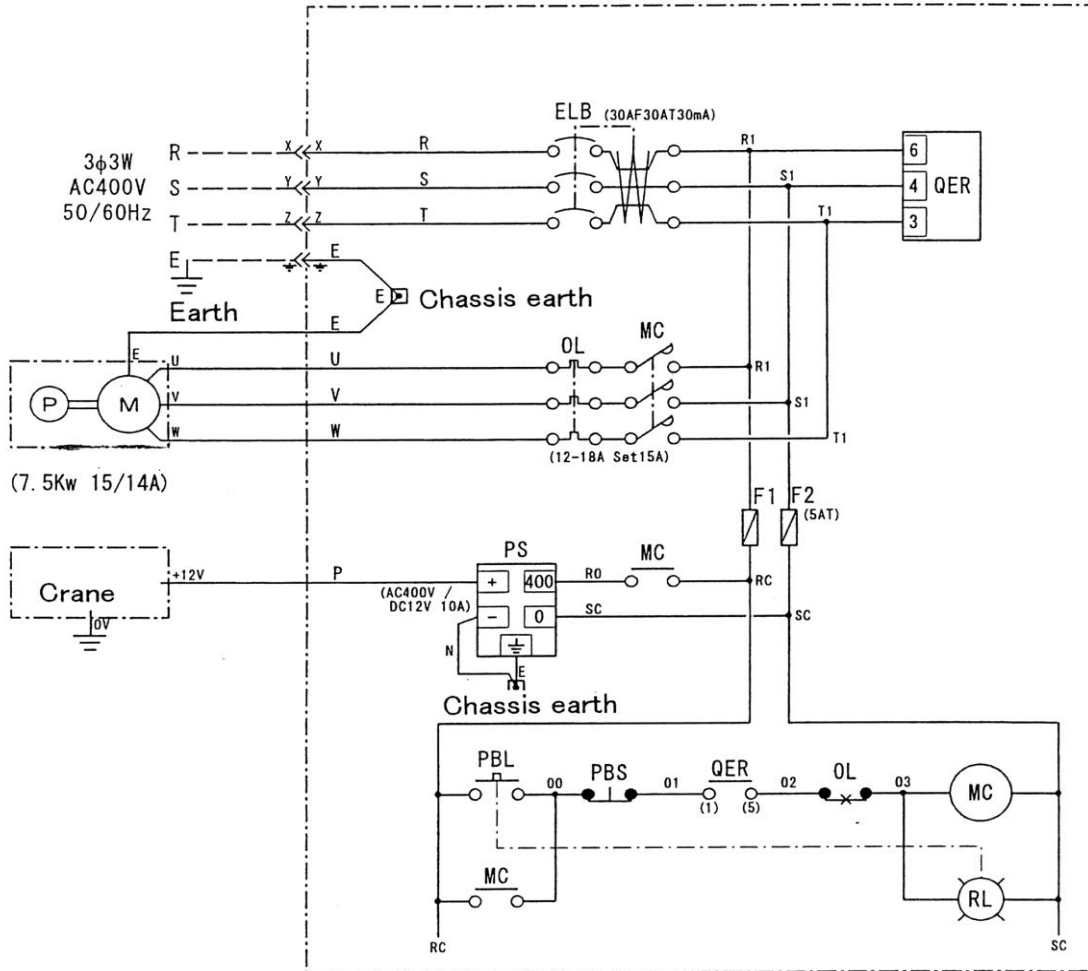

**URW 376C/506C**

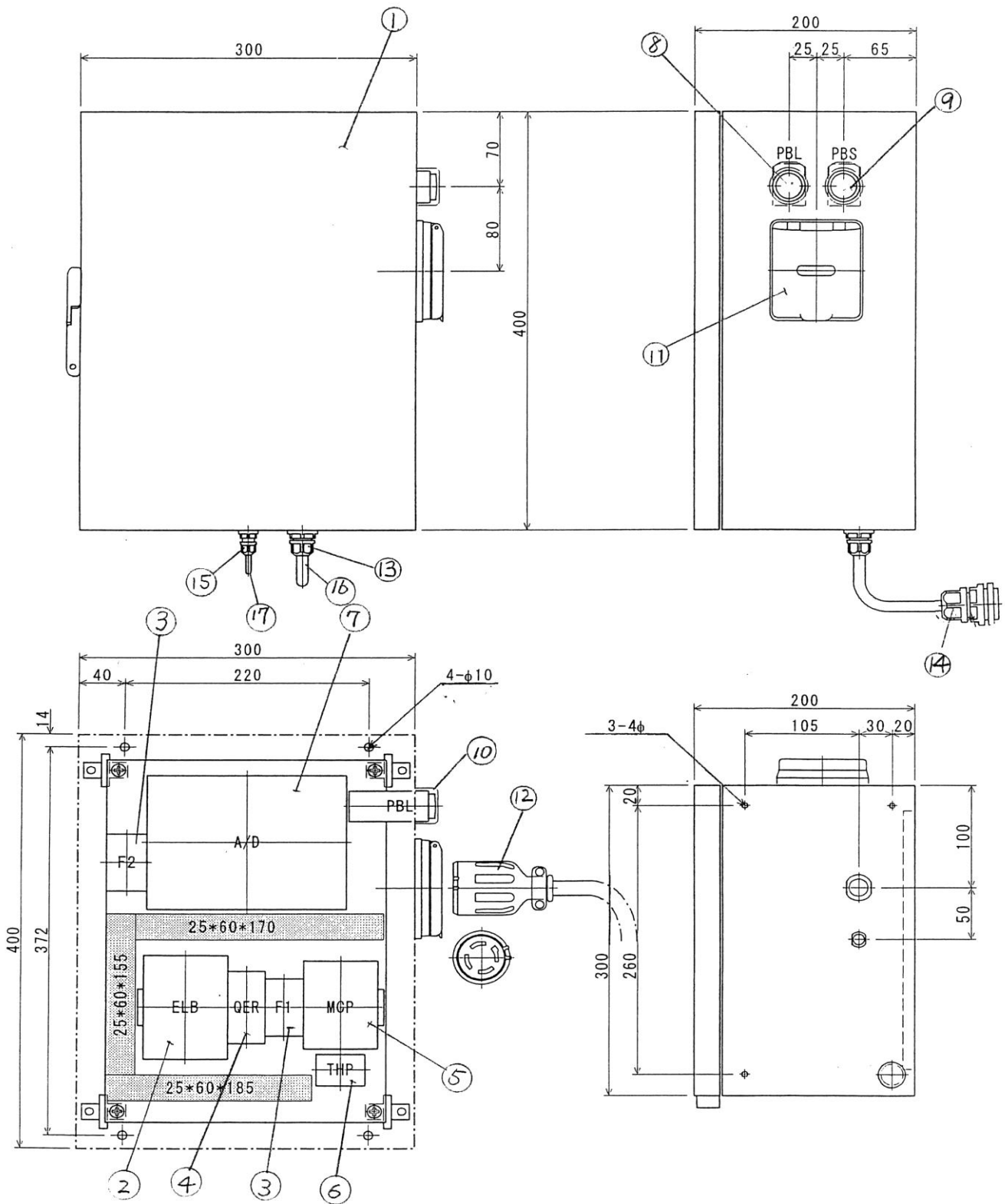

URW 376C/506C

## AC400V Hydraulic Circuit for 095/295/376/506

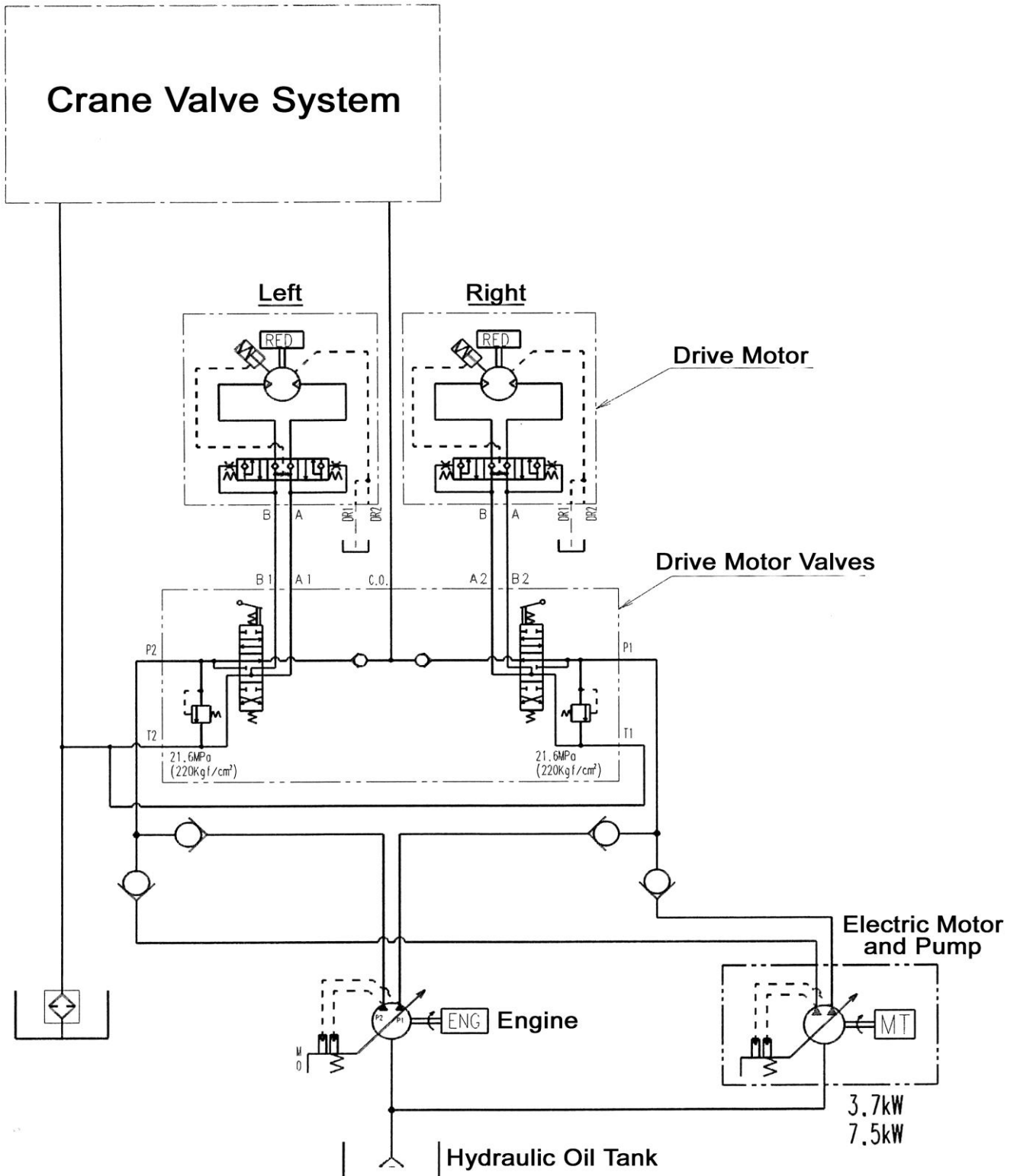



Parts List (URW 376 / 506 / 706 CRDM)

No	Symbol	Part Name	Part No	Type	Company	Qty
1		Regulation Box	750716010	CL20-34	Nittou	1
2	ELB	Earth Leakage Circuit Breaker	750319011	EG33C/30-3-MA	Fuji Electric	1
		Terminal Cover		BZ6TSH10C3	Fuji Electric	1
3	F1,2	Fuse	750309025	AFaC-5	Fuji Electric	2
		Terminal Cover		GC-30	Fuji Electric	2
4	QER	Right Rotation Relay	750307049	QE-40N	Fuji Electric	1
5	MCP	Magnetic Contactor	750319012	SC-05H/2a-AC400V	Fuji Electric	1
6	THP	Thermal Relay	750307051	Tk-5-1N/12A	Fuji Electric	1
		Terminal Cover		SZ-JW2	Fuji Electric	1
7	A/D	Converter	750111007	46904	Legrand	1
8	PBL	Light Switch Button	750303057	AR22EOL-10T3G	Fuji Electric	1
9	PB2	Switch Button	750303058	AR22EOR-01R	Fuji Electric	1
10		Waterproof Cap	750714001	AR9D797	Fuji Electric	2
11		Connector Inlet	750501210	4365NW	American	1
12		Connector Wire	750501211	4364R	American	1
13		Connector	750501212	OA-W1611	Ohom	1
14		Connector	750501213	OA-2	Ohom	1
15		Connector	750501214	OA-W15M07	Ohom	1
16		Wire	750604055	2PNCT 2,0sq 4c		1
17		Wire	750604056	2PNCT 1,25sq 1c		1



**e. Emergency lowering equipment (where fitted)**

Illustration 1 shows the kit of parts that makes up the emergency lowering equipment. A is the pump and removable handle. B is the ¼ inch (6.3mm) pipe for hydraulic supply. C is the ⅜ inch (9.5mm) pipe for hydraulic return. D is the adaptor used in the telescoping mode only. E is the return pipe adaptor. F is the supply adaptor fitted to the body of the pump

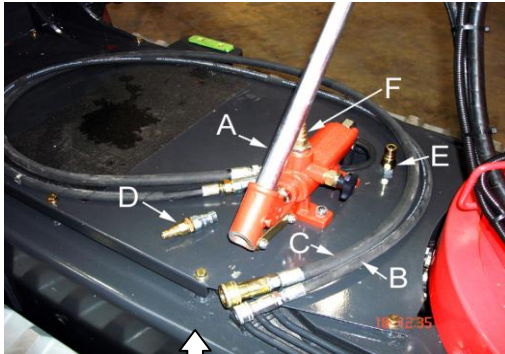

**Illustration 1**



**Illustration 3** showing crane ready for emergency telescoping. Note the telescoping adaptor (D) fitted to the line



**Illustration 2** showing pipes connected for normal crane telescoping operation supply



**Illustration 5** showing crane ready for emergency winching



**Illustration 4** showing pipes connected for normal crane winching operation

**a. Operation for telescoping and winching**

- i. Determine which action is required, winching or telescoping and fit pipes accordingly, with reference to the illustrations.
- ii. Fit the pump handle and tighten the black handwheel on the pump body.
- iii. Pump using the handle until crane is recovered.
- iv. Loosen the handwheel to release the pressure
- v. Remove the pipes and adaptors from their fittings and stow carefully, ensuring the ends are correctly covered to stop the entry of dirt or grit.
- vi. Remove and carefully stow the pump handle.
- vii. Return the crane to the nearest authorised UNIC centre for repair immediately.

**d. How to use Searcher Hook (URW 376 / 506)**

**1. How to set Searcher Hook**

	<p><b>Remove pin (20) and turn searcher hook around the round bar</b></p> <p><b>It is rotated until the searcher hook hangs to the top sheave Pin</b></p> <p><b>Searcher hook is pulled Obliquely upward, and turn searcher hook around the top sheave pin</b></p> <p><b>The pin (20) is inserted at the tilt angle that wants to be used. Put up the snap pin so as not to come off.</b></p>
--	--

## 2. How to store Searcher Hook

<p>Pin(20)</p>	<p><b>Remove pin (20) and turn searcher hook around the top sheave pin</b></p>
<p>Guide to Restore</p> <p>Round bar</p>	<p><b>Put the round bar on the notch of the guide</b></p>
<p>Round bar</p> <p>Searcher Hook</p>	<p><b>Remove the hook from the top sheave pin and around the round bar on searcher hook like this drawing</b></p>
<p>Rubber Band</p>	<p><b>Insert pin (20) into the hole for restore on bracket to be the store position. Fix the hook with the rubber hand during travelling</b></p>

**17 URW 506 ONLY DISASSEMBLY PROCEDURES**

**a. Weight of sub-assemblies**

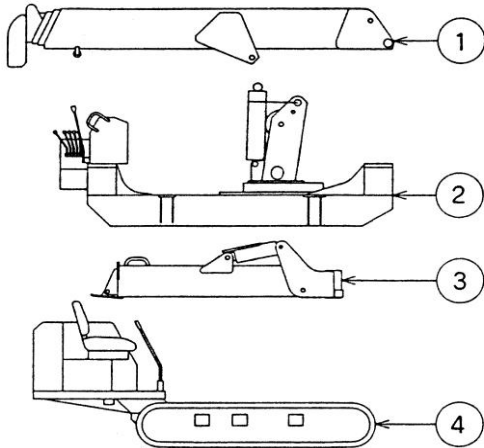

Boom	910kg
Frame	1460kg
Outriggers	1000kg (250kg x 4)
Carrier	1250kg

**b. Disassembly procedures**

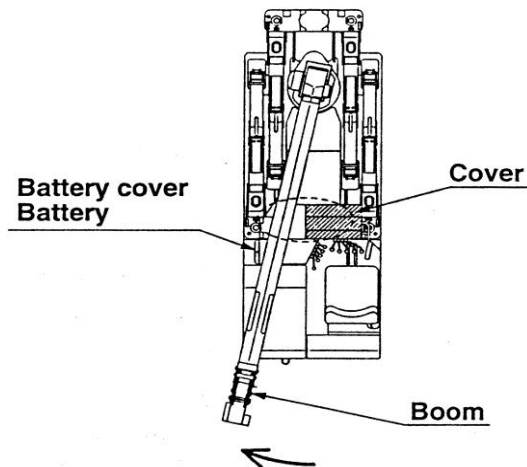

- In order to stop the boom from hitting the control cover, slew boom left a little before disassembling. Ground to hook to make removal easier.
- Remove the battery cover to detach battery
- Remove the hook to enable the wire rope to be removed from the boom



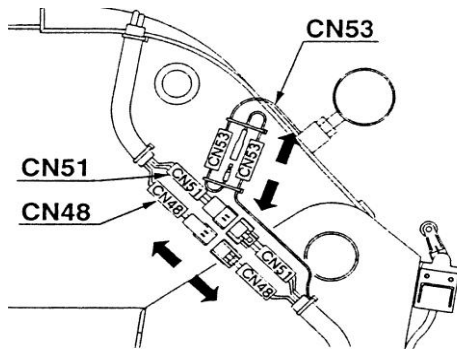

- Disconnect wiring harness for detection switches for boom length (CN48), boom angle (CN51) and alarm lamp (CN53).

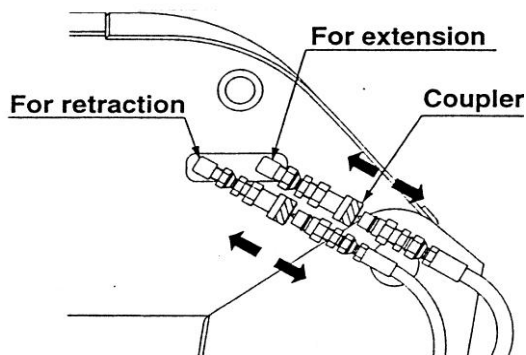

- Remove hoses to telescoping cylinder

- Fit a nylon sling of adequate capacity around the boom. Take up any slack and bear the weight of the boom. Remove the boom axis pin and lift the boom clear of the frame.

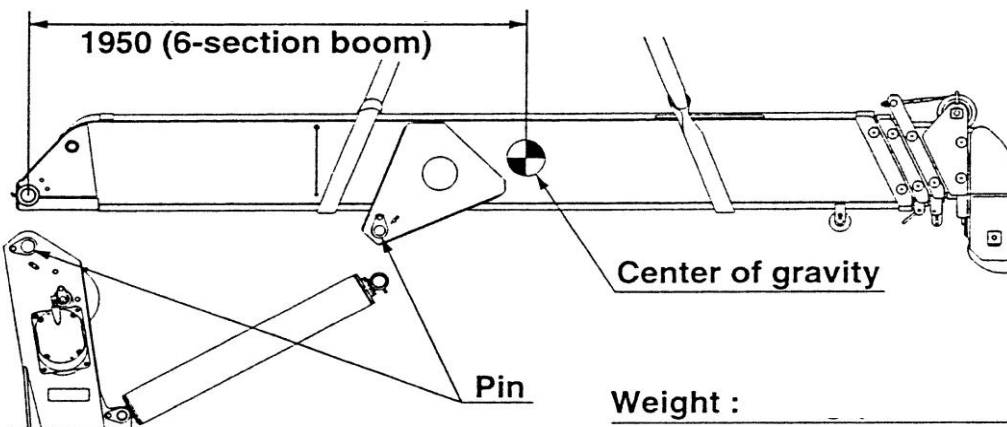

Weight :

910kg (6-section boom)



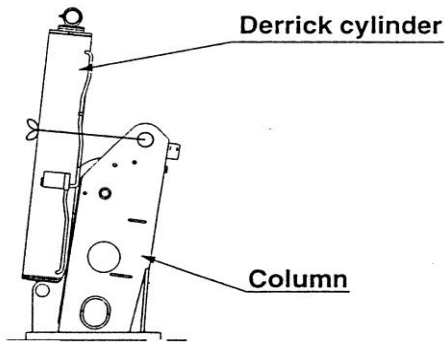

- Lift the derricking cylinder by hand and securely attach it to the column

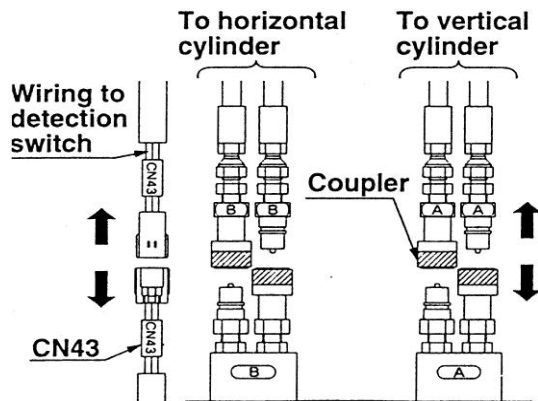

- Remove hoses to outrigger cylinders
- Remove wiring to detection switch (CN43)

- Fit a nylon sling of adequate capacity around the outrigger. Take up any slack and bear the weight of the outrigger. Remove the outrigger pin and remove the outrigger

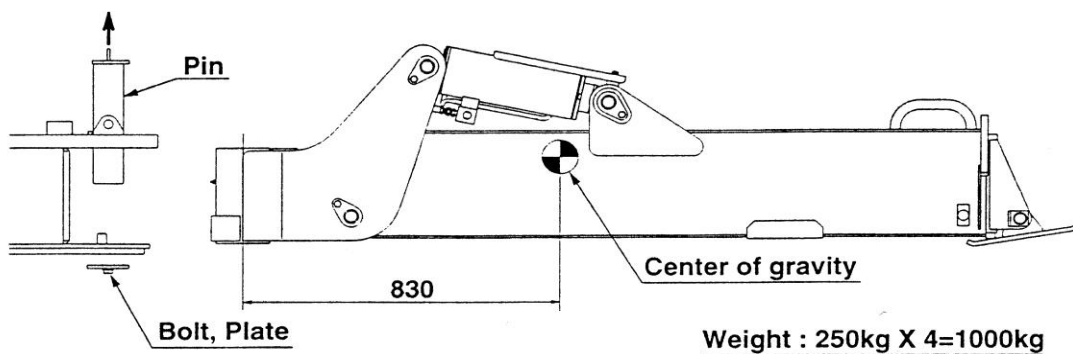

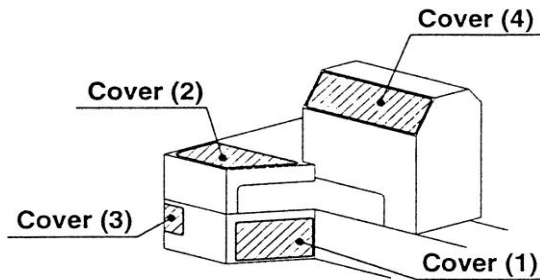

- Remove the cover (1) to disconnect the hose (for slewing locks) and drain hose

**NB**

Always open the tank line cock fully before disassembling. Starting the engine without opening the cock may damage the pump and hose

- Remove the wiring to the unloading valve

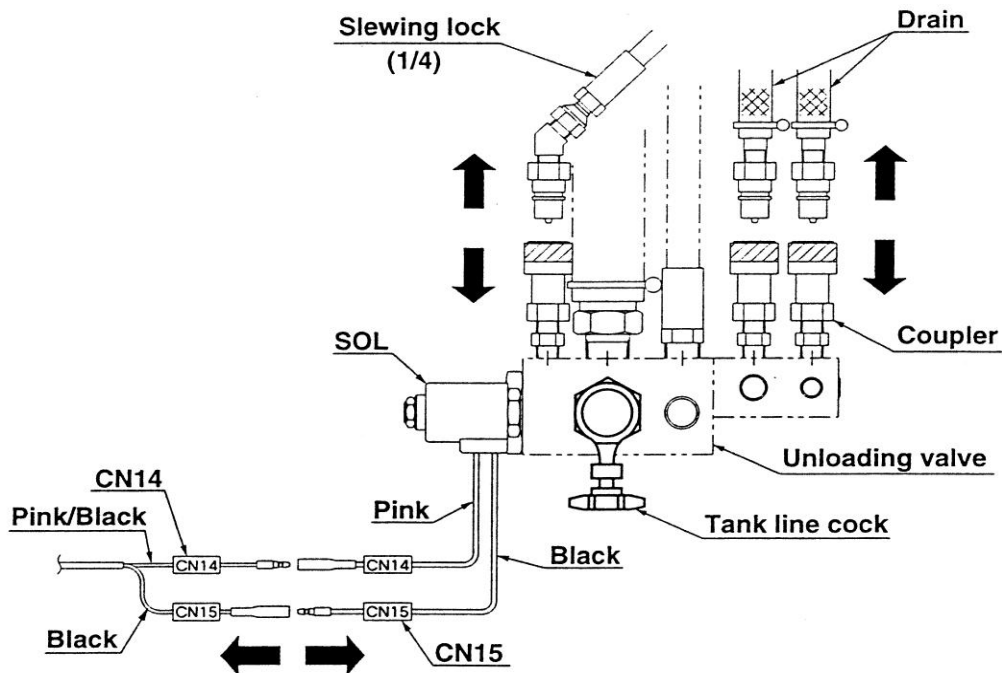



- Remove covers (2) and (3) to remove the high-pressure hoses. Fit hose plugs (items to be ordered) to the hose and elbow.
- Unfasten the hose clamp located on the top of the return hose (removing the frame helps extraction of the return hose).

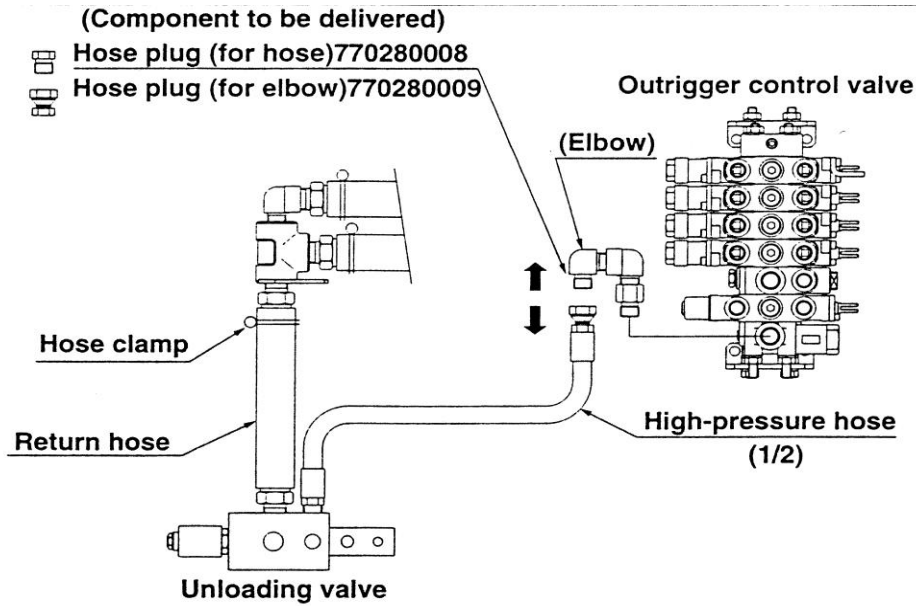

- Disconnect wiring harness to Crane-Crawl selector switch at the connector (CN13) which is located under the crawling levers by the foot space by the drivers seat.

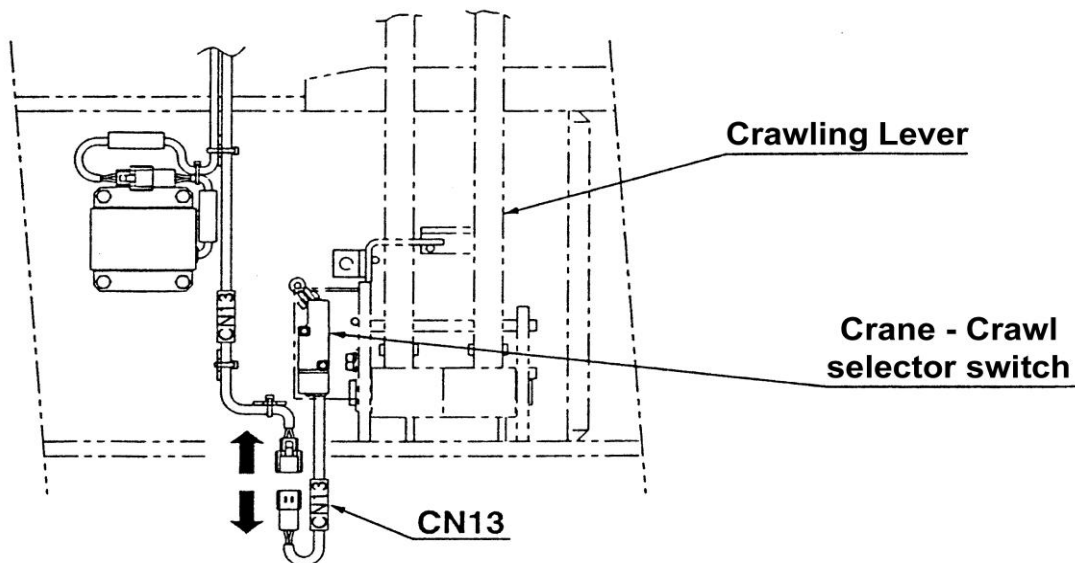



- Remove cover (4) to gain access to the rear of the fascia panel.
- Remove the starter switch from the cover and disconnect the wiring from the two pilot lamps and the hour meter
- Disconnect the wiring to the power supply at connector (CN16) and to the fuse block (fuse block is fixed to the inside of the cover)
- Pull the wiring harness back to the unloading valve

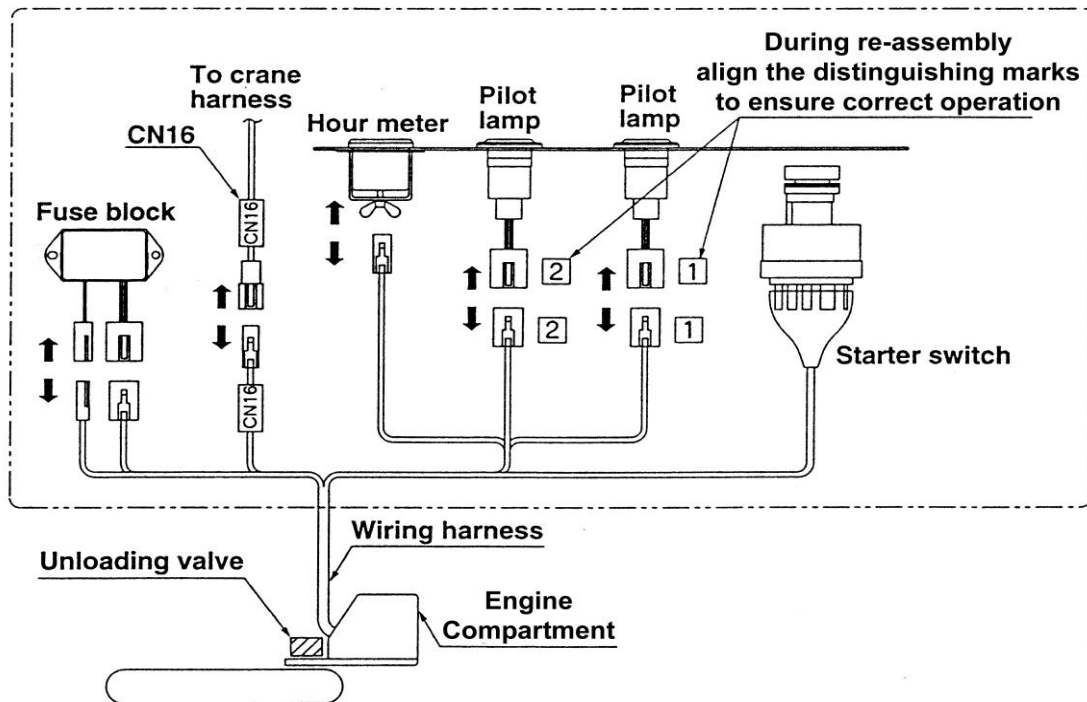
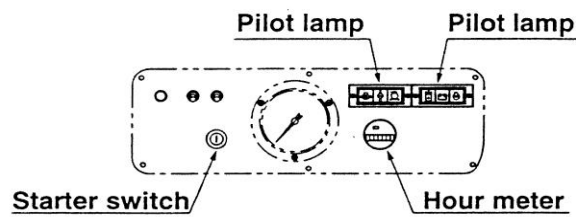

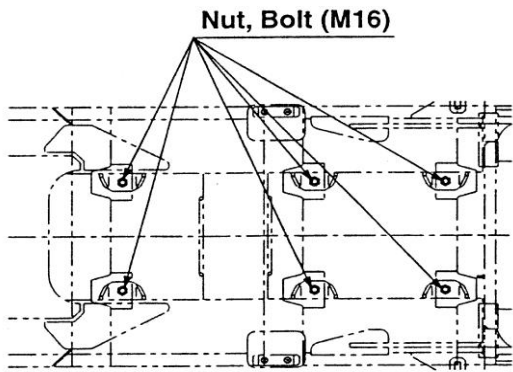

- Remove the cover attached to the top of the frame to expose the bolts fastening the frame to the carrier
- Remove the 6 bolts

**NB**

When reassembling ensure they are torqued to 186-225Nm (1900-2300kgf/cm or 137-166 ft/lbs)

- Attach wire rope multi-legged sling to the hook retainers at front and rear to lift the frame. Lifting the frame aids in removal of the return hose
- Quickly fit hose plug and hose plug assembly (items to be ordered) to the return hose connector (both crane and carrier side) to prevent leaks.
- Lower frame on to sturdy timbers laid on the ground. This prevents damage to the underside of the frame

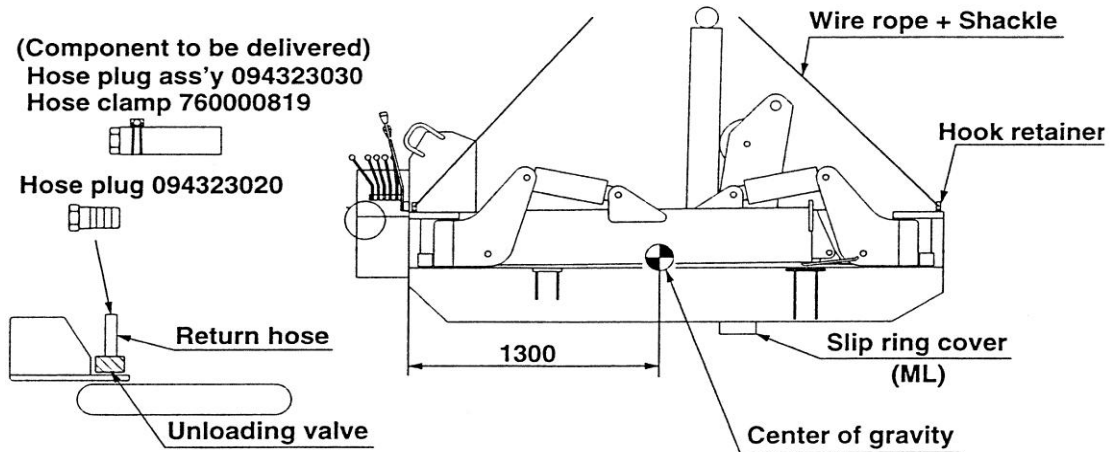



**DO NOT attempt to drive carrier while disassembled, this is EXTREMELY dangerous.  
DO NOT start the engine!**

- Lift up the carrier as illustrated below

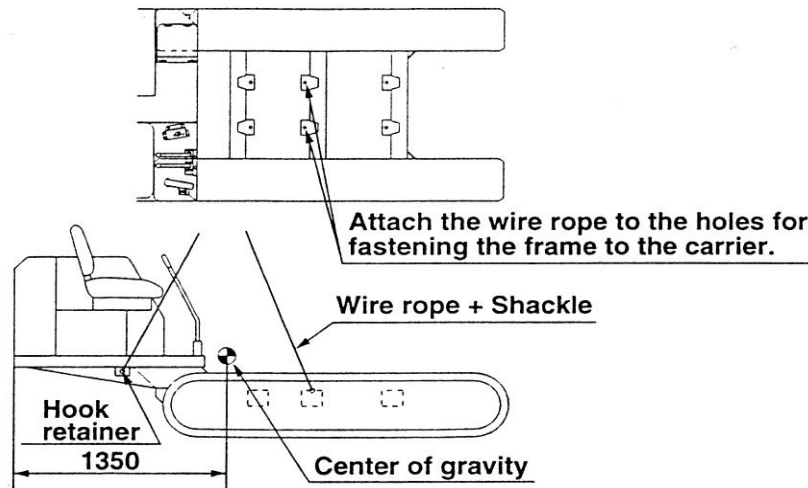



**c. Reassembly procedures**

- Torque for frame to carrier bolts is 186-225 Nm (1900-2300 kgf/cm or 137-166 ft/lbs)
- Drain hose can be connected to either one of the two unloading valve fittings but **NOT** the slewing lock fitting
- When fastening the nuts of the boom axis pin and the derricking cylinder pin apply Loctite 242 or equivalent
- When fastening the nuts of the outrigger pins, use Loctite 262 or equivalent
- Connect each hose coupler according to the marking on the stickers (A) and (B)
- Each outrigger should be mounted facing the switch cover plate
- When pumping up the track tension after reassembly always over tension and leave for an hour then adjust to normal tension
- After reassembly check the level in the hydraulic oil tank and top-up if necessary

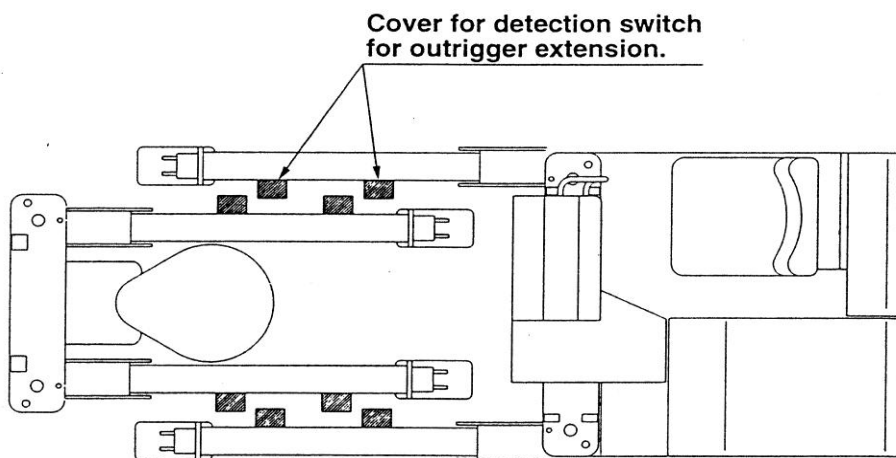



**d. Components to be ordered prior to disassembly**

Component Name	Part Number	Quantity
Hose Plug (for hose)	770280008	1
Hose Plug (for elbow)	770280009	1
Hose Plug	094323020	1
Hose Plug Assembly	094323030	1
Hose Clamp	760000819	1



18 **ADDITIONAL EQUIPMENT**

a. ***Description of Remote Control***

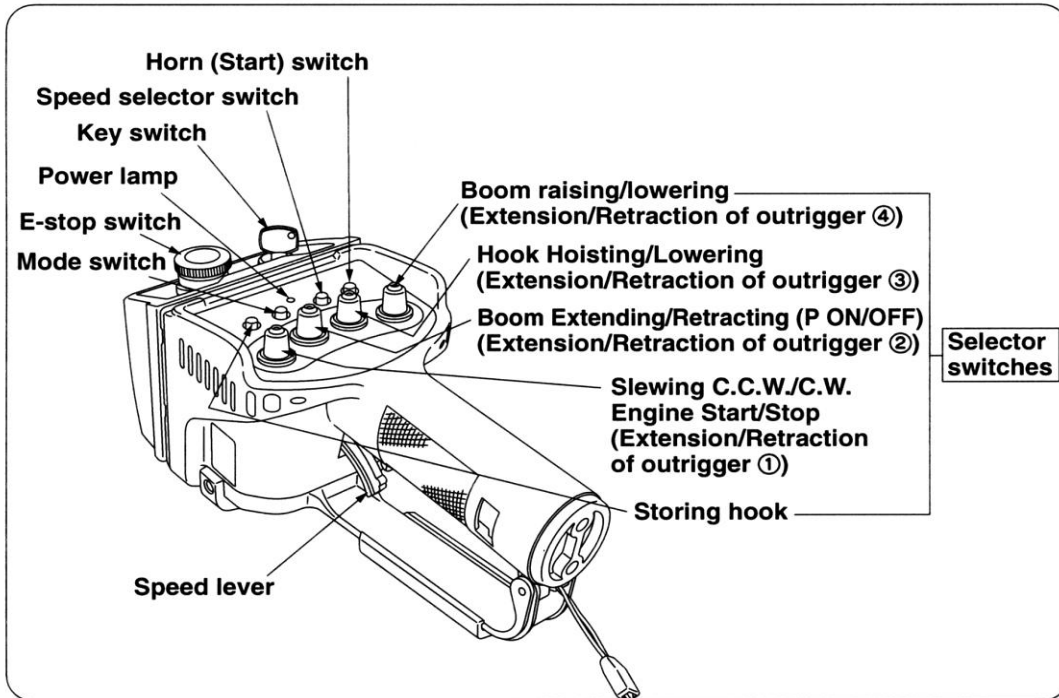

**3. Designation of each part of receiver**

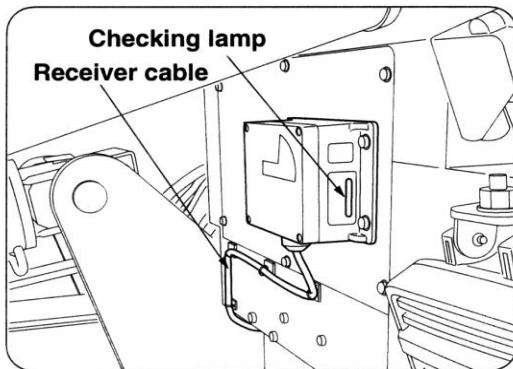

\*Receiving antenna is built in the receiver.



**b. Description of Control Box Parts**

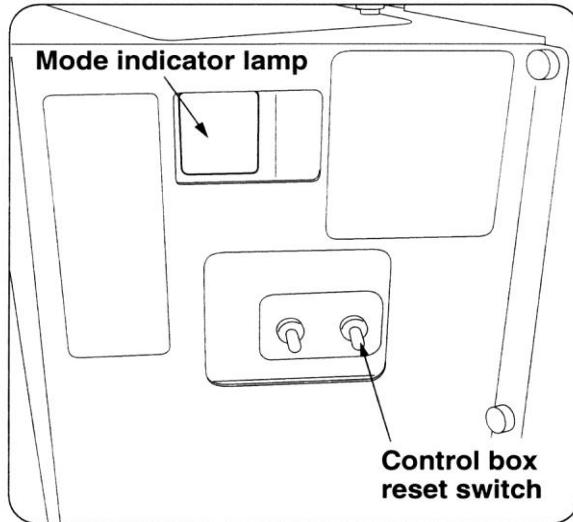

MANUAL/  
RADIO REMOTE

LAMP	POSSIBLE OPERATION
ON	RADIO CONTROL
OFF	MANUAL

The operation mode is changed with the mode selection switch

**MODE SELECTION SWITCH**

UCE.02.62.GB URW376/506

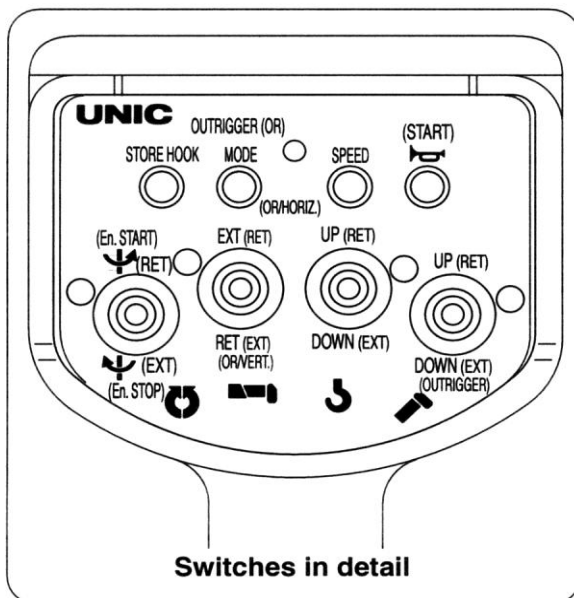



**NB**

**DO NOT carry out any crane functions while system is in self-test. Otherwise the voice warning system will announce:**

**“SERVICE REMOTE CONTROL, SERVICE REMOTE CONTROL“**

**and the system will become inoperable. To correct this press the reset button on the control box on the crane to restart the self-test.**

**NB**

**If the mode indicator does not fully light up (as 8 . 8) or the voice warning system announces:**

**“SERVICE REMOTE CONTROL, SERVICE REMOTE CONTROL“**

**even though no crane functions were carried out, then go to page 150 for fault diagnosis.**

The power to the remote control system is controlled by the engine starter key. When this is turned on the mode indicator lamp in the control box illuminates and the Power light on the remote control handset blinks green.

**a. *Before Operation of the UNIC Radio Remote control***

1. Ensure the Emergency Stop button is reset;
2. Turn the key to the 'ON' position;
3. Press the (Start) button once;
4. The Power light illuminates (in red, orange or green) informing the operator the system is now live. If the Power light blinks or fails to illuminate, change the handset batteries;
5. The (Start) button reverts to being the horn button until the system is shut down;
6. Ensure the VOICE switch is ON.

Power to the handset can be turned off by depressing the emergency stop switch or turning the key to the off position. Power will automatically be turned off after 5 minutes if no functions have been carried out.

**i. Emergency Stop switch check**

Check the emergency stop switch has been reset. The crane will not operate if the emergency stop switch has been depressed. Press the emergency stop switch again to reset.

**ii. Remote Control ON/OFF**

Toggle the remote control selector switch on the control panel of the crane. The mode indicator lamp will illuminate. Toggling the switch again will switch back to manual mode and the mode indicator lamp will extinguish.

In remote control OFF mode the dot at the bottom right of the display will light. No crane functions can be carried out (only the signal horn will operate).

Toggling the remote control selector switch again will turn the remote control on. The dot at the bottom right of the display will turn off, the mode indicator will illuminate and the voice warning system will announce:



**“REMOTE CONTROL READY, REMOTE CONTROL READY**

All crane functions may now be carried out by remote control.

Turning the crane/outrigger mode switch on the cranes control panel to outrigger while the remote control is off, temporarily turns the remote control to on to allow the outriggers to be operated by remote control, **NO OTHER FUNCTIONS CAN BE CARRIED OUT.** Returning the mode switch to crane turns off the remote control.

If the self test is satisfactory, the mode indicator will display one of the following four modes.

Mode	Information	Priority
0 0	Current operation mode is normal radio remote control mode	4
0 F	Current operation mode is travelling mode	1
0 4	Current operation mode is outrigger radio remote control mode	2
1 0	Hook strikes against weight for overwind alarm	3



**DO NOT touch any of the manual levers on the crane when carrying out remote control operations as they will move in conjunction with the remote control instruction and could cause serious injury.**



**NEVER operate the crane at a speed higher than necessary as this could lead to loss of control of the crane, causing possible serious injury and damage to the crane.**

***b. Crane Operations***

Press the desired selector button to carry out the corresponding crane function. Pull the speed lever slowly to begin the crane function. Pull the speed lever further to accelerate the movement.

When stopping the crane function, release the speed lever slowly and when the movement has stopped, allow the selector button to return to off.

***i. Confirm and change speed mode***

To confirm the speed mode check the colour of the power indicator lamps, if it is:

- Red: the crane is in high speed mode;
- Orange: the crane is in medium speed mode;
- Green: the crane is in low speed mode.

If no power indicator lamp is lit press the speed selector switch. In addition the power indicator lamp will light when any switch on the remote control is activated and will remain lit for approximately 3 seconds after the switch/button is returned to neutral.





Orange is achieved by lighting the red and green simultaneously. However, in conditions of bright sunlight the two lights may be seen separately.

To change speed. Depressing the speed selector switch will cycle the speed mode. If the switch is pressed when the red light is on (high speed mode) it will cycle to orange (medium speed mode). Selecting again will cycle to green (low speed mode) and again will cycle it back to red (high speed mode)



**The remote control memorises the last speed mode set before turning off the power. The operator must be aware of this as the crane may operate at a higher speed than the operator is expecting.**



**The speed mode can only be changed through the remote control.**

#### ii. *Interlocking balance control function*

Interlocking is where 2 or more function switches on the remote control are selected at the same time. The system provides a method of balancing the hydraulics to give the optimum performance for each selected functions.

When returning to “independent” function from interlocked function, i.e. releasing all other selected functions to use only one, the selected function may be slower than normal. This is a safety feature, it prevents the sudden, unexpected, acceleration of the function. If you want to return to proper independent function, release all interlocked controls and reselect the desired independent control.

#### iii. *Temporary change of interlock balance (Click function)*

When carrying out “2-interlock” operation (2 selector switches used together), the speed balance of a selected interlocked function can be temporarily adjusted. Simply click the selector switch for the desired function and that function speeds up in relation to the other function. The more times you click the selector, the faster it gets, until you achieve the maximum possible speed. To return the balance to its’ normal speed relationship, release both selection levers and restart the interlocked functions.

**N.B. This does not work in 3-interlock and 4-interlock operations.**

Example of operation

Pull the speed lever with the “hook-winding up/down” switch selected to “winding down” and the “boom telescoping” switch selected to “Extend”.

To increase the boom extension speed, “Click” the boom telescoping switch from Extend to Off and back to Extend again



#### iv. *Reduced Shock Function*

There is a selectable function that reduces the amount of shock loading to the load and the crane. This functions by allowing the crane to come to a slow stop, rather than a sudden stop if any of the function switches are suddenly released.



**BE AWARE that the crane will still make slight movements when the selected function is deselected suddenly. All personnel operating in the vicinity of the crane must be aware of this.**

To de-activate the reduced shock function, select the hook-winding up/down to “Down” while the mode switch is depressed. To re-activate the reduced shock function select the hook-winding up/down switch to “Up” while the mode switch is depressed.

If the mode indicator lamp is showing any of the numerals [00] to [07] and the reduced shock function is de-activated, the left figure of the pair will show as [-], i.e. [-0] to [-7]. When the reduced shock function is activated the left figure of the pair will show as [0], i.e. [00] to [07].



**Check that the indicator changes accordingly when the function is activated or de-activated.**



**When the mode indicator display shows [1 0], overwind condition, this condition must be removed by lowering the hook or retracting the boom, before the reduced shock function can be changed.**



**BE AWARE, the remote control memorises the reduced shock function setting when the power is turned off.**

#### v. *Engine speed control function*

The remote control is equipped with a system to limit the engine speed to a suitable speed for the operating conditions. During independent operation the system limits the engine speed during operation. When interlocked operation is selected, the engine speed does increase, to cope with the increased hydraulic demands, but there is no increase in the selected maximum engine speed. During outrigger operation the engine will always run at medium speed.

d. Hook Operation



**DO NOT** stand near the hook whilst operating any of the levers as the hook may strike you. Always store the hook with the boom fully retracted and lowered.



**DO NOT** operate the hook storage control while operating any other control this will cause a malfunction and possible breakdown.



**DO NOT** try to stow the hook while it is still swinging, this will cause damage to the boom, the wire rope and the hook itself.

Wind up the hook with hook-winding up/down switch selected to “Up”. The hook will automatically stop being wound up when the hook block contacts the overwinding alarm weight. The voice warning system will announce:

**“STOP WINCH UP, STOP WINCH UP”**

When the hook comes to a standstill, select the hook storing switch and the voice warning system will announce:

**“SECURE LIFTING HOOK, SECURE LIFTING HOOK”**

When the speed lever is pulled the hook winds up slowly and the mode indicator lamp shows [13] during this operation. When the hook is stored correctly, return the speed lever and hook storing switch to the neutral position to stop further winding up. If the hook does not appear to be storing correctly, wind down the hook and start again.

e. Outrigger Operations

i. Before Operation

Depress Mode switch and set Boom EXT/RET to EXT. The voice message ‘**Change Control Mode, Change Control Mode**’ is voiced. Control of the outrigger inner box extension/retraction function is now enabled. The outrigger mode light on the top of the crane control panel illuminates and all crane functions are disabled.

The mode indicator lamp will change to [04] or [05]

ii. Operation

Select the “selector switch” which has the number corresponding to the outrigger you want to move. Only two outriggers may be operated at once. Move the selector switch to the direction you want to move the outrigger EXT(end) or RET(ract) and pull the speed lever slowly.

Depress Mode switch and set Boom EXT/RET to RET. The voice message ‘**Change Control Mode, Change Control Mode**’ is voiced. Control of the outrigger vertical cylinder extension/retraction function is now enabled.



Select the “selector switch” which has the number corresponding to the outrigger you want to move. Only two outriggers may be operated at once. Move the selector switch to the direction you want to move the outrigger EXT(end) or RET(ract) and pull the speed lever slowly. When the outrigger touches the ground release the speed lever slowly and return the selector switches to the neutral position.

Repeat for all outriggers

Use two outriggers at a time to raise the crane approximately 50cm from the ground. Select individual or no more than two outriggers to level the crane with the assistance of the bubble level at the drivers position.

To return to crane mode, depress the Mode switch and select Boom Up. The voice message ‘**Change Control Mode, Change Control Mode**’ is heard and the outrigger mode indicator lamp on the crane control panels is extinguished.

**f. Temporarily overriding the automatic wind-up stop**



**This is to be considered as an emergency measure only. DO NOT carry out this operation unless there is no other way to operate the crane to recover from a dangerous condition.**

Move the Overwinding Automatic Stop switch to Reset. Releasing the switch will return it to its default ON position.

**g. Low Temperature Operation**



**The viscosity of the oil becomes high at lower temperatures. This can cause excessive loads to be imposed on the hydraulic pumps which may cause damage.**



**In low temperature always run the engine for 10 minutes to warm the oil and always begin operations in Low Temperature Operation Mode.**

**i. Selecting Low Temperature Operating Mode**

Select the slewing switch to CCW, **then** depress the hook storing switch. It is important that it is carried out in that order.

The mode indicator lamp changes to [0 6] and the voice warning system announces:

**“CHANGE CONTROL MODE, CHANGE CONTROL MODE“**

The mode indicator will not change if it is at [0 4], [0 5] or [1 0]

**ii. Resetting the Low Temperature Operating Mode**

Select the slewing switch to CW, **then** depress the hook storing switch. It is important that it is carried out in that order.



The mode indicator lamp changes to [00] and the voice warning system announces:

**“CHANGE CONTROL MODE, CHANGE CONTROL MODE “**

The mode indicator will not change if it is at [04], [05] or [1 0]

In addition the mode will reset automatically 10 minutes after it was selected and the voice warning system and mode indicator lamp will respond as if it had been manually reset.

***h. Daily Checks***

Basic daily checks should be carried out on the remote control to avoid problems when the remote control is in-use.

- i. Check the exterior of the remote control housing for cracks. These could allow the ingress of moisture or dust which could lead to incorrect operation of the remote control.
- ii. Wipe down the remote control and switches to ensure mud and debris do not get into the remote.
- iii. Carry out a functional check of the function control switches.

If any of the switches fail to operate correctly, or the remote control as a unit fails to operate, check the following and then contact your nearest UNIC service agent.

Check if;

- 1 The crane is operated by the manual levers;
- 2. The “power indicator lamp” on the remote control lights;
- 3. Switches and control levers on the remote control carry out the correct function;
- 4. The mode indicator illuminates correctly to show when the power to the remote control is ON. If the mode indicator blinks, refer to section 8 Mode Indicator.

***i. Emergency Stop***

Where an immediate stop is needed for safety reasons, press any Emergency Stop button, either on the remote controller or crane. This will stop the engine running and halt ALL operations.



**j. Emergency Operation**

If the crane cannot be operated either by remote control or manually then it must be operated as follows:

**Procedure 1:**

- i. Remove the lock pin attached to the emergency screw. Turn the screw clockwise by hand until it has reached the end of its' travel.
- ii. Check all manual control levers are in the neutral position.
- iii. Remove the cover located under the control valve to disconnect the power connector. The crane should now be able to travel. Store the crane using the manual control levers. Contact your nearest authorised UNIC service agent.

**Procedure 2:** If the crane cannot be operated, even by using Procedure 1, carry out the following:

- i. Unfasten the nut attached to the lower part of the control valve to tighten the locked set bolt until it comes to a stop. The crane can now be operated. Store the crane using the manual control levers. Contact your nearest authorised UNIC service agent.





**k. Mode Indicator**

The mode indicator is mounted in the control box and indicates conditions of crane operation and faults.

When the mode indicator displays are steady, the crane is operating normally.

When the mode indicator displays are blinking, there is either a fault or a prohibited operation is being attempted.

Mode	Mode Description	Remote Control Operation	Manual Operation	Priority
0F	Current control is in travelling mode. No operation but travelling is possible either manually or by remote control	X	X	1
00	Current control is in normal crane mode. Operation may be carried out manually or by remote control.	O	O	8
01	Current control is normal crane mode. Operation may be carried out manually but not by remote control.	X	O	8
04 05	Current control is in outrigger mode. Only outrigger functions may be carried out, by either manual or remote control	O	O	4
06	Current control is low temperature operation mode. Operation can be done either manually or by remote control	O	O	7
07	Current control is low temperature operation mode. Operation can only be done manually, not by remote control	X	O	7
10	Hook block has struck the overwind alarm weight	-	-	6
13	Operation for storing hook	-	-	5
14	Automatic stop for overwinding is being overridden	-	-	3
15	ML Stop signal is received or slewing restriction switch is activated.	-	-	2



When the display is blinking numbers after [42] the crane system is faulty. Locate the fault using the mode indicator display table below.

Mode	Mode Description	Remote Control Operation	Manual Operation
42 – 46	No operation is possible with either manual or remote control	X	X
47 – 50	Turn OFF power once, then turn it ON. If the problem persists ask authorised UNIC service agent for repair.	O	O
51 – 53	No operation with remote control is possible	X	O
54	Remote control is not connected, or Check that remote control cable is properly/securely connected, or Check remote control cable for damage.	X	O
55	Either one of the mode selector switches and the hook storing switch on the switch panel, or the remote controller selector switch is faulty. (The failed switch function cannot be operated, but other crane operations are possible)	O	O
56	No operation is possible with remote or manual controls	X	X
57	No operation is possible with remote or manual controls. Turn power OFF and then ON	X	X
58	Operation through remote control becomes impossible, engine speed controller and safety devices fail to function	X	O
59	Emergency Stop switch on switch panel of crane has been activated. If this appears when an Emergency Stop switch has not been activated, contact you nearest authorised UNIC service agent for repair.	O	O
60 – 65	Manual lever is not at neutral position when power is turned ON Do not carry out crane operation during the first 2 seconds as it is carrying system diagnosis If this appears even when no operations are being attempted, contact you nearest authorised UNIC service agent for repair.	X	X
66 – 69	One or more of the outrigger selection switches on the crane switch panel are faulty. The failed switch(es) does not function but other functions may be carried out.	O	O



70 – 74	Stop remote control operation. Try operation by manual control levers. Ensure that a manual lever is not jammed or interfering. If there appears to be no problem, but display fails to return to normal, contact you nearest authorised UNIC service agent for repair.	X	X
75	Engine speed controller has failed. Crane can be operated, contact you nearest authorised UNIC service agent for repair.	O	O
76 – 79	Remote control operation is impossible	X	O
80 – 85	No operation is possible with either remote or manual controls	X	X

When prohibited operations or combinations of operations that may lead to dangerous situations are carried out, the mode indicator will blink numbers corresponding to the error as shown in the table below.

Mode	Error Description	Measures
01	Attempt to operate crane with the remote control in the OFF position When the remote control is OFF the dot in the bottom right hand corner lights.	When in remote control off mode, the crane cannot be operated with the remote controller
04	Attempt to operate crane when in outrigger mode	When in outrigger mode crane cannot be operated.
	Attempt to switch to outrigger mode during crane operation	The mode will not switch to outrigger mode until all crane operations have stopped
	Attempt to operate crane and outriggers simultaneously	<b>ALL</b> operations will stop. Then recommence the operation you want
06	An attempt is being made to switch to low temperature operations mode while carrying out normal crane operations.	To avoid a risk to personnel and the crane, the crane must be completely stopped before this mode can be selected.
10	Hook block has struck the weight for the overwinding alarm	Either wind down hook or retract boom so that the hook block allows the weight to hang free.



***I. Emergency Measures***

Measures to be taken when the crane is not operating correctly, even though the mode indicator is showing correct operation.

<b>Error</b>	<b>Possible Cause</b>	<b>Measures to be taken</b>
Crane fails to operate by using either remote or manual controls	Emergency Stop switch on crane switch panel has been activated.	Check that the Emergency Stop switch is released
Crane operates when a selector switch is activated, but <b>NOT</b> the speed switch	Speed lever of the remote control is faulty	Contact you nearest authorised UNIC service agent for repair.
Crane operates even though no manual or remote controls are being selected	A control solenoid valve is faulty	Stop crane with Emergency Stop switch. Remove lock pin from emergency screw (see page xx) and screw in lightly until it has reached the end of its' travel. Reset the Emergency Stop switch, start the crane and ensure that no operations take place of their own accord. Store crane and contact you nearest authorised UNIC service agent for repair.

### Changing Radio Remote Handset Batteries



When indicated, change batteries as soon as possible. Leaving the batteries in the handset may cause the batteries to leak. This may damage the electrical contacts and housing. If the batteries do leak, wipe the battery compartment thoroughly before inserting new batteries.



The use of alkaline batteries is recommended. If rechargeable batteries (NiCd or NiMH) are used beware of the following:

Messages suggesting replacement of battery might not be issued.

Batteries may become drained suddenly

Full charge may not be achieved with NiCd batteries due to memory effect

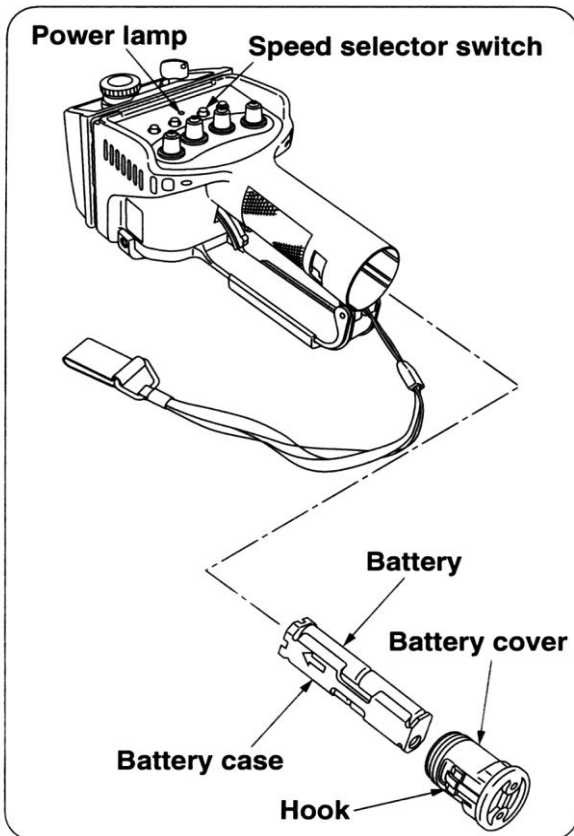

With the speed selector switch depressed, observe the power lamp.

If the lamp is lit continuously the batteries are in good condition.

Flashing every second, batteries must be changed as soon as possible. The voice message '**LOW TRANSMITTER BATTERY, LOW TRANSMITTER BATTERY**' will be voiced. The Error lamp on the receiver will flash and the code **99** will appear in the mode indicator window.

Flashing every 0.1 seconds or not lit at all, change batteries immediately they are completely exhausted.

To replace the batteries:

- Turn OFF the crane starter switch
- Push in the hook on the base of the battery cover and pull off the cover
- Replace the old batteries with 4 new type AAA batteries
- Replace the battery holder in the transmitter grip and tighten it.
- Depress the speed selector switch to check the power light

a. Safe load indicator manual

**W3000 DISPLAY BUTTON PRESENTATION**

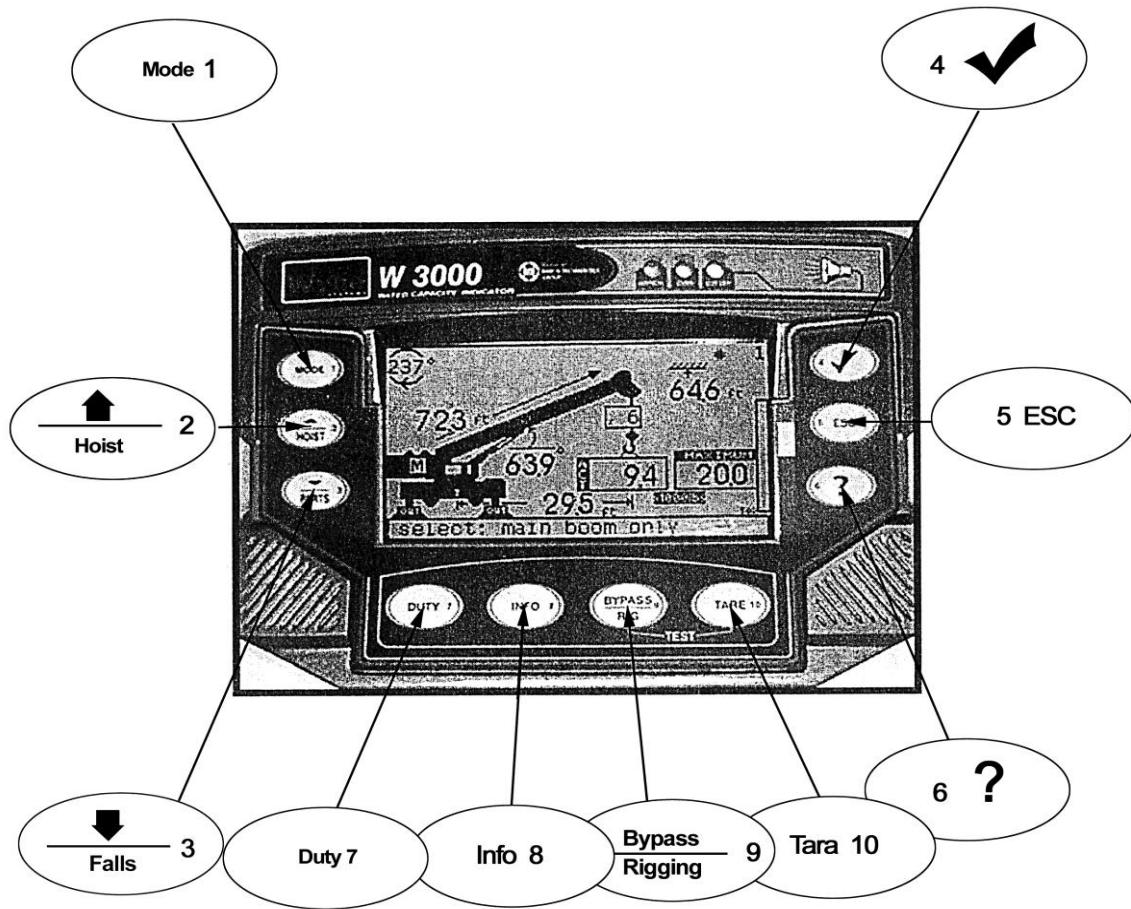





### W3000 DISPLAY BUTTON PRESENTATION

- Mode 1

**MODE:** Shows system's modes
- 

---

Hoist

2

**HOIST/SCROLL UP:** Shows hoists for selection. Also used to scroll up in menus and increase editable values
- 

---

Falls

3

**PARTS/SCROLL DOWN:** Shows parts of line (falls). Also used to scroll down in menus and decrease modifiable values.
- 4



**SELECT:** Used to select a highlighted item in the menu. In normal mode use this button to change the information displayed in the state display
- 5

ESC

**ESCAPE:** Used to close a menu or cancel the modification of a value. Push it several times to return to normal mode.
- 6

?

**HELP:** This button will only work when a fault is detected by the system. Push it to see a description of the problem.
- Duty

**DUTY:** Show the menu for the selection of the duty by number or by crane configuration.
- Info

**INFO:** Show all the information regarding the current configuration. Push it a second time to access the operating system's information.
- Bypass

---

Rigging

9

**BYPASS/RIGGING:** Push this button to bypass the system's lockout. Also used to enter the rigging mode. Neither of these functions are used on this model of crane
- Tare

**TARE:** Switch the load display between the actual load and the tare load

