



Palift
PALAZZANI

RAGNO XTJ 32



32 m ↑
14,5 m →
330 Kg 🧑🧑🧑

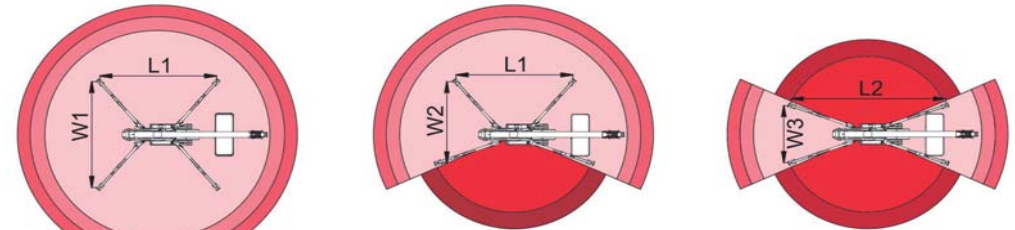
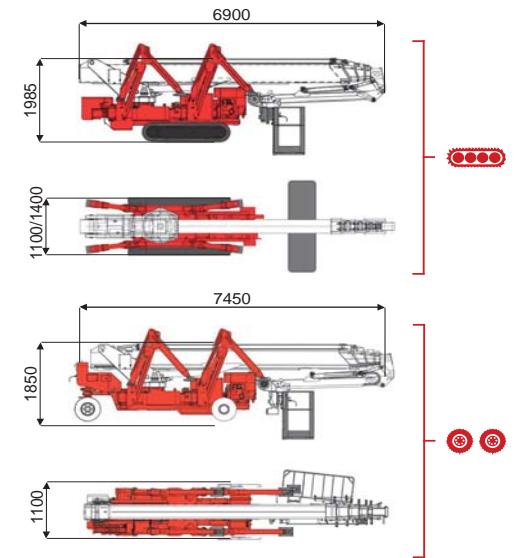
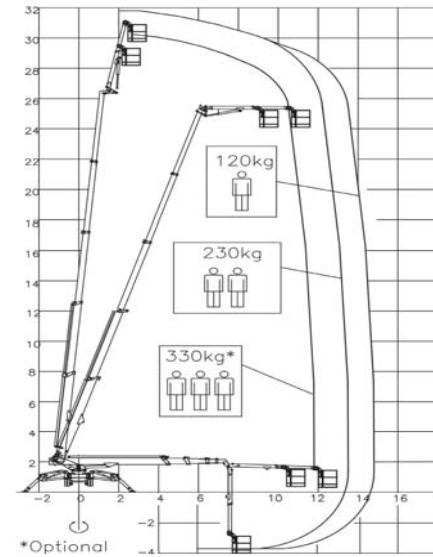

12000 mm	13500 mm	14500 mm	7400 mm	10500 mm	L1	L2	W1	W2	W3
330 kg	250 kg	120 kg	330 kg	120/230 kg	5113 mm	6445 mm	4743 mm	3781 mm	2823 mm

BI-ENERGY
Diesel+AC



XTJ 32/C	🔋🔋🔋	32 m	14,5 m	330 kg	175°	540°	180x70 cm	90°+80°	2,8-4,7 m	15%	40%	3,0 km/h	5940 kg	35 kN	2,62 kN/m ²	4,53 kN/m ²	1100/1400 mm	6900 mm	1985 mm
XTJ 32/R	⊙ ⊙	32 m	14,5 m	330 kg	175°	540°	180x70 cm	90°+80°	2,8-4,7 m	15%	40%	2,5 km/h	5940 kg	35 kN	2,62 kN/m ²	4,53 kN/m ²	1100 mm	7450 mm	1850 mm

		Battery type	Battery charge	Add. Weight	Autonomy	Charging time	Electropump	
ECO	DC+AC	🔋🔋🔋 ⊙ ⊙	48V 320 A/h	230V-48V 45A	450 kg	6-7 h endless	7h	48V 12 kW
HYBRID	Diesel+DC	🔋🔋🔋 ⊙ ⊙	24V 240 A/h	230V-24V 35A	200 kg	2-3 h endless	7h	24V 5,5 kW

Palazzani
INDUSTRIE

Palazzani Industrie S.p.A.
Via del Pavione, 4
25050 - Paderno F.C. (BS) - Italy
Tel. (+39) 0306857073 Fax (+39) 030657079
platforms@palazzani.it
www.palazzani.it

COMPANY WITH
QUALITY SYSTEM
CERTIFIED BY DNV GL
= ISO 9001 =