

Self-Propelled Articulating Booms

Z™-33/18

Specifications

Model Z-33/18

Measurements	Metric
Working height maximum*	12 m
Platform height maximum	10 m
Horizontal reach maximum	5.57 m
Up and over clearance maximum	4.28 m
A Platform length	0.76 m
B Platform width	1.17 m
C Height - stowed	1.98 m
D Length - stowed	4.17 m
E Width	1.50 m
A Wheelbase	1.90 m
A Ground clearance - center	15.2 cm

Productivity

Lift capacity	200 kg
Turntable rotation	
Turntable tailswing at counterweight	zero
Turntable tailswing - riser up	0.15 m
Turntable tailswing - riser down	1.16 m
Drive speed - stowed	5.2 km/h
Drive speed - raised retracted**	0.87 km/h
Drive speed - raised extended**	0.23 km/h
Gradeability - stowed***	
Turning radius - inside	1.9 m
Controls	
Tires (solid rubber, non-marking, treaded)	56x23x43 cm

Power

Power source	48 V DC (eight 6 V X 8 batteries 350 Ah capacity)
Drive system	AC Drive, 48V 3 phase
Auxiliary power unit	24 V DC
Hydraulic tank capacity	20.8 L

Weight****

3,665 kg

Standards Compliance

ANSI A92.5, CSA B354.4, EN 280, AS 1418.10

Range Of Motion Z-33/18

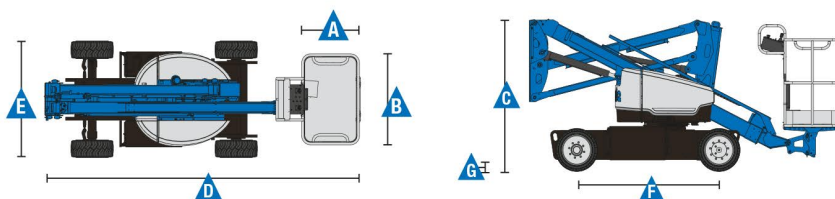
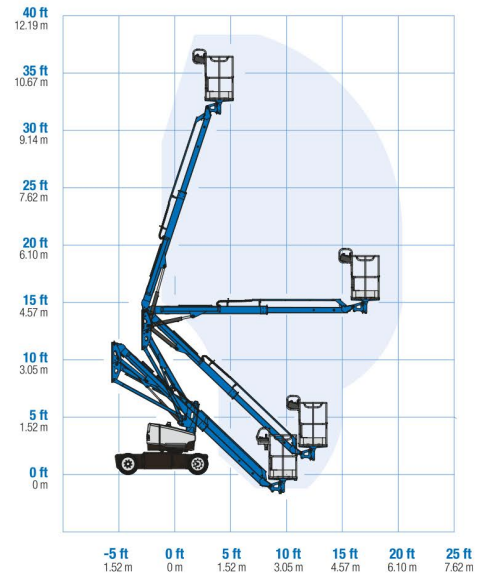

* The metric equivalent of working height adds 2 m to platform height. U.S. adds 6 ft to platform height.
 ** In lift mode (platform raised), the machine is designed to operate on firm, level surfaces only.
 *** Gradeability applies to driving on slopes. See operator's manual for details regarding slope ratings.
 **** Weight will vary depending on options and/or country standards.